

NARASARAOPETA ENGINEERING COLLEGE

(Autonomous)

Narasaraopet-522601

DEPARTMENT OF ELECTRICAL AND ELECTRONICS ENGINEERING

VII Semester

Course Title : Power System Operation and Control

Syllabus

UNIT - I

ECONOMIC OPERATION OF POWER SYSTEMS: Optimal operation of Generators in Thermal Power Stations, - heat rate Curve – Cost Curve – Incremental fuel and Production costs, input-output characteristics, Optimum generation allocation with line losses neglected. Optimum generation allocation including the effect of transmission line losses – Loss Coefficients, General transmission line loss formula.

UNIT - II

HYDROTHERMAL SCHEDULING: Optimal scheduling of Hydrothermal System: Hydroelectric power plant models, Scheduling problems-Short term hydrothermal scheduling problem.

UNIT - III

MODELLING OF TURBINE, GENERATOR AND AUTOMATIC CONTROLLERS: Modeling of Turbine: First order Turbine model, Block Diagram representation of Steam Turbines and Approximate Linear Models. Modeling of Generator (Steady State and Transient Models): Description of Simplified Network Model of a Synchronous Machine (Classical Model), Description of Swing Equation (No Derivation) and State-Space II-Order Mathematical Model of Synchronous Machine.

MODELLING OF GOVERNOR: Mathematical Modeling of Speed Governing System – Derivation of small signal transfer function.

MODELLING OF EXCITATION SYSTEM: Fundamental Characteristics of an Excitation system, Transfer function, Block Diagram Representation of IEEE Type-1 Model

UNIT - IV

LOAD FREQUENCY CONTROL: Necessity of keeping frequency constant. Definitions of Control area – Single area control – Block diagram representation of an isolated power system – Steady state analysis – Dynamic response – Uncontrolled case. Load frequency control of 2-area system – uncontrolled case and controlled case, tie-line bias control

LOAD FREQUENCY CONTROLLERS: Proportional plus Integral control of single area and its block diagram representation, steady state response – Load Frequency Control and Economic dispatch control.

UNIT - V

REACTIVE POWER CONTROL: Overview of Reactive Power control – Reactive Power compensation in transmission systems – advantages and disadvantages of different types of compensating equipment for transmission systems; load compensation – Specifications of load compensator, Uncompensated and compensated transmission lines: shunt and Series Compensation.- Deregulation.

TEXT BOOKS:

1. I.J.Nagrath & D.P.Kothari (2006), *Modern Power System Analysis*, 3rd Edition, McGraw Hill higher Education, New Delhi.
2. P.S.R.Murthy (2008), *Power System operation and Control*, 1st Edition, Tata McGraw Hill Publishers, New Delhi.

REFERENCE BOOKS:

1. Hadi Saadat (2010), *Power System Analysis*, Revised Edition, PSA Publishers, New Delhi.
2. O.I.Elgerd (2007), *Electric Energy systems Theory*, 2nd Edition, Tata McGraw hill Publications, New Delhi.

UNIT-I

Economic Operation of Power Systems -1

Overview

- Economic Distribution of Loads between the Units of a Plant
- Generating Limits
- Economic Sharing of Loads between Different Plants

Automatic Generation Control

- Load Frequency Control

Coordination between LFC and Economic Dispatch

A good business practice is the one in which the production cost is minimized without sacrificing the quality. This is not any different in the power sector as well. The main aim here is to reduce the production cost while maintaining the voltage magnitudes at each bus. In this chapter we shall discuss the economic operation strategy along with the turbine-governor control that are required to maintain the power dispatch economically.

A power plant has to cater to load conditions all throughout the day, come summer or winter. It is therefore illogical to assume that the same level of power must be generated at all time. The power generation must vary according to the load pattern, which may in turn vary with season. Therefore the economic operation must take into account the load condition at all times. Moreover once the economic generation condition has been calculated, the turbine-governor must be controlled in such a way that this generation condition is maintained. In this chapter we shall discuss these two aspects.

Economic operation of power

systems Introduction:

One of the earliest applications of on-line centralized control was to provide a central facility, to operate economically, several generating plants supplying the loads of the system. Modern integrated systems have different types of generating plants, such as coal fired thermal plants, hydel plants, nuclear plants, oil and natural gas units etc. The capital investment, operation and maintenance costs are different for different types of plants.

The operation economics can again be subdivided into two parts.

- Problem of *economic dispatch*, which deals with determining the power output of each plant to meet the specified load, such that the overall fuel cost is minimized.
- Problem of *optimal power flow*, which deals with minimum – loss delivery, where in the power flow, is optimized to minimize losses in the system.

In this chapter we consider the problem of economic dispatch. During operation of the plant, a generator may be in one of the following states:

- i) Base supply without regulation: the output is a constant.
- ii) Base supply with regulation: output power is regulated based on system load.
- iii) Automatic non-economic regulation: output level changes around a base setting as area control error changes.
- iv) Automatic economic regulation: output level is adjusted, with the area load and area control error, while tracking an economic setting. Regardless of the units operating state, it has a contribution to the economic operation, even though its output is changed for different reasons.

The factors influencing the cost of generation are the generator efficiency, fuel cost and transmission losses. The most efficient generator may not give minimum cost, since it may be located in a place where fuel cost is high. Further, if the plant is located far from the load centers, transmission losses may be high and running the plant may become uneconomical. The economic dispatch problem basically determines the generation of different plants to minimize total operating cost.

Modern generating plants like nuclear plants, geo-thermal plants etc, may require capital investment of millions of rupees. The economic dispatch is however determined in terms of fuel cost per unit power generated and does not include capital investment, maintenance, depreciation, start-up and shut down costs etc.

Performance Curves Input-Output Curve

This is the fundamental curve for a thermal plant and is a plot of the input in British

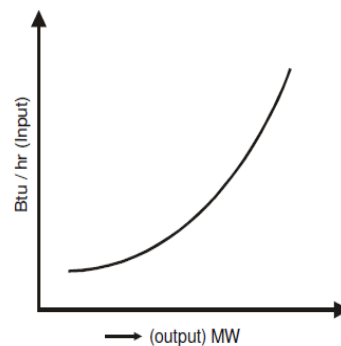

Fig 1: Input – output curve

Thermal units (Btu) per hour versus the power output of the plant in MW as shown in Fig1

Incremental Fuel Rate Curve

The incremental fuel rate is equal to a small change in input divided by the corresponding change in output.

$$\text{Incremental fuel rate} = \frac{\Delta \text{Input}}{\Delta \text{Output}}$$

The unit is again Btu / KWh. A plot of incremental fuel rate versus the output is shown in Fig 3

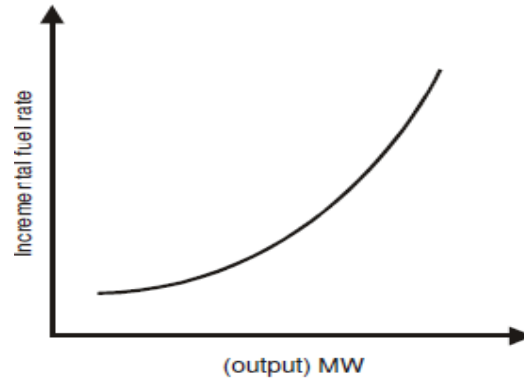

Fig 3: Incremental fuel rate curve

Incremental cost curve

The incremental cost is the product of incremental fuel rate and fuel cost (Rs / Btu) the curve is shown in Fig. 4. The unit of the incremental fuel cost is Rs / MWhr.

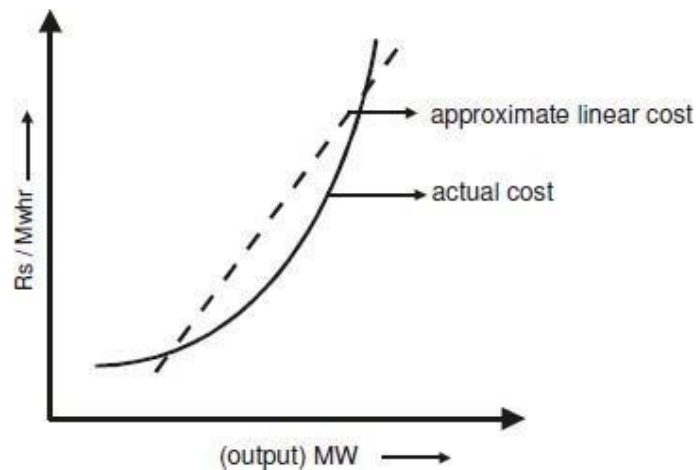

Fig 4: Incremental cost curve

In general, the fuel cost F_i for a plant, is approximated as a quadratic function of the generated output P_{Gi} .

$$F_i = a_i + b_i P_{Gi} + c_i P_{Gi}^2 \quad \text{Rs / h}$$

The incremental fuel cost is given by

$$\frac{dF_i}{dP_{Gi}} = b_i + 2c_i P_{Gi} \quad \text{Rs / MWh}$$

The incremental fuel cost is a measure of how costly it will be produce an increment of power. The incremental production cost, is made up of incremental fuel cost plus the incremental cost of labor, water, maintenance etc. which can be taken to be some percentage of the incremental fuel cost, instead of resorting to a rigorous mathematical model. The cost curve can be approximated by a linear curve. While there is negligible operating cost for a hydel plant, there is a limitation on the power output possible. In any plant, all units normally operate between P_{Gmin} , the minimum loading limit, below which it is technically infeasible to operate a unit and P_{Gmax} , which is the maximum output limit.

Section I: Economic Operation of Power System

- **Economic Distribution of Loads between the Units of a Plant**
- **Generating Limits**
- **Economic Sharing of Loads between Different Plants**

In an early attempt at economic operation it was decided to supply power from the most efficient plant at light load conditions. As the load increased, the power was supplied by this most efficient plant till the point of maximum efficiency of this plant was reached. With further increase in load, the next most efficient plant would supply power till its maximum efficiency is reached. In this way the power would be supplied by the most efficient to the least efficient plant to reach the peak demand. Unfortunately however, this method failed to minimize the total cost of electricity generation. We must therefore search for alternative method which takes into account the total cost generation of all the units of a plant that is supplying a load.

Economic Distribution of Loads between the Units of a Plant

To determine the economic distribution of a load amongst the different units of a plant, the variable operating costs of each unit must be expressed in terms of its power output. The fuel cost is the main cost in a thermal or nuclear unit. Then the fuel cost must be expressed in terms of the power output. Other costs, such as the operation and maintenance costs, can also be expressed in terms of the power output. Fixed costs, such as the capital cost, depreciation etc., are not included in the fuel cost.

The fuel requirement of each generator is given in terms of the Rupees/hour. Let us define the input cost of an unit- i , f_i in Rs/h and the power output of the unit as P_i . Then the input cost can be expressed in terms of the power output as

$$f_i = \frac{a_i}{2} P_i^2 + b_i P_i + c_i \quad \text{Rs/h} \quad (1.1)$$

The operating cost given by the above quadratic equation is obtained by approximating the power in MW versus the cost in Rupees curve. The incremental operating cost of each unit is then computed as

$$\lambda_i = \frac{df_i}{dP_i} = a_i P_i + b_i \quad \text{Rs/MWhr} \quad (1.2)$$

Let us now assume that only two units having different incremental costs supply a load. There will be a reduction in cost if some amount of load is transferred from the unit with higher incremental cost to the unit with lower incremental cost. In this fashion, the load is transferred from the less efficient unit to the more efficient unit thereby reducing the total operation cost. The load transfer will continue till the incremental costs of both the units are same. This will be optimum point of operation for both the units. The above principle can be extended to plants with a total of N number of units. The total fuel cost will then be the summation of the individual

fuel cost f_i , $i = 1, \dots, N$ of each unit, i.e.,

$$f_T = f_1 + f_2 + \dots + f_N = \sum_{k=1}^N f_k \quad (1.3)$$

Let us denote that the total power that the plant is required to supply by P_T , such that

$$P_T = P_1 + P_2 + \dots + P_N = \sum_{k=1}^N P_k \quad (1.4)$$

Where P_1, \dots, P_N are the power supplied by the N different units.

The objective is minimizing f_T for a given P_T . This can be achieved when the total difference df_T becomes zero, i.e.

$$df_T = \frac{\partial f_T}{\partial P_1} dP_1 + \frac{\partial f_T}{\partial P_2} dP_2 + \dots + \frac{\partial f_T}{\partial P_N} dP_N = 0 \quad (1.5)$$

Now since the power supplied is assumed to be constant we have

$$dP_T = dP_1 + dP_2 + \dots + dP_N = 0 \quad (1.6)$$

Multiplying (1.6) by λ and subtracting from (1.5) we get

$$\left(\frac{\partial f_T}{\partial P_1} - \lambda \right) dP_1 + \left(\frac{\partial f_T}{\partial P_2} - \lambda \right) dP_2 + \dots + \left(\frac{\partial f_T}{\partial P_N} - \lambda \right) dP_N = 0 \quad (1.7)$$

The equality in (5.7) is satisfied when each individual term given in brackets is zero. This gives us

$$\frac{\partial f_T}{\partial P_i} - \lambda = 0, \quad i = 1, \dots, N \quad (1.8)$$

Also the partial derivative becomes a full derivative since only the term f_i of f_T varies with P_i , $i = 1 \dots N$.

We then have

$$\lambda = \frac{df_1}{dP_1} = \frac{df_2}{dP_2} = \dots = \frac{df_N}{dP_N} \quad (1.9)$$

Generating Limits

It is not always necessary that all the units of a plant are available to share a load. Some of the units may be taken off due to scheduled maintenance. Also it is not necessary that the less efficient units are switched off during off peak hours. There is a certain amount of shut down and start up costs associated with shutting down a unit during the off peak hours and servicing it back on-line during the peak hours. To complicate the problem further, it may take about eight hours or more to restore the boiler of a unit and synchronizing the unit with the bus. To meet the sudden change in the power demand, it may therefore be necessary to keep more units than it necessary to meet the load demand during that time. This safety margin in generation is called spinning reserve.

The optimal load dispatch problem must then incorporate this startup and shut down cost for without endangering the system security.

The power generation limit of each unit is then given by the inequality constraints

$$P_{\min,i} \leq P_i \leq P_{\max,i}, \quad i = 1, \dots, N \quad (1.10)$$

The maximum limit P_{Gmax} is the upper limit of power generation capacity of each unit. On the other hand, the lower limit P_{Gmin} pertains to the thermal consideration of operating a boiler in a thermal or nuclear generating station. An operational unit must produce a minimum amount of power such that the boiler thermal components are stabilized at the minimum design operating temperature.

Example 1

Consider two units of a plant that have fuel costs of

$$f_1 = \frac{0.8}{2} P_1^2 + 10P_1 + 25 \quad \text{Rs/h} \quad \text{and} \quad f_2 = \frac{0.7}{2} P_2^2 + 6P_2 + 20 \quad \text{Rs/h}$$

Then the incremental costs will be

$$\lambda_1 = \frac{df_1}{dP_1} = 0.8P_1 + 10 \quad \text{Rs/MWhr} \quad \text{and} \quad \lambda_2 = \frac{df_2}{dP_2} = 0.7P_2 + 6 \quad \text{Rs/MWhr}$$

If these two units together supply a total of 220 MW, then $P_1 = 100$ MW and $P_2 = 120$ MW will result in an incremental cost of

$$\lambda_1 = 80 + 10 = 90 \text{ Rs/MWhr} \quad \text{and} \quad \lambda_2 = 84 + 6 = 90 \text{ Rs/MWhr}$$

This implies that the incremental costs of both the units will be same, i.e., the cost of one extra MW of generation will be Rs. 90/MWhr. Then we have

$$f_1 = \frac{0.8}{2} 100^2 + 10 \times 100 + 25 = 5025 \text{ Rs/h} \quad \text{and} \quad f_2 = \frac{0.7}{2} 120^2 + 6 \times 120 + 20 = 5780 \text{ Rs/h}$$

And total cost of generation is p

$$f_T = f_1 + f_2 = 10,805 \text{ Rs/h}$$

Now assume that we operate instead with $P_1 = 90$ MW and $P_2 = 130$ MW. Then the individual cost of each unit will be

$$f_1 = \frac{0.8}{2} 90^2 + 10 \times 90 + 25 = 4,165 \text{ Rs/h} \quad \text{and} \quad f_2 = \frac{0.7}{2} 130^2 + 6 \times 130 + 20 = 6,175 \text{ Rs/h}$$

And total cost of generation is

$$f_T = f_1 + f_2 = 10,880 \text{ Rs./h}$$

This implies that an additional cost of Rs. 75 is incurred for each hour of operation with this non-optimal setting. Similarly it can be shown that the load is shared equally by the two units, i.e. $P_1 = P_2 = 110$ MW, then the total cost is again 10,880 Rs/h.

Example 2

Let us consider a generating station that contains a total number of three generating units. The fuel costs of these units are given by

$$f_1 = \frac{0.8}{2} P_1^2 + 10P_1 + 25 \text{ Rs/h}$$

$$f_2 = \frac{0.7}{2} P_2^2 + 5P_2 + 20 \text{ Rs/h}$$

$$f_3 = \frac{0.95}{2} P_3^2 + 15P_3 + 35 \text{ Rs/h}$$

The generation limits of the units are

$$30 \text{ MW} \leq P_1 \leq 500 \text{ MW}$$

$$30 \text{ MW} \leq P_2 \leq 500 \text{ MW}$$

$$30 \text{ MW} \leq P_3 \leq 250 \text{ MW}$$

The total load that these units supply varies between 90 MW and 1250 MW. Assuming that all the three units are operational all the time, we have to compute the economic operating settings as the load changes.

The incremental costs of these units are

$$\frac{df_1}{dP_1} = 0.8P_1 + 10 \quad \text{Rs/MWhr}$$

$$\frac{df_2}{dP_2} = 0.7P_2 + 5 \quad \text{Rs/MWhr}$$

$$\frac{df_3}{dP_3} = 0.95P_3 + 15 \quad \text{Rs/MWhr}$$

At the minimum load the incremental cost of the units are

$$\frac{df_1}{dP_1} = \frac{0.8}{2}30^2 + 10 = 34 \quad \text{Rs/MWhr}$$

$$\frac{df_2}{dP_2} = \frac{0.7}{2}30^2 + 5 = 26 \quad \text{Rs/MWhr}$$

$$\frac{df_3}{dP_3} = \frac{0.95}{2}30^2 + 15 = 43.5 \quad \text{Rs/MWhr}$$

Since units 1 and 3 have higher incremental cost, they must therefore operate at 30 MW each. The incremental cost during this time will be due to unit-2 and will be equal to 26 Rs/MWhr. With the generation of units 1 and 3 remaining constant, the generation of unit-2 is increased till its incremental cost is equal to that of unit-1, i.e., 34 Rs/MWhr. This is achieved when P_2 is equal to 41.4286 MW, at a total power of 101.4286 MW.

An increase in the total load beyond 101.4286 MW is shared between units 1 and 2, till their incremental costs are equal to that of unit-3, i.e., 43.5 Rs/MWhr. This point is reached when $P_1 = 41.875$ MW and $P_2 = 55$ MW. The total load that can be supplied at that point is equal to 126.875. From this point onwards the load is shared between the three units in such a way that the incremental costs of all the units are same. For example for a total load of 200 MW, from (5.4) and (5.9) we have

$$P_1 + P_2 + P_3 = 200$$

$$0.8P_1 + 10 = 0.7P_2 + 5$$

$$0.7P_2 + 5 = 0.95P_3 + 15$$

Solving the above three equations we get $P_1 = 66.37$ MW, $P_2 = 80$ MW and $P_3 = 50.63$ MW and an incremental cost (λ) of 63.1 Rs./MWhr. In a similar way the economic dispatch for various other load settings are computed. The load distribution and the incremental costs are listed in Table 5.1 for various total power conditions.

At a total load of 906.6964, unit-3 reaches its maximum load of 250 MW. From this point onwards then, the generation of this unit is kept fixed and the economic dispatch problem involves the other two units. For example for a total load of 1000 MW, we get the following two equations from (1.4) and (1.9)

$$P_1 + P_2 = 1000 - 250$$

$$0.8P_1 + 10 = 0.7P_2 + 5$$

Solving which we get $P_1 = 346.67$ MW and $P_2 = 403.33$ MW and an incremental cost of 287.33 Rs/MWhr.

Furthermore, unit-2 reaches its peak output at a total load of 1181.25. Therefore any further increase in the total load must be supplied by unit-1 and the incremental cost will only be borne by this unit. The power distribution curve is shown in Fig. 5.

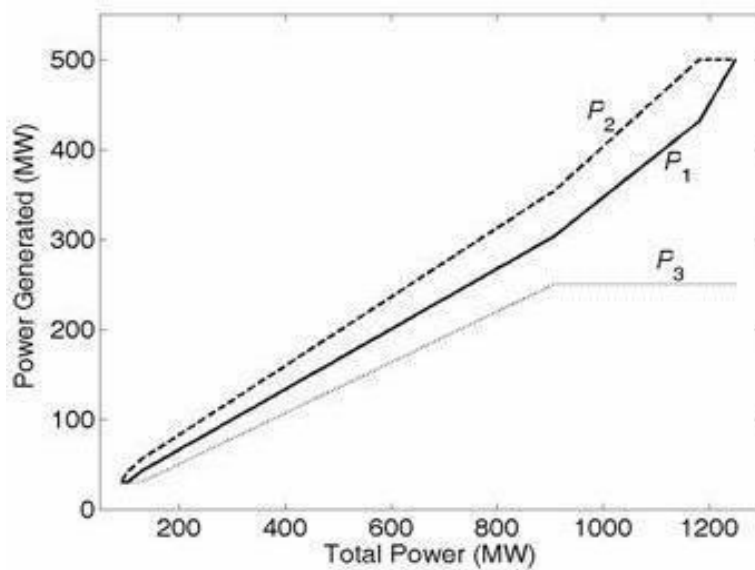

Fig5. Power distribution between the units of Example 2

Example 3

Consider two generating plant with same fuel cost and generation limits. These are given by

$$f_i = \frac{0.8}{2} P_i^2 + 10P_i + 25 \text{ Rs./h} \quad i = 1,2$$

$$100 \text{ MW} \leq P_i \leq 500 \text{ MW}, \quad i = 1,2$$

For a particular time of a year, the total load in a day varies as shown in Fig. 5.2. Also an additional cost of Rs. 5,000 is incurred by switching of a unit during the off peak hours and switching it back on during the during the peak hours. We have to determine whether it is economical to have both units operational all the time.

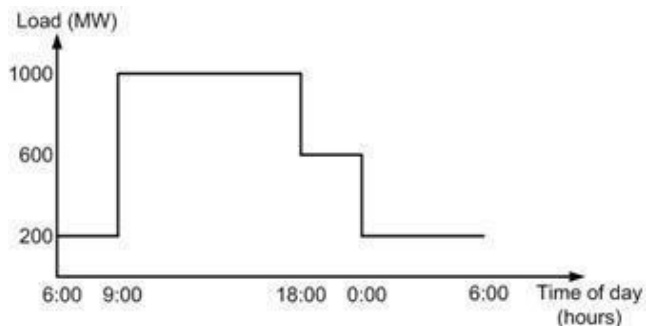

Fig.6. Hourly distribution of a load for the units of Example 2

Since both the units have identical fuel costs, we can switch of any one of the two units during the off peak hour. Therefore the cost of running one unit from midnight to 9 in the morning while delivering 200 MW is

$$\left(\frac{0.8}{2} 200^2 + 10 \times 200 + 25 \right) \times 9 = 162,225 \text{ Rs.}$$

Adding the cost of Rs. 5,000 for decommissioning and commissioning the other unit after nine hours, the total cost becomes Rs. 167,225. 0

On the other hand, if both the units operate all through the off peak hours sharing power equally, then we get a total cost of

$$\left(\frac{0.8}{2} 100^2 + 10 \times 100 + 25 \right) \times 9 \times 2 = 90,450 \text{ Rs.}$$

Which is significantly less that the cost of running one unit alone?

Table 1.1 Load distribution and incremental cost for the units of Example 1

| P_T (MW) | P_1 (MW) | P_2 (MW) | P_3 (MW) | λ (Rs./MWh) |
|------------|------------|------------|------------|---------------------|
| 90 | 30 | 30 | 30 | 26 |
| 101.4286 | 30 | 41.4286 | 30 | 34 |
| 120 | 38.67 | 51.33 | 30 | 40.93 |
| 126.875 | 41.875 | 55 | 30 | 43.5 |
| 150 | 49.62 | 63.85 | 36.53 | 49.7 |
| 200 | 66.37 | 83 | 50.63 | 63.1 |
| 300 | 99.87 | 121.28 | 78.85 | 89.9 |
| 400 | 133.38 | 159.57 | 107.05 | 116.7 |
| 500 | 166.88 | 197.86 | 135.26 | 143.5 |

| | | | | |
|----------|---------|----------|--------|--------|
| 600 | 200.38 | 236.15 | 163.47 | 170.3 |
| 700 | 233.88 | 274.43 | 191.69 | 197.1 |
| 800 | 267.38 | 312.72 | 219.9 | 223.9 |
| 906.6964 | 303.125 | 353.5714 | 250 | 252.5 |
| 1000 | 346.67 | 403.33 | 250 | 287.33 |
| 1100 | 393.33 | 456.67 | 250 | 324.67 |
| 1181.25 | 431.25 | 500 | 250 | 355 |
| 1200 | 450 | 500 | 250 | 370 |
| 1250 | 500 | 500 | 250 | 410 |

DERIVATION OF TRANSMISSION LOSS FORMULA:

An accurate method of obtaining general loss coefficients has been presented by Kroc. The method is elaborate and a simpler approach is possible by making the following assumptions:

- (i) All load currents have same phase angle with respect to a common reference
- (ii) The ratio X / R is the same for all the network branches

Consider the simple case of two generating plants connected to an arbitrary number of loads through a transmission network as shown in Fig a

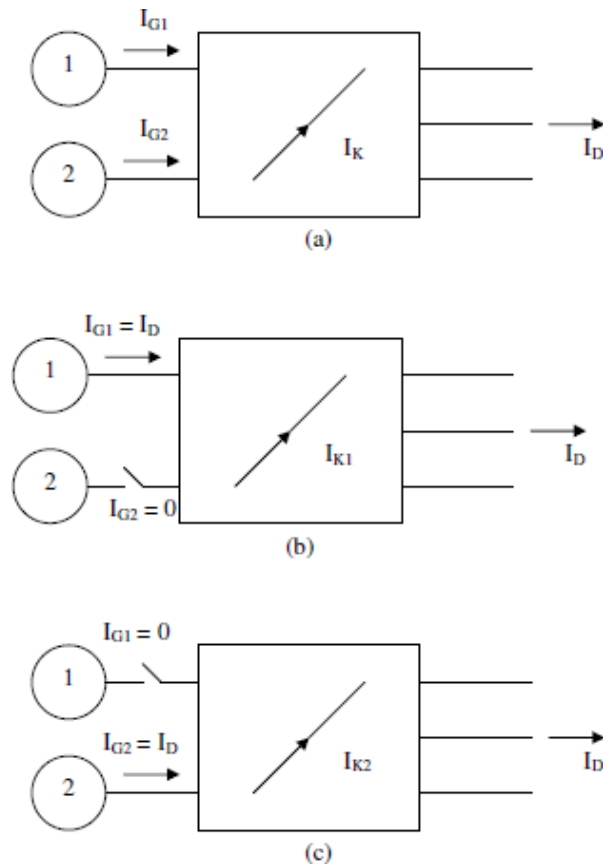

Fig.2.1 Two plants connected to a number of loads through a transmission network

Let's assume that the total load is supplied by only generator 1 as shown in Fig 8.9b. Let the current through a branch K in the network be I_{K1} . We define

$$N_{K1} = \frac{I_{K1}}{I_D}$$

It is to be noted that $I_{G1} = I_D$ in this case. Similarly with only plant 2 supplying the load

current I_D , as shown in Fig 8.9c, we define

$$N_{K2} = \frac{I_{K2}}{I_D}$$

N_{K1} and N_{K2} are called current distribution factors and their values depend on the impedances of the lines and the network connection. They are independent of I_D . When both generators are supplying the load, then by principle of superposition $I_K = N_{K1} I_{G1} + N_{K2} I_{G2}$

Where I_{G1} , I_{G2} are the currents supplied by plants 1 and 2 respectively, to meet the demand I_D . Because of the assumptions made, I_{K1} and I_D have same phase angle, as do I_{K2} and I_D . Therefore, the current distribution factors are real rather than complex. Let

$$I_{G1} = |I_{G1}| \angle \sigma_1 \text{ and } I_{G2} = |I_{G2}| \angle \sigma_2.$$

Where σ_1 and σ_2 are phase angles of I_{G1} and I_{G2} with respect to a common reference. We can write

$$\begin{aligned} |I_K|^2 &= (N_{K1}|I_{G1}| \cos \sigma_1 + N_{K2}|I_{G2}| \cos \sigma_2)^2 + (N_{K1}|I_{G1}| \sin \sigma_1 + N_{K2}|I_{G2}| \sin \sigma_2)^2 \\ &= N_{K1}^2 |I_{G1}|^2 [\cos^2 \sigma_1 + \sin^2 \sigma_1] + N_{K2}^2 |I_{G2}|^2 [\cos^2 \sigma_2 + \sin^2 \sigma_2] \\ &\quad + 2[N_{K1}|I_{G1}| \cos \sigma_1 N_{K2}|I_{G2}| \cos \sigma_2 + N_{K1}|I_{G1}| \sin \sigma_1 N_{K2}|I_{G2}| \sin \sigma_2] \\ &= N_{K1}^2 |I_{G1}|^2 + N_{K2}^2 |I_{G2}|^2 + 2N_{K1}N_{K2}|I_{G1}||I_{G2}| \cos(\sigma_1 - \sigma_2) \end{aligned}$$

$$\text{Now } |I_{G1}| = \frac{P_{G1}}{\sqrt{3}|V_1| \cos \phi_1} \text{ and } |I_{G2}| = \frac{P_{G2}}{\sqrt{3}|V_2| \cos \phi_2}$$

Where P_{G1} , P_{G2} are three phase real power outputs of plant 1 and plant 2; V_1 , V_2 are the line to line bus voltages of the plants and ϕ_1 and ϕ_2 are the power factor angles.

The total transmission loss in the system is given by

$$P_L = \sum_K 3|I_K|^2 R_K$$

Where the summation is taken over all branches of the network and R_K is the branch resistance. Substituting we get

$$P_L = \frac{P_{G1}^2}{|V_1|^2 (\cos \phi_1)^2} \sum_K N_{K1}^2 R_K + \frac{2P_{G1}P_{G2} \cos(\sigma_1 - \sigma_2)}{|V_1||V_2| \cos \phi_1 \cos \phi_2} \sum_K N_{K1}N_{K2} R_K + \frac{P_{G2}^2}{|V_2|^2 (\cos \phi_2)^2} \sum_K N_{K2}^2 R_K$$

$$P_L = P_{G1}^2 B_{11} + 2P_{G1} P_{G2} B_{12} + P_{G2}^2 B_{22}$$

where
$$B_{11} = \frac{1}{|V_1|^2 (\cos \phi_1)^2} \sum_K N_{K1}^2 R_K$$

$$B_{12} = \frac{\cos(\sigma_1 - \sigma_2)}{|V_1||V_2| \cos \phi_1 \cos \phi_2} \sum_K N_{K1} N_{K2} R_K$$

$$B_{22} = \frac{1}{|V_2|^2 (\cos \phi_2)^2} \sum_K N_{K2}^2 R_K$$

The loss – coefficients are called the B – coefficients and have unit MW⁻¹

For a general system with n plants the transmission loss is expressed as

$$P_L = \frac{P_{G1}^2}{|V_1|^2 (\cos \phi_1)^2} \sum_K N_{K1}^2 + \dots + \frac{P_{Gn}^2}{|V_n|^2 (\cos \phi_n)^2} \sum_K N_{Kn}^2 R_K + 2 \sum_{\substack{p,q=1 \\ p \neq q}}^n \frac{P_{Gp} P_{Gq} \cos(\sigma_p - \sigma_q)}{|V_p||V_q| \cos \phi_p \cos \phi_q} \sum_K N_{Kp} N_{Kq} R_K$$

In a compact form

$$P_L = \sum_{p=1}^n \sum_{q=1}^n P_{Gp} B_{pq} P_{Gq}$$

$$B_{pq} = \frac{\cos(\sigma_p - \sigma_q)}{|V_p||V_q| \cos \phi_p \cos \phi_q} \sum_K N_{Kp} N_{Kq} R_K$$

B – Coefficients can be treated as constants over the load cycle by computing them at average operating conditions, without significant loss of accuracy.

Economic Sharing of Loads between Different Plants

So far we have considered the economic operation of a single plant in which we have discussed how a particular amount of load is shared between the different units of a plant. In this problem we did not have to consider the transmission line losses and assumed that the losses were a part of the load supplied. However if now consider how a load is distributed between the different plants that are joined by transmission lines, then the line losses have to be explicitly included in the economic dispatch problem. In this section we shall discuss this problem.

When the transmission losses are included in the economic dispatch problem

$$P_T = P_1 + P_2 + \dots + P_N - P_{Loss} \quad (2.1)$$

$$0 = dP_1 + dP_2 + \dots + dP_N - dP_{Loss} \quad (2.2)$$

Where P_{Loss} is the total line loss. Since P_T is assumed to be constant, we have

$$dP_{Loss} = \frac{\partial P_{Loss}}{\partial P_1} dP_1 + \frac{\partial P_{Loss}}{\partial P_2} dP_2 + \dots + \frac{\partial P_{Loss}}{\partial P_N} dP_N \quad \dots\dots\dots (2.3)$$

In the above equation dP_{Loss} includes the power loss due to every generator, i.e.,

Also minimum generation cost implies $df_T = 0$ as given in (1.5). Multiplying both (2.2) and (2.3) by λ and combining we get

$$0 = \left(\lambda \frac{\partial P_{Loss}}{\partial P_1} - \lambda \right) dP_1 + \left(\lambda \frac{\partial P_{Loss}}{\partial P_2} - \lambda \right) dP_2 + \dots + \left(\lambda \frac{\partial P_{Loss}}{\partial P_N} - \lambda \right) dP_N \quad (2.4)$$

$$0 = \sum_{i=1}^N \left(\frac{\partial f_T}{\partial P_i} + \lambda \frac{\partial P_{Loss}}{\partial P_i} - \lambda \right) dP_i \quad (2.5)$$

Adding (2.4) with (1.5) we obtain

$$\frac{\partial f_T}{\partial P_i} + \lambda \frac{\partial P_{Loss}}{\partial P_i} - \lambda = 0, \quad i = 1, \dots, N \quad (2.6)$$

The above equation satisfies when

$$\frac{\partial f_T}{\partial P_i} = \frac{df_T}{dP_i}, \quad i = 1, \dots, N$$

Again since

$$\lambda = \frac{df_1}{dP_1} L_1 = \frac{df_2}{dP_2} L_2 = \dots = \frac{df_N}{dP_N} L_N \quad (2.7)$$

From (2.6) we get

$$L_i = \frac{1}{1 - \partial P_{Loss} / \partial P_i}, \quad i = 1, \dots, N \quad (2.8)$$

Where L_i is called the **penalty factor** of load- i and is given by

$$P = [P_1 \quad P_2 \quad \dots \quad P_N]^T$$

Consider an area with N number of units. The power generated are defined by the vector

$$P_{Loss} = P^T B P \quad (2.9)$$

Then the transmission losses are expressed in general as

Where B is a symmetric matrix given by

$$B = \begin{bmatrix} B_{11} & B_{12} & \cdots & B_{1N} \\ B_{12} & B_{22} & \cdots & B_{2N} \\ \vdots & \vdots & \ddots & \vdots \\ B_{1N} & B_{2N} & \cdots & B_{NN} \end{bmatrix}$$

The elements B_{ij} of the matrix B are called the **loss coefficients**. These coefficients are not constant but vary with plant loading. However for the simplified calculation of the penalty factor L_i these coefficients are often assumed to be constant.

When the incremental cost equations are linear, we can use analytical equations to find out the economic settings. However in practice, the incremental costs are given by nonlinear equations that may even contain nonlinearities. In that case iterative solutions are required to find the optimal generator settings.

UNIT-II

HYDROTHERMAL SCHEDULING LONG

Long-Range Hydro-Scheduling:

The long-range hydro-scheduling problem involves the long-range forecasting of water availability and the scheduling of reservoir water releases (i.e., “drawdown”) for an interval of time that depends on the reservoir capacities. Typical long range scheduling goes anywhere from 1 wk to 1 yr or several years. For hydro schemes with a capacity of impounding water over several seasons, the long-range problem involves meteorological and statistical analyses.

Short-Range Hydro-Scheduling

Short-range hydro-scheduling (1 day to 1 wk) involves the hour-by-hour scheduling of all generation on a system to achieve minimum production cost for the given time period. In such a scheduling problem, the load, hydraulic inflows, and unit availabilities are assumed known. A set of starting conditions (e.g., reservoir levels) is given, and the optimal hourly schedule that minimizes a desired objective, while meeting hydraulic steam, and electric system constraints, is sought.

Hydrothermal systems where the hydroelectric system is by far the largest component may be scheduled by economically scheduling the system to produce the minimum cost for the thermal system. The schedules are usually developed to minimize thermal generation production costs, recognizing all the diverse hydraulic constraints that may exist

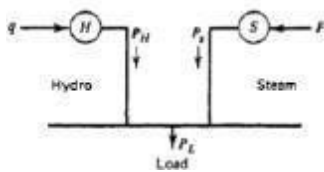

2.8 OPTIMAL POWER FLOW PROBLEM: Basic approach to the solution of this problem is to incorporate the power flow equations as essential constraints in the formal establishment of the optimization problem. This general approach is known as the optimal power flow. Another approach is by using loss-formula method. Different techniques are: 1) the lambda-iteration method 2) Gradient methods of economic dispatch 3) Newton's method 4) Economic dispatch with piecewise linear cost functions 5) Economic dispatch using dynamic programming

UNIT – III**Modeling of Power System Components****Introduction**

The main objective of power system operation and control is to maintain continuous supply of power with an acceptable quality, to all the consumers in the system. The system will be in equilibrium, when there is a balance between the power demand and the power generated. As the power in AC form has real and reactive components: the real power balance; as well as the reactive power balance is to be achieved. There are two basic control mechanisms used to achieve reactive power balance (acceptable voltage profile) and real power balance (acceptable frequency values). The former is called the automatic voltage regulator (AVR) and the latter is called the automatic load frequency control (ALFC) or automatic generation control (AGC).

Generator Voltage Control System

The voltage of the generator is proportional to the speed and excitation (flux) of the generator. The speed being constant, the excitation is used to control the voltage. Therefore, the voltage control system is also called as excitation control system or automatic voltage regulator (AVR).

For the alternators, the excitation is provided by a device (another machine or a static device) called exciter. For a large alternator the exciter may be required to supply a field current of as large as 6500A at 500V and hence the exciter is a fairly large machine. Depending on the way the dc supply is given to the field winding of the alternator (which is on the rotor), the exciters are classified as: i) DC Exciters; ii) AC Exciters; and iii) Static Exciters. Accordingly, several standard block diagrams are developed by the IEEE working group to represent the excitation system. A schematic of an excitation control system is shown in Fig2.1.

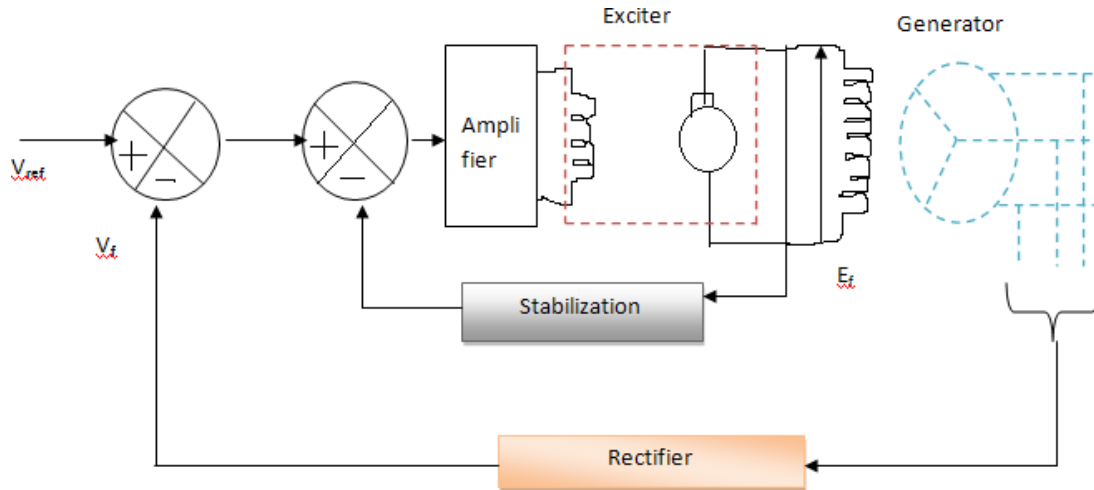

A schematic of excitation (voltage) control system

Fig2.1: A schematic of Excitation (Voltage) Control System.

A simplified block diagram of the generator voltage control system is shown in Fig2.2. The generator terminal voltage V_t is compared with a voltage reference V_{ref} to obtain a voltage error signal $_V$. This signal is applied to the voltage regulator shown as a block with transfer function $K_A / (1 + sT_A)$. The output of the regulator is then applied to exciter shown with a block of transfer function $K_e / (1 + sT_e)$. The output of the exciter e.m.f is then applied to the field winding which adjusts the generator terminal voltage. The generator field can be represented by a block with a transfer function $K_F / (1 + sT_F)$. The total transfer function is

$$\frac{\Delta V}{\Delta V_{ref}} = \frac{G(s)}{1 + G(s)} \quad \text{where, } G(s) = \frac{K_A K_e K_F}{(1 + sT_A)(1 + sT_e)(1 + sT_F)}$$

The stabilizing compensator shown in the diagram is used to improve the dynamic response of the exciter. The input to this block is the exciter voltage and the output is a stabilizing feedback signal to reduce the excessive overshoot.

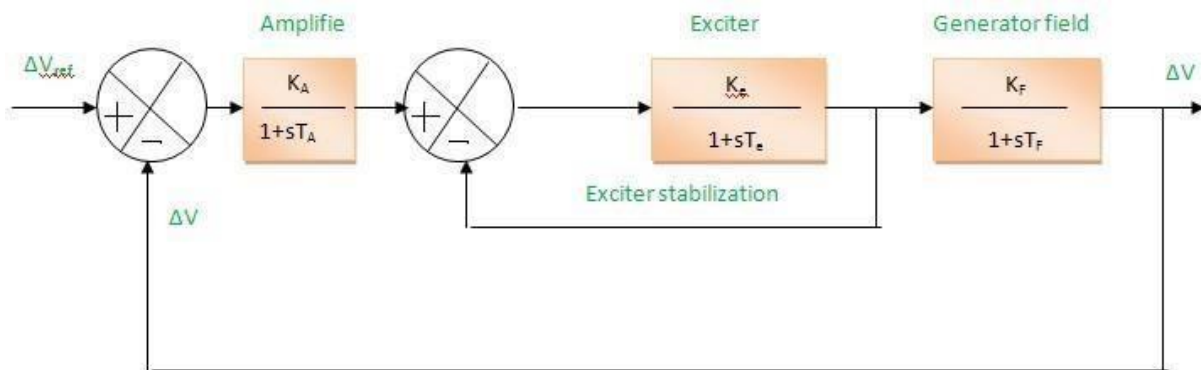

A simplified block diagram of voltage (excitation) control system

Fig2.2: A simplified block diagram of Voltage (Excitation) Control System.**Performance of AVR Loop**

The purpose of the AVR loop is to maintain the generator terminal voltage with unacceptable values. A static accuracy limit in percentage is specified for the AVR, so that the terminal voltage is maintained within that value. For example, if the accuracy limit is 4%, then the terminal voltage must be maintained within 4% of the base voltage.

The performance of the AVR loop is measured by its ability to regulate the terminal voltage of the generator within prescribed static accuracy limit with an acceptable speed of response. Suppose the static accuracy limit is denoted by A_c in percentage with reference to the nominal value. The error voltage is to be less than $(A_c/100) |V_{ref}$. From the block diagram, for a steady state error voltage

$$\begin{aligned} \Delta e &= \Delta |V|_{ref} - \Delta |V|_t < \frac{A_c}{100} \Delta |V|_{ref} \\ \Delta e &= \Delta |V|_{ref} - \Delta |V|_t = \Delta |V|_{ref} - \frac{G(s)}{1+G(s)} \Delta |V|_{ref} \\ &= \left\{ 1 - \frac{G(s)}{1+G(s)} \right\} \Delta |V|_{ref} \\ \Delta e &= \left\{ 1 - \frac{G(s)}{1+G(s)} \right\} \Delta |V|_{ref} = \left\{ 1 - \frac{G(0)}{1+G(0)} \right\} \Delta |V|_{ref} \\ &= \frac{1}{1+G(0)} \Delta |V|_{ref} = \frac{1}{1+K} \Delta |V|_{ref} \end{aligned}$$

For constant input condition, ($s \rightarrow 0$)

Where, $K = G(0)$ is the open loop gain of the AVR. Hence,

$$\frac{1}{1+K} \Delta |V|_{ref} < \frac{A_c}{100} \Delta |V|_{ref} \quad \text{or} \quad K > \left\{ \frac{100}{A_c} - 1 \right\}$$

Automatic Load Frequency Control

The ALFC is to control the frequency deviation by maintaining the real power balance in the system. The main functions of the ALFC are to i) to maintain the steady frequency; ii) control the tie-line flows; and iii) distribute the load among the participating generating units. The control (input) signals are the tie-line deviation ΔP_{tie} (measured from the tie line flows), and the frequency deviation Δf (obtained by measuring the angle deviation $\Delta \delta$). These error signals Δf and ΔP_{tie} are amplified, mixed and transformed to a real

power signal, which then controls the valve position. Depending on the valve position, the turbine (prime mover) changes its output power to establish the real power balance. The complete control schematic is shown in Fig2.3

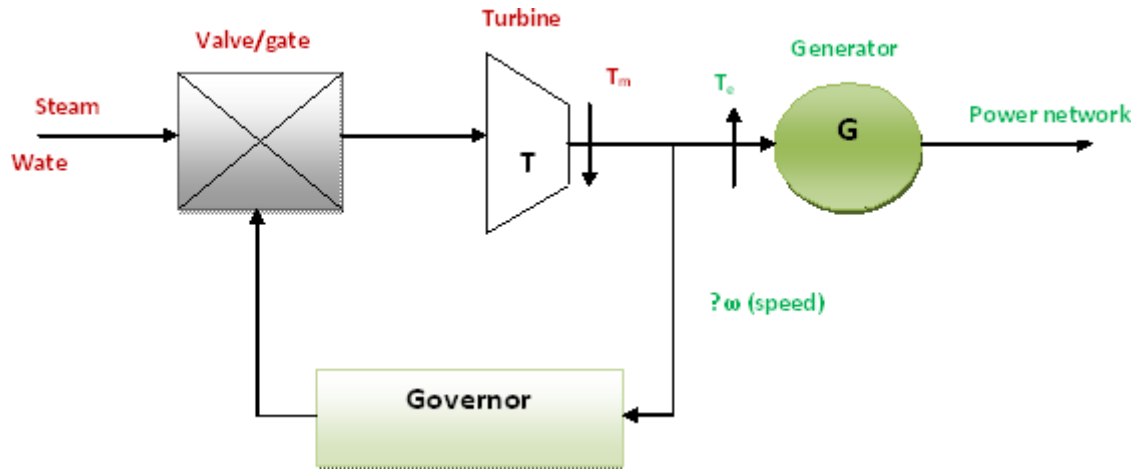

Fig2.3. The Schematic representation of ALFC system

For the analysis, the models for each of the blocks in Fig2 are required. The generator and the electrical load constitute the power system. The valve and the hydraulic amplifier represent the speed governing system. Using the swing equation, the generator can be modeled by

$$\frac{2Hd^2\Delta\delta}{\omega_s dt^2} = \Delta P_m - \Delta P_e$$

Expressing the speed deviation in pu,

$$\frac{d\Delta\omega}{dt} = \frac{1}{2H} (\Delta P_m - \Delta P_e)$$

This relation can be represented as shown in Fig2.4.

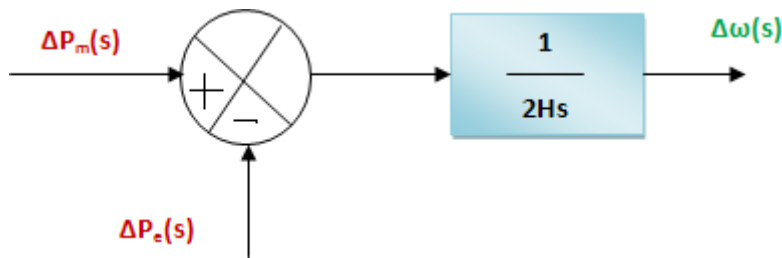

Fig2.4. The block diagram representation of the Generator

The load on the system is composite consisting of a frequency independent component and a frequency dependent component. The load can be written as $\Delta P_e = \Delta P_0 + \Delta P_f$ where, ΔP_e is the change in the load; ΔP_0 is the frequency independent load component; ΔP_f is the frequency dependent load component. $\Delta P_f = D\Delta\omega$ where, D is called frequency characteristic of the load (also called as damping constant) expressed in percent change in load for 1% change in frequency. If $D=1.5\%$, then a 1% change in frequency causes 1.5% change in load. The combined generator and the load (constituting the power system) can then be represented as shown in Fig2.5

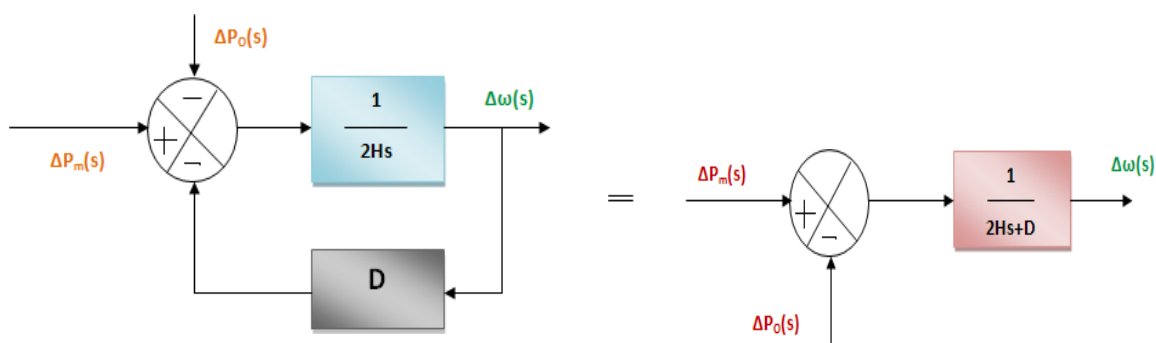

Fig2.5. The block diagram representation of the Generator and load

The turbine can be modeled as a first order lag as shown in the Fig2.6

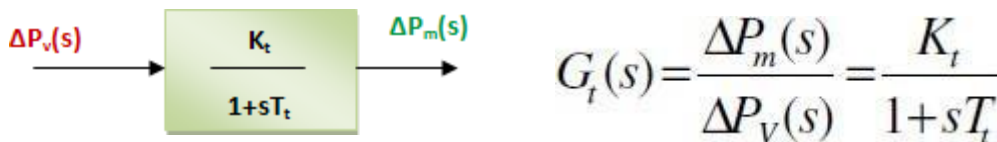

Fig2.6. The turbine model

$G_t(s)$ is the TF of the turbine; $\Delta P_V(s)$ is the change in valve output (due to action).

$\Delta P_m(s)$ is the change in the turbine output the governor can similarly modeled as shown in Fig2.7. The output of the governor is by

$$\Delta P_g = \Delta P_{ref} - \frac{\Delta\omega}{R}$$

where ΔP_{ref} is the reference set power, and $\Delta\omega/R$ is the power given

by governor speed characteristic. The hydraulic amplifier transforms this signal ΔP_g into valve/gate position corresponding to a power ΔP_V . Thus $\Delta P_V(s) = (K_g / (1 + sT_g)) \Delta P_g(s)$.

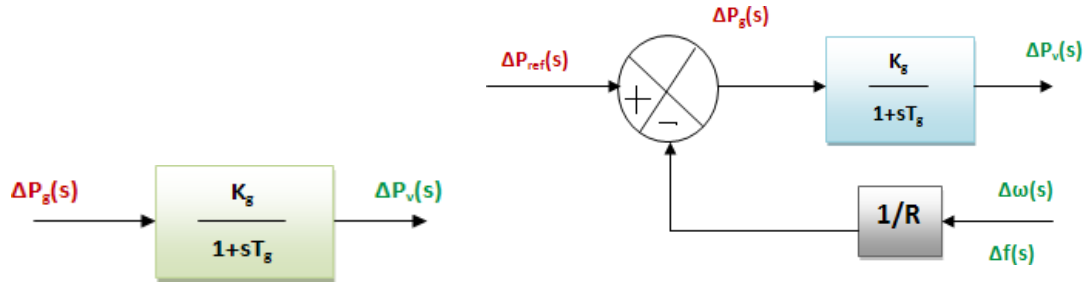

Fig2.7: The block diagram representation of the Governor

All the individual blocks can now be connected to represent the complete ALFC loop as Shown in Fig 5.1

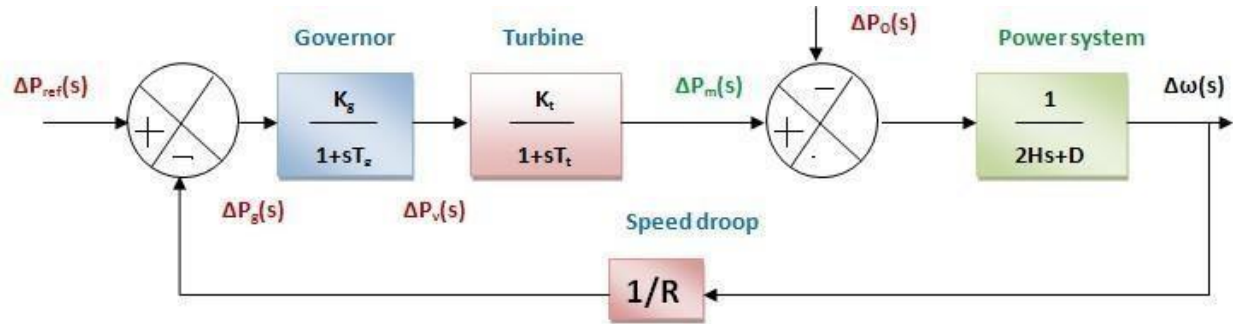

Fig2.8: The block diagram representation of the ALFC.

2.2 Steady state Performance of the ALFC Loop:

In the steady state, the ALFC is in „open“ state, and the output is obtained by substituting $S \rightarrow 0$ in the TF.

With $S \rightarrow 0$,

2.4 Steady State Performance of the ALFC Loop

In the steady state, the ALFC is in 'open' state, and the output is obtained by substituting $s \rightarrow 0$ in the TF.

With $s \rightarrow 0$, $G_g(s)$ and $G_t(s)$ become unity, then, (note that $\Delta P_m = \Delta P_T = \Delta P_G = \Delta P_e = \Delta P_D$; That is turbine output = generator/electrical output = load demand)

$$\Delta P_m = \Delta P_{ref} - (1/R)\Delta\omega \quad \text{or} \quad \Delta P_m = \Delta P_{ref} - (1/R)\Delta f$$

When the generator is connected to infinite bus ($\Delta f = 0$, and $\Delta V = 0$), then $\Delta P_m = \Delta P_{ref}$.

If the network is finite, for a fixed speed changer setting ($\Delta P_{ref} = 0$), then

$$\Delta P_m = -(1/R)\Delta f \quad \text{or} \quad \Delta f = -R \Delta P_m.$$

If the frequency dependent load is present, then

$$\Delta P_m = \Delta P_{ref} - (1/R + D)\Delta f \quad \text{or} \quad \Delta f = \frac{-\Delta P_m}{D + 1/R}$$

If there are more than one generator present in the system, then

$$\Delta P_{m,eq} = \Delta P_{ref,eq} - (D + 1/R_{eq})\Delta f$$

where,

$$\Delta P_{m,eq} = \Delta P_{m1} + \Delta P_{m2} + \Delta P_{m3} + \dots$$

$$\Delta P_{ref,eq} = \Delta P_{ref1} + \Delta P_{ref2} + \Delta P_{ref3} + \dots$$

$$1/R_{eq} = (1/R_1 + 1/R_2 + 1/R_2 + \dots)$$

The quantity $\beta = (D + 1/R_{eq})$ is called the area frequency (bias) characteristic (response) or simply the stiffness of the system.

2.5 Concept of AGC (Supplementary ALFC Loop)

The ALFC loop shown in Fig2.8, is called the primary ALFC loop. It achieves the primary goal of real power balance by adjusting the turbine output ΔP_m to match the change in load demand ΔP_D . All the participating generating units contribute to the change in generation. But a change in load results in a steady state frequency deviation Δf . The restoration of the frequency to the nominal value requires an additional control loop called the supplementary loop. This objective is met by using integral controller which makes the frequency deviation zero. The ALFC with the supplementary loop is generally called the AGC. The block diagram of an AGC is shown in Fig2.9. The main objectives of AGC are i) to regulate the frequency (using both primary and supplementary controls); ii) and to maintain the scheduled tie-line flows. A secondary objective of the

AGC is to distribute the required change in generation among the connected generating units economically (to obtain least operating costs).

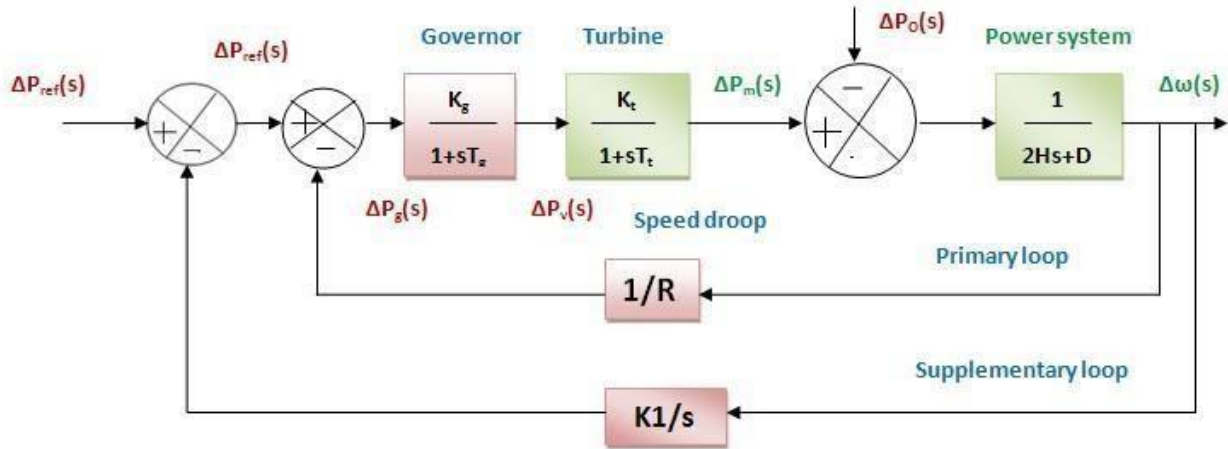

Fig2.9: The block diagram representation of the AGC

2.6 AGC in a Single Area System

In a single area system, there is no tie-line schedule to be maintained. Thus the function of the AGC is only to bring the frequency to the nominal value. This will be achieved using the supplementary loop (as shown in Fig.2.9) which uses the integral controller to change the reference power setting so as to change the speed set point. The integral controller gain K_1 needs to be adjusted for satisfactory response (in terms of overshoot, settling time) of the system. Although each generator will be having a separate speed governor, all the generators in the control area are replaced by a single equivalent generator, and the ALFC for the area corresponds to this equivalent generator.

2.7 AGC in a Multi Area System

In an interconnected (multi area) system, there will be one ALFC loop for each control area (located at the ECC of that area). They are combined as shown in Fig2.10 for the interconnected system operation. For a total change in load of ΔP_D , the steady state deviation in frequency in the two areas is given by $\Delta f = \Delta \omega_1 = \Delta \omega_2 = \frac{-\Delta P_D}{\beta_1 + \beta_2}$ where,

$$\Delta f = \Delta \omega_1 = \Delta \omega_2 = \frac{-\Delta P_D}{\beta_1 + \beta_2} \text{ where,}$$

$$\beta_1 = (D_1 + 1/R_1); \text{ and } \beta_2 = (D_2 + 1/R_2).$$

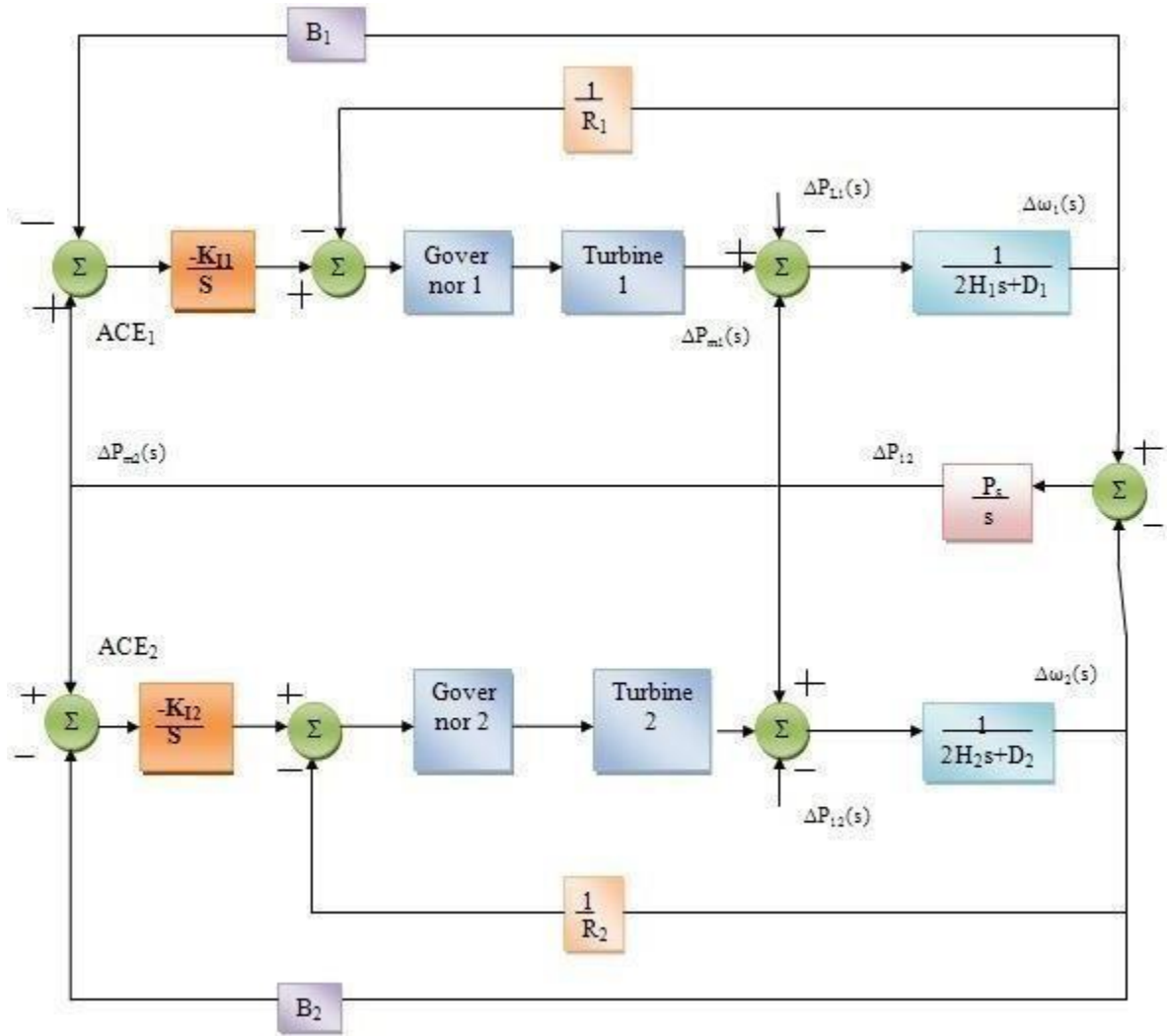

Fig.2.10.AGC for a multi-area operation

2.8 Expression for tie-line flow in a two-area interconnected system

Consider a change in load ΔP_{D1} in area1. The steady state frequency deviation Δf is the same for both the areas. That is $\Delta f = \Delta f_1 = \Delta f_2$. Thus, for area1, we have

$$\Delta P_{m1} - \Delta P_{D1} - \Delta P_{12} = D_1 \Delta f$$

where, ΔP_{12} is the tie line power flow from Area1 to Area 2; and for Area 2

$$\Delta P_{m2} + \Delta P_{12} = D_2 \Delta f$$

The mechanical power depends on regulation. Hence

$$\Delta P_{m1} = -\frac{\Delta f}{R_1} \quad \text{and} \quad \Delta P_{m2} = -\frac{\Delta f}{R_2}$$

Substituting these equations, yields

$$\left(\frac{1}{R_1} + D_1\right)\Delta f = -\Delta P_{12} - \Delta P_{D1} \quad \text{and} \quad \left(\frac{1}{R_2} + D_2\right)\Delta f = \Delta P_{12}$$

Solving for Δf , we get

$$\Delta f = \frac{-\Delta P_{D1}}{(1/R_1 + D_1) + (1/R_2 + D_2)} = \frac{-\Delta P_{D1}}{\beta_1 + \beta_2}$$

and

$$\Delta P_{12} = \frac{-\Delta P_{D1}\beta_2}{\beta_1 + \beta_2}$$

where, β_1 and β_2 are the composite frequency response characteristic of Area1 and Area 2 respectively. An increase of load in area1 by ΔP_{D1} results in a frequency reduction in both areas and a tie-line flow of ΔP_{12} . A positive ΔP_{12} is indicative of flow from Area1 to Area 2 while a negative ΔP_{12} means flow from Area 2 to Area1. Similarly, for a change in Area

2 load by ΔP_{D2} , we have

$$\Delta f = \frac{-\Delta P_{D2}}{\beta_1 + \beta_2}$$

and

$$\Delta P_{12} = -\Delta P_{21} = \frac{-\Delta P_{D2}\beta_1}{\beta_1 + \beta_2}$$

Frequency bias tie line control

The tie line deviation reflects the contribution of regulation characteristic of one area to another. The basic objective of supplementary control is to restore balance between each area load generation. This objective is met when the control action maintains

- Frequency at the scheduled value
- Net interchange power (tie line flow) with neighboring areas at the scheduled

Values

The supplementary control should ideally correct only for changes in that area. In other words, if there is a change in Area 1 load, there should be supplementary control only in Area 1 and not in Area 2. For this purpose the area control error (ACE) is used (Fig 2.9). The ACE of the two areas are given by

$$\text{For area 1: } ACE_1 = \Delta P_{12} + \beta_1 \Delta f$$

$$\text{For area 2: } ACE_2 = \Delta P_{21} + \beta_2 \Delta f$$

Economic Allocation of Generation

An important secondary function of the AGC is to allocate generation so that each generating unit is loaded economically. That is, each generating unit is to generate that amount to meet the present demand in such a way that the operating cost is the minimum. This function is called Economic Load Dispatch (ELD).

Systems with more than two areas

The method described for the frequency bias control for two area system is applicable to multi-area system also.

UNIT – IV

Load Frequency Control

Electric power is generated by converting mechanical energy into electrical energy. The rotor mass, which contains turbine and generator units, stores kinetic energy due to its rotation. This stored kinetic energy accounts for sudden increase in the load. Let us denote the mechanical torque input by T_m and the output electrical torque by T_e . Neglecting the rotational losses, a generator unit is said to be operating in the steady state at a constant speed when the difference between these two elements of torque is zero. In this case we say that the accelerating torque is zero.

$$T_a = T_m - T_e \quad (5.20)$$

When the electric power demand increases suddenly, the electric torque increases. However, without any feedback mechanism to alter the mechanical torque, T_m remains constant. Therefore the accelerating torque given by (5.20) becomes negative causing a deceleration of the rotor mass. As the rotor decelerates, kinetic energy is released to supply the increase in the load. Also note that during this time, the system frequency, which is proportional to the rotor speed, also decreases. We can thus infer that any deviation in the frequency from its nominal value of 50 or 60 Hz is indicative of the imbalance between T_m and T_e . The frequency drops when $T_m < T_e$ and rises when $T_m > T_e$.

The steady state power-frequency relation is shown in Fig. 5.3. In this figure the slope of the ΔP_{ref} line is negative and is given by

$$-R = \frac{\Delta f}{\Delta P_m} \quad (5.21)$$

Where R is called the **regulating constant**. From this figure we can write the steady state power frequency relation as

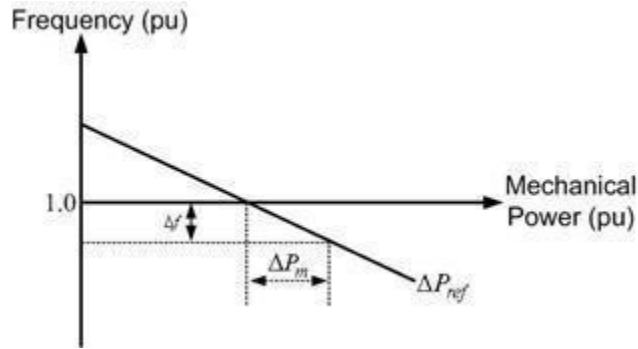

Fig. 5.3 A typical steady-state power-frequency curve.

$$\Delta P_m = \Delta P_{ref} - \frac{1}{R} \Delta f \quad (5.22)$$

Suppose an interconnected power system contains N turbine-generator units. Then the steady-state power frequency relation is given by the summation of (5.22) for each of these units as

$$\begin{aligned} \Delta P_m &= \Delta P_{m1} + \Delta P_{m2} + \dots + \Delta P_{mN} \\ &= (\Delta P_{ref1} + \Delta P_{ref2} + \dots + \Delta P_{refN}) - \left(\frac{1}{R_1} + \frac{1}{R_2} + \dots + \frac{1}{R_N} \right) \Delta f \\ (5.23) \quad &= \Delta P_{ref} - \left(\frac{1}{R_1} + \frac{1}{R_2} + \dots + \frac{1}{R_N} \right) \Delta f \end{aligned}$$

In the above equation, ΔP_m is the total change in turbine-generator mechanical power and ΔP_{ref} is the total change in the reference power settings in the power system. Also note that since all the generators are supposed to work in synchronism, the change in frequency of each of the units is the same and is denoted by Δf . Then the **frequency response characteristics** is defined as

$$\beta = \frac{1}{R_1} + \frac{1}{R_2} + \dots + \frac{1}{R_N} \quad (5.24)$$

We can therefore modify (5.23) as

$$\Delta P_m = \Delta P_{ref} - \beta \Delta f \quad (5.25)$$

Example 5.5

Consider an interconnected 50-Hz power system that contains four turbine-generator units rated 750 MW, 500 MW, 220 MW and 110 MW. The regulating constant of each unit is 0.05 per unit based on its own rating. Each unit is operating on 75% of its own rating when the load is suddenly dropped by 250 MW. We shall choose a common base of 500 MW and calculate the rise in frequency and drop in the mechanical power output of each unit.

The first step in the process is to convert the regulating constant, which is given in per unit in the base of each generator, to a common base. This is given as

$$R_{new} = R_{old} \times \frac{S_{base}^{new}}{S_{base}^{old}} \quad (5.26)$$

We can therefore write

$$R_1 = 0.05 \times \frac{500}{750} = 0.033$$

$$R_2 = 0.05$$

$$R_3 = 0.05 \times \frac{500}{220} = 0.1136$$

$$R_4 = 0.05 \times \frac{500}{110} = 0.2273$$

Therefore

$$\beta = \left(\frac{1}{R_1} + \frac{1}{R_2} + \frac{1}{R_3} + \frac{1}{R_4} \right) = 63.2 \quad \text{Per unit}$$

We can therefore calculate the total change in the frequency from (5.25) while assuming $\Delta P_{ref} = 0$, i.e., for no change in the reference setting. Since the per unit change in load - $250/500 = -0.5$ with the negative sign accounting for load reduction, the change in frequency is given by

$$\begin{aligned} \Delta f &= -\frac{\Delta P_m}{\beta} = -\frac{(-0.5)}{63.2} = 0.0079 \text{ per unit} \\ &= 0.0079 \times 50 = 0.3956 \text{ Hz} \end{aligned}$$

Then the change in the mechanical power of each unit is calculated from (5.22) as

$$\Delta P_{m1} = -\frac{0.0079}{0.033} \times 500 = -118.67 \text{ MW}$$

$$\Delta P_{m2} = -\frac{0.0079}{0.05} \times 500 = -79.11 \text{ MW}$$

$$\Delta P_{m3} = -\frac{0.0079}{0.1136} \times 500 = -34.81 \text{ MW}$$

$$\Delta P_{m4} = -\frac{0.0079}{0.2273} \times 500 = -17.41 \text{ MW}$$

It is to be noted that once ΔP_{m2} is calculated to be - 79.11 MW, we can also calculate the changes in the mechanical power of the other turbine-generators units as

$$\Delta P_{m1} = -79.11 \times \frac{750}{500} = -118.67 \text{ MW}$$

$$\Delta P_{m3} = -79.11 \times \frac{220}{500} = -34.81 \text{ MW}$$

$$\Delta P_{m4} = -79.11 \times \frac{110}{500} = -17.41 \text{ MW}$$

This implies that each turbine-generator unit shares the load change in accordance with its own rating.

Modern day power systems are divided into various areas. For example in India , there are five regional grids, e.g., Eastern Region, Western Region etc. Each of these areas is generally interconnected to its neighboring areas. The transmission lines that connect an area to its neighboring area are called **tie-lines**. Power sharing between two areas occurs through these tie-lines. Load frequency control, as the name signifies, regulates the power flow between different areas while holding the frequency constant.

As we have an [Example 5.5](#) that the system frequency rises when the load decreases if ΔP_{ref} is kept at zero. Similarly the frequency may drop if the load increases. However it is desirable to maintain the frequency constant such that $\Delta f=0$. The power flow through different tie-lines are scheduled - for example, area- i may export a pre-specified amount of power to area- j while importing another pre- specified amount of power from area- k . However it is expected that to fulfill this obligation, area- i absorbs its own load change, i.e., increase generation to supply extra load in the area or decrease generation when the load demand in the area has reduced. While doing this area- i must however maintain its obligation to areas j and k as far as importing and exporting power is concerned. A conceptual diagram of the interconnected areas is shown in Fig. 5.4.

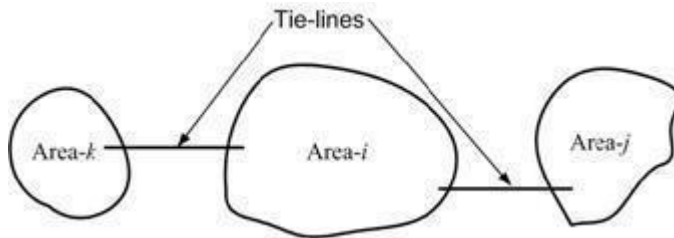

Fig. 5.4 Interconnected areas in a power system

We can therefore state that the load frequency control (LFC) has the following two objectives:

- Hold the frequency constant ($\Delta f = 0$) against any load change. Each area must contribute to absorb any load change such that frequency does not deviate.
- Each area must maintain the tie-line power flow to its pre-specified value.

$$\bullet \quad ACE = (P_{tie} - P_{sch}) + B_f \Delta f = \Delta P_{tie} + B_f \Delta f \quad (5.27)$$

The first step in the LFC is to form the **area control error (ACE)** that is defined as

Where P_{tie} and P_{sch} are **tie-line power** and **scheduled power** through tie-line respectively and the constant B_f is called the **frequency bias constant**.

The change in the reference of the power setting $\Delta P_{ref, i}$, of the area- i is then obtained by

$$\Delta P_{ref,i} = -K_i \int ACE dt \quad (5.28)$$

The feedback of the ACE through an integral controller of the form where K_i is the integral gain. The ACE is negative if the net power flow out of an area is low or if the frequency has dropped or both. In this case the generation must be increased. This can be achieved by increasing $\Delta P_{ref,i}$. This negative sign accounts for this inverse relation between $\Delta P_{ref,i}$ and ACE. The tie-line power flow and frequency of each area are monitored in its control center. Once the ACE is computed and $\Delta P_{ref,i}$ is obtained from (5.28), commands are given to various turbine-generator controls to adjust their reference power settings.

Example 5.6

Consider a two-area power system in which area-1 generates a total of 2500 MW, while area-2 generates 2000 MW. Area-1 supplies 200 MW to area-2 through the inter-tie lines connected between the two areas. The bias constant of area-1 (β_1) is 875 MW/Hz and that of area-2 (β_2) is 700 MW/Hz. With the two areas operating in the steady state, the load of area-2 suddenly increases by 100 MW. It is desirable that area-2 absorbs its own load change while not allowing the frequency to drift.

The area control errors of the two areas are given by

$$ACE_1 = \Delta P_{tie1} + B_1 \Delta f_1 \quad \text{And} \quad ACE_2 = \Delta P_{tie2} + B_2 \Delta f_2$$

Since the net change in the power flow through tie-lines connecting these two areas must be zero, we have

$$\Delta P_{tie1} + \Delta P_{tie2} = 0 \Rightarrow \Delta P_{tie1} = -\Delta P_{tie2}$$

Also as the transients die out, the drift in the frequency of both these areas is assumed to be constant, i.e.

$$\Delta f_1 = \Delta f_2 = \Delta f$$

If the load frequency controller (5.28) is able to set the power reference of area-2 properly, the ACE of the two areas will be zero, i.e., $ACE_1 = ACE_2 = 0$. Then we have

$$ACE_1 + ACE_2 = (B_1 + B_2) \Delta f = 0$$

This will imply that Δf will be equal to zero while maintaining $\Delta P_{tie1} = \Delta P_{tie2} = 0$. This signifies that area-2 picks up the additional load in the steady state.

Coordination between LFC and Economic Dispatch

Both the load frequency control and the economic dispatch issue commands to change the power setting of each turbine-governor unit. At a first glance it may seem that these two commands can be conflicting. This however is not true. A typical automatic generation control strategy is shown in Fig. 5.5 in which both the objectives are coordinated. First we compute the area control error. A share of this ACE, proportional to α_i , is allocated to each of the turbine-generator unit of an area. Also the share of unit- i , $\gamma_i \sum (P_{DK} - P_k)$, for the deviation of total generation from actual generation is computed. Also the error

between the economic power setting and actual power setting of unit- i is computed. All these signals are then combined and passed through a proportional gain K_i to obtain the turbine-governor control signal.

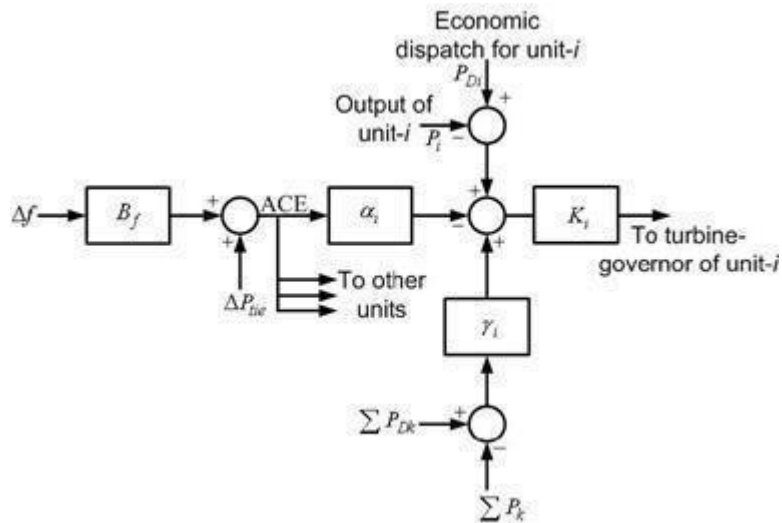

Fig. 5.5 Automatic generation control of unit-i

Section II: Swing Equation

Let us consider a three-phase synchronous alternator that is driven by a prime mover. The equation of motion of the machine rotor is given by

$$J \frac{d^2\theta}{dt^2} = T_m - T_e = T_a$$

Where

| | |
|----------|--|
| J | is the total moment of inertia of the rotor mass in kgm^2 |
| T_m | is the mechanical torque supplied by the prime mover in N-m |
| T_e | is the electrical torque output of the alternator in N-m |
| θ | is the angular position of the rotor in rad |

Neglecting the losses, the difference between the mechanical and electrical torque gives the net accelerating torque T_a . In the steady state, the electrical torque is equal to the mechanical torque, and hence the accelerating power will be zero. During this period the rotor will move at **synchronous speed** ω_s in rad/s. The angular position θ is measured with a stationary reference frame. To represent it with respect to the synchronously rotating frame, we define

$$\theta = \omega_s t + \delta \tag{9.7}$$

Where δ is the angular position in radians with respect to the synchronously rotating

$$I_s = \frac{V_1 \angle \delta - V_2}{jX} = \frac{V_1 \cos \delta - V_2 + jV_1 \sin \delta}{jX} \quad (9.8)$$

Reference frame. Taking the time derivative of the above equation we get

Defining the angular speed of the rotor as

$$\omega_r = \frac{d\theta}{dt}$$

We can write (9.8) as

$$\omega_r - \omega_s = \frac{d\delta}{dt} \quad (9.9)$$

We can therefore conclude that the rotor angular speed is equal to the synchronous speed only when $d\delta/dt$ is equal to zero. We can therefore term $d\delta/dt$ as the error in speed.

$$J \frac{d^2 \delta}{dt^2} = T_m - T_e = T_a \quad (9.10)$$

Taking derivative of (9.8), we can then rewrite (9.6) as Multiplying both side of (9.11) by ω_m we get

$$J \omega_r \frac{d^2 \delta}{dt^2} = P_m - P_e = P_a \quad (9.11)$$

Where P_m , P_e and P_a respectively are the mechanical, electrical and accelerating power in MW.

$$H = \frac{\text{Stored kinetic energy at synchronous speed in mega - joules}}{\text{Generator MVA rating}} = \frac{J \omega_s^2}{2S_{rated}} \quad (9.12)$$

We now define a normalized inertia constant as Substituting (9.12) in (9.10) we get

$$2H \frac{S_{rated}}{\omega_s^2} \omega_r \frac{d^2 \delta}{dt^2} = P_m - P_e = P_a \quad (9.13)$$

In steady state, the machine angular speed is equal to the synchronous speed and hence we can replace ω_r in the above equation by ω_s . Note that in (9.13) P_m , P_e and P_a are given in MW. Therefore dividing them by the generator MVA rating S_{rated} we can get these quantities in per unit. Hence dividing both sides of (9.13) by S_{rated} we get

$$\frac{2H}{\omega_s} \frac{d^2 \delta}{dt^2} = P_m - P_e = P_a \quad \text{per unit} \quad (9.14)$$

Equation (9.14) describes the behavior of the rotor dynamics and hence is known as the swing equation. The angle δ is the angle of the internal emf of the generator and it dictates the amount of power that can be transferred. This angle is therefore called the **load angle**.

Example 9.2

A 50 Hz, 4-pole turbo generator is rated 500 MVA, 22 kV and has an inertia constant (H) of 7.5. Assume that the generator is synchronized with a large power system and has a zero accelerating power while delivering a power of 450 MW. Suddenly its input power is changed to 475 MW. We have to find the speed of the generator in rpm at the end of a period of 10 cycles. The rotational losses are assumed to be zero.

We then have

$$\begin{aligned}\frac{d^2\delta}{dt^2} &= \frac{\omega_s}{2H}(P_m - P_e) = \frac{100\pi}{15} \times 25 = 523.6 \text{ electrical deg/s}^2 \\ &= \frac{523.6\pi}{180} = 9.1385 \text{ electrical rad/s}^2\end{aligned}$$

Noting that the generator has four poles, we can rewrite the above equation as

$$\begin{aligned}\frac{d^2\delta}{dt^2} &= \frac{9.1385}{2} = 4.5693 \text{ mechanical rad/s}^2 \\ &= 60 \times \frac{4.5693}{2\pi} = 43.6332 \text{ rpm/s}\end{aligned}$$

The machine accelerates for 10 cycles, i.e., $20 \times 10 = 200 \text{ ms} = 0.2 \text{ s}$, starting with a synchronous speed of 1500 rpm. Therefore at the end of 10 cycles

$$\text{Speed} = 1500 + 43.6332 \times 0.2 = 1508.7266 \text{ rpm.}$$

Unit- V

Reactive power compensation

Compensation of Power Transmission Systems

Introduction

Ideal Series Compensator

- Impact of Series Compensator on Voltage Profile
- Improving Power-Angle Characteristics
- An Alternate Method of Voltage Injection
- Improving Stability Margin
- Comparisons of the Two Modes of Operation

Power Flow Control and Power Swing Damping

Introduction

The two major problems that the modern power systems are facing are voltage and angle stabilities. There are various approaches to overcome the problem of stability arising due to small signal oscillations in an interconnected power system. As mentioned in the previous chapter, installing power system stabilizers with generator excitation control system provides damping to these oscillations. However, with the advancement in the power electronic technology, various reactive power control equipment are increasingly used in power transmission systems.

A power network is mostly reactive. A synchronous generator usually generates active power that is specified by the mechanical power input. The reactive power supplied by the generator is dictated by the network and load requirements. A generator usually does not have any control over it. However the lack of reactive power can cause voltage collapse in a system. It is therefore important to supply/absorb excess reactive power to/from the network. Shunt compensation is one possible approach of providing reactive power support.

A device that is connected in parallel with a transmission line is called a **shunt compensator**, while a device that is connected in series with the transmission line is called a *series compensator*. These are referred to as compensators since they compensate for the reactive power in the ac system. We shall assume that the shunt compensator is always connected at the midpoint of transmission system, while the

- voltage profile
- power-angle characteristics
- stability margin
- damping to power oscillations

- A **static var compensator (SVC)** is the first generation shunt compensator. It has been around since 1960s. In the beginning it was used for load compensation such as to provide var support for large industrial loads, for flicker mitigation etc. However with the advancement of semiconductor technology, the SVC started appearing in the transmission systems in 1970s. Today a large number of SVCs are connected to many transmission systems all over the world. An SVC is constructed using the thyristors technology and therefore does not have gate turn off capability.
- With the advancement in the power electronic technology, the application of a gate turn off thyristors (GTO) to high power application became commercially feasible. With this the second generation shunt compensator device was conceptualized and constructed. These devices use synchronous voltage sources for generating or absorbing reactive power. A synchronous voltage source (SVS) is constructed using a voltage source converter (VSC). Such a shunt compensating device is called **static compensator or STATCOM**. A STATCOM usually contains an SVS that is driven from a dc storage capacitor and the SVS is connected to the ac system bus through an interface transformer. The transformer steps the ac system voltage down such that the voltage rating of the SVS switches are within specified limit. Furthermore, the leakage reactance of the transformer plays a very significant role in the operation of the STATCOM.
- Like the SVC, a **thyristors controlled series compensator (TCSC)** is a thyristors based series compensator that connects a **thyristors controlled reactor (TCR)** in parallel with a fixed capacitor. By varying the firing angle of the anti-parallel thyristors that are connected in series with a reactor in the TCR, the fundamental frequency inductive reactance of the TCR can be changed. This effects a change in the reactance of the TCSC and it can be controlled to produce either inductive or capacitive reactance.
- Alternatively a **static synchronous series compensator or SSSC** can be used for series compensation. An SSSC is an SVS based all GTO based device which contains a VSC. The VSC is driven by a dc capacitor. The output of the VSC is connected to a three-phase transformer. The other end of the transformer is connected in series with the transmission line. Unlike the TCSC, which changes the impedance of the line, an SSSC injects a voltage in the line in quadrature with the line current. By making the SSSC voltage to lead or lag the line current by 90° the SSSC can emulate the behavior of an inductance or capacitance.

In this chapter, we shall discuss the ideal behavior of these compensating devices. For simplicity we shall consider the ideal models and broadly discuss the advantages of series and shunt compensation.

Section I: Ideal Shunt Compensator

- **Improving Voltage Profile**
- **Improving Power-Angle Characteristics**

- **Improving Stability Margin**
- **Improving Damping to Power Oscillations**

The ideal shunt compensator is an ideal current source. We call this an ideal shunt compensator because we assume that it only supplies reactive power and no real power to the system. It is needless to say that this assumption is not valid for practical systems. However, for an introduction, the assumption is more than adequate. We shall investigate the behavior of the compensator when connected in the middle of a transmission line. This is shown in Fig. 10.1, where the shunt compensator, represented by an ideal current source, is placed in the middle of a lossless transmission line. We shall demonstrate that such a configuration improves the four points that are mentioned above.

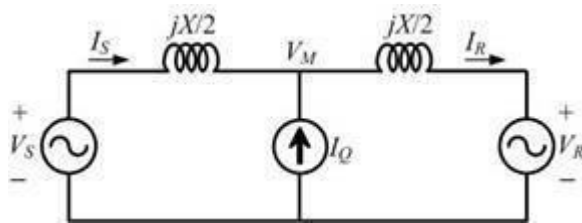

Fig 10.1 Schematic diagram of an ideal, midpoint shunt compensation

Improving Voltage Profile

Let the sending and receiving voltages be given by $V\angle\delta$ and $V\angle\theta$ respectively. The ideal shunt compensator is expected to regulate the midpoint voltage to

$$V_M = V\angle(\delta/2) \quad (10.1)$$

Against any variation in the compensator current. The voltage current characteristic of the compensator is shown in Fig. 10.2. This ideal behavior however is not feasible in practical systems where we get a slight droop in the voltage characteristic. This will be discussed later.

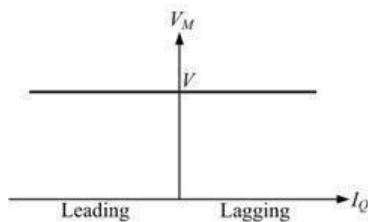

Fig. 10.2 Voltage-current characteristic of an ideal shunt compensator

Under the assumption that the shunt compensator regulates the midpoint voltage tightly as given by (10.1), we can write the following expressions for the sending and receiving end currents

$$I_s = \frac{V\angle\delta - V\angle(\delta/2)}{jX/2} \quad (10.2)$$

$$I_s = \frac{V\angle\delta - V\angle(\delta/2)}{jX/2} \quad (10.3)$$

$$I_s + I_\theta = I_R \quad (10.4)$$

Again from Fig. 10.1 we write

$$I_\theta = -j\frac{4V}{X}\{1 - \cos(\delta/2)\}\angle(\delta/2) \quad (10.5)$$

We thus have to generate a current that is in phase with the midpoint voltage and has a magnitude of $(4V/X_L)\{1 - \cos(\delta/2)\}$. The apparent power injected by the shunt compensator to the ac bus is then

$$P_\theta + jQ_\theta = V_M I_\theta^* = -j\frac{4V^2}{X}\{1 - \cos(\delta/2)\} \quad (10.6)$$

Since the real part of the injected power is zero, we conclude that the ideal shunt compensator injects only reactive power to the ac system and no real power.

Improving Power-Angle Characteristics

The apparent power supplied by the source is given by

$$\begin{aligned} P_s + jQ_s &= V_s I_s^* = V\angle\delta \left[\frac{V\angle -\delta - V\angle -(\delta/2)}{-jX/2} \right] = \frac{V^2 - V\angle(\delta/2)}{-jX/2} \\ &= \frac{2V^2 \sin(\delta/2)}{X} + j\frac{2V^2\{1 - \cos(\delta/2)\}}{X} \end{aligned} \quad (10.7)$$

Similarly the apparent power delivered at the receiving end is

$$\begin{aligned} P_R + jQ_R &= V_R I_R^* = V \left[\frac{V\angle -(\delta/2) - V}{-jX/2} \right] \\ &= \frac{2V^2 \sin(\delta/2)}{X} + j\frac{2V^2\{\cos(\delta/2) - 1\}}{X} \end{aligned} \quad (10.8)$$

$$P_e = P_s = P_R = \frac{2V^2}{X} \sin(\delta/2) \quad (10.9)$$

Hence the real power transmitted over the line is given by

$$Q_e = Q_s + Q_D - Q_R = \frac{8V^2}{X} \{1 - \cos(\delta/2)\} \quad (10.10)$$

The power-angle characteristics of the shunt compensated line are shown in Fig. 10.3. In this figure $P_{max} = V^2/X$ is chosen as the power base.

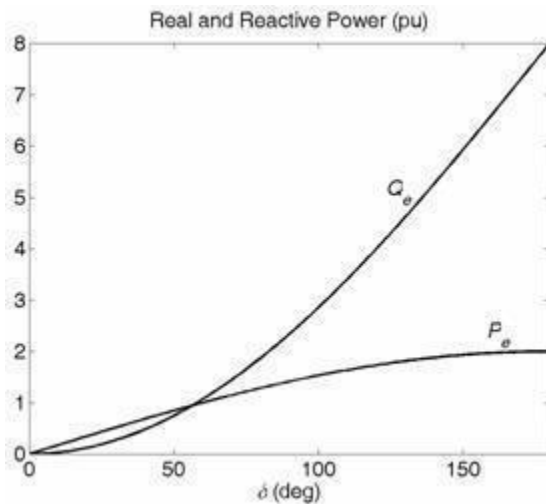

Fig. 10.3 Power-angle characteristics of ideal shunt compensated line.

Fig. 10.3 depicts $P_e - \delta$ and $Q_e - \delta$ characteristics. It can be seen from fig 10.4 that for a real power transfer of 1 per unit, a reactive power injection of roughly 0.5359 per unit will be required from the shunt compensator if the midpoint voltage is regulated as per (10.1). Similarly for increasing the real power transmitted to 2 per unit, the shunt compensator has to inject 4 per unit of reactive power. This will obviously increase the device rating and may not be practical. Therefore power transfer enhancement using midpoint shunt compensation may not be feasible from the device rating point of view.

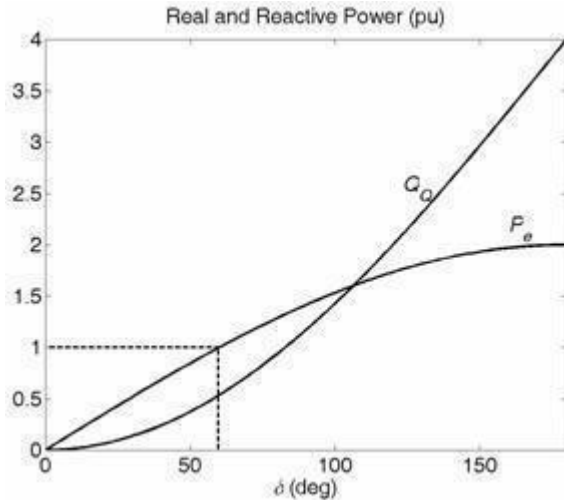

Fig. 10.4 Variations in transmitted real power and reactive power injection by the shunt compensator with load angle for perfect midpoint voltage regulation.

Let us now relax the condition that the midpoint voltage is regulated to 1.0 per unit. We then obtain some very interesting plots as shown in Fig. 10.5. In this figure, the x-axis shows the reactive power available from the shunt device, while the y-axis shows the maximum power that can be transferred over the line without violating the voltage constraint. There are three different P-Q relationships given for three midpoint voltage constraints. For a reactive power injection of 0.5 per unit, the power transfer can be increased from about 0.97 per unit to 1.17 per unit by lowering the midpoint voltage to 0.9 per unit. For a reactive power injection greater than 2.0 per unit, the best power transfer capability is obtained for $V_M =$

per unit. Thus there will be no benefit in reducing the voltage constraint when the shunt device is capable of injecting a large amount of reactive power. In practice, the level to which the midpoint voltage can be regulated depends on the rating of the installed shunt device as well the power being transferred.

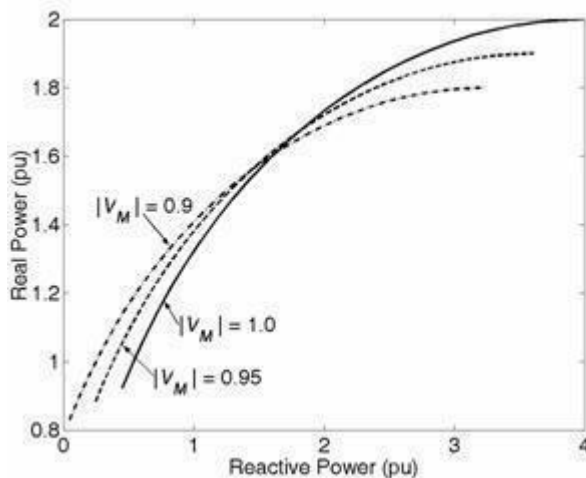
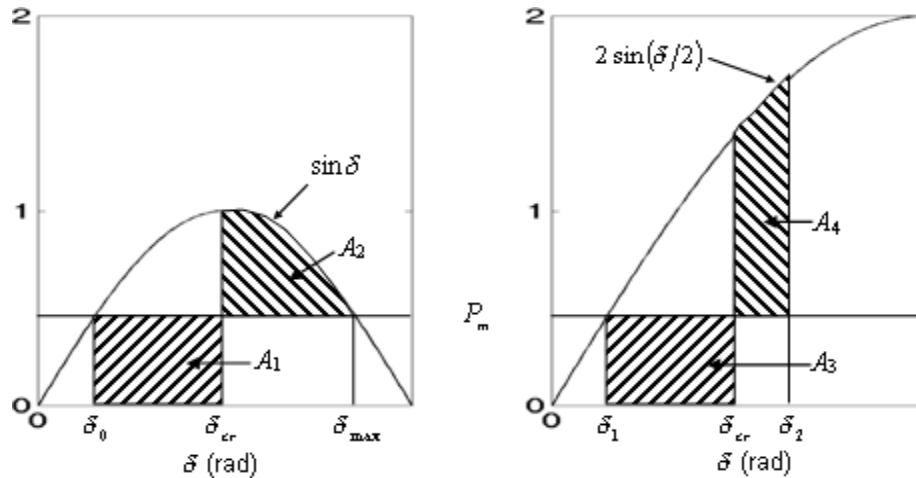

Fig. 10.5 Power transfer versus shunt reactive injection under midpoint voltage constraint.

Improving Stability Margin

This is a consequence of the improvement in the power angle characteristics and is one of the major benefits of using midpoint shunt compensation. As mentioned before, the stability margin of the system pertains to the regions of acceleration and deceleration in the power-angle curve. We shall use this concept to delineate the advantage of midpoint shunt compensation.

Consider the power angle curves shown in Fig. 10.6.



The curve of Fig. 10.6 (a) is for an uncompensated system, while that of Fig. 10.6 (b) for the compensated system. Both these curves are drawn assuming that the base power is V^2/X . Let us assume that the uncompensated system is operating on steady state delivering an electrical power equal to P_m with a load angle of δ_0 when a three-phase fault occurs that forces the real power to zero. To obtain the critical clearing angle for the uncompensated system is δ_{cr} , we equate the accelerating area A_1 with the decelerating area A_2 , where

$$A_1 = \int_{\delta_0}^{\delta_{cr}} P_m dt = P_m (\delta_{cr} - \delta_0)$$

$$A_2 = \int_{\delta_{cr}}^{\delta_{max}} (\sin \delta - P_m) dt = (\cos \delta_{cr} - \cos \delta_{max}) - P_m (\delta_{max} - \delta_{cr})$$

$$\delta_{cr} = \cos^{-1} [P_m (\delta_{max} - \delta_0) + \cos \delta_{max}] \quad (10.11)$$

With $\delta_{max} = \pi - \delta_0$. Equating the areas we obtain the value of δ_{cr} as

Let us now consider that the midpoint shunt compensated system is working with the same mechanical power input P_m . The operating angle in this case is δ_1 and the maximum power that can be transferred in this case is 2 per unit. Let the fault be cleared at the same clearing angle δ_{cr} as before. Then equating areas A_3 and A_4 in Fig. 10.6 (b) we get δ_2 , where

$$A_3 = \int_{\delta_1}^{\delta_{cr}} P_m dt = P_m (\delta_{cr} - \delta_1)$$

$$A_4 = \int_{\delta_{cr}}^{\delta_2} [2 \sin(\delta/2) - P_m] dt = 4[\cos(\delta_{cr}/2) - \cos(\delta_2/2)] - P_m (\delta_2 - \delta_{cr})$$

Example 10.1

Let an uncompensated SMIB power system is operating in steady state with a mechanical power input P_m equal to 0.5 per unit. Then $\delta_0 = 30^\circ = 0.5236$ rad and $\delta_{max} = 150^\circ = 2.6180$ rad. Consequently, the critical clearing angle is calculated as (see Chapter 9) $\delta_{cr} = 79.56^\circ = 1.3886$ rad.

Let us now put an ideal shunt compensator at the midpoint. The pre-fault steady state operating angle of the compensated system can be obtained by solving $2 \sin(\delta/2) = 0.5$, which gives $\delta_1 = 28.96^\circ = 0.5054$ rad. Let us assume that we use the same critical clearing angle as obtained above for clearing a fault in the compensated system as well.

The accelerating area is then given by $A_3 = 0.4416$. Equating with area A_4 we get a nonlinear equation of the form

$$0.4416 = 3.0740 - 4 \cos(\delta_2/2) - 0.5\delta_2 + 0.6943$$

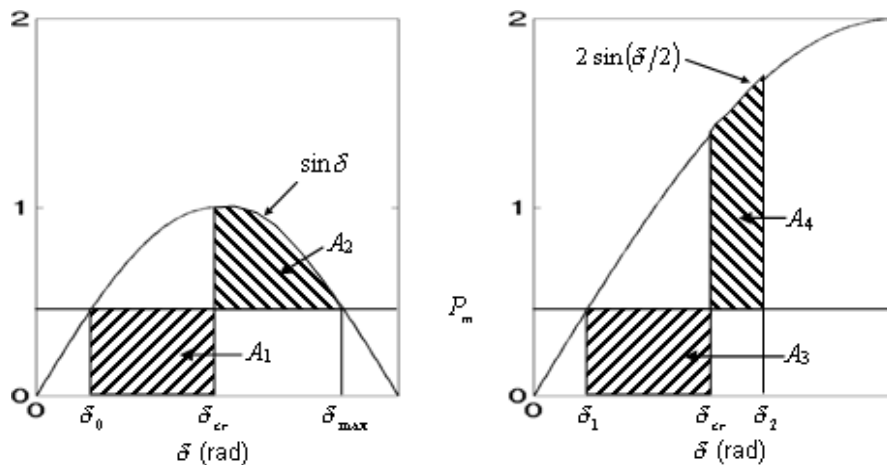

Fig 10.6 Power-angle curve showing clearing angles: (a) for uncompensated system and (b) for compensated system

Solving the above equation we get $\delta_2 = 104.34^\circ = 1.856$ rad. It is needless to say that the stability margin has increased significantly in the compensated system

Improving Damping to Power Oscillations

The swing equation of a synchronous machine is given by (9.14). For any variation in the electrical quantities, the mechanical power input remains constant. Assuming that the magnitude of the midpoint voltage of the system is controllable by the shunt compensating device, the accelerating power in (9.14) becomes a function of two independent variables, $|V_M|$ and δ . Again since the mechanical power is constant, its perturbation with the independent variables is zero. We then get the following small perturbation expression of the swing equation

$$\frac{2H}{\omega} \frac{d^2 \Delta \delta}{dt^2} + \frac{\partial P_e}{\partial |V_M|} \Delta |V_M| + \frac{\partial P_e}{\partial \delta} \Delta \delta = 0 \quad (10.12)$$

Where Δ indicates a perturbation around the nominal values.

If the midpoint voltage is regulated at a constant magnitude, $\Delta |V_M|$ will be equal to zero. Hence the above equation will reduce to

$$\frac{2H}{\omega} \frac{d^2 \Delta \delta}{dt^2} + \frac{\partial P_e}{\partial \delta} \Delta \delta = 0 \quad (10.13)$$

The 2nd order differential equation given in (10.13) can be written in the Laplace domain by neglecting the initial conditions as

$$\left(\frac{2H}{\omega} s^2 + \frac{\partial P_e}{\partial \delta} \right) \Delta \delta(s) = 0 \quad (10.14)$$

The roots of the above equation are located on the imaginary axis of the s-plane at locations $\pm j \omega_m$ where

$$\omega_m = \sqrt{(\omega/2H)(\partial P_e / \partial \delta)}$$

This implies that the load angle will oscillate with a constant frequency of ω_m . Obviously, this solution is not acceptable. Thus in order to provide damping, the midpoint voltage must be varied according to in sympathy with the rate of change in $\Delta\delta$. We can then write

$$\Delta|V_M| = K_M \frac{d\Delta\delta}{dt} \quad (10.15)$$

$$\frac{2H}{\omega} \frac{d^2\Delta\delta}{dt^2} + \frac{\partial P_e}{\partial |V_M|} K_M \frac{d\Delta\delta}{dt} + \frac{\partial P_e}{\partial \delta} \Delta\delta = 0 \quad (10.16)$$

Where K_M is a proportional gain. Substituting (10.15) in (10.12) we get

Provided that K_M is positive definite, the introduction of the control action (10.15) ensures that the roots of the second order equation will have negative real parts. Therefore through the feedback, damping to power swings can be provided by placing the poles of the above equation to provide the necessary damping ratio and undamped natural frequency of oscillations.

Example 10.2

Consider the SMIB power system shown in Fig. 10.7. The generator is connected to the infinite bus through a double circuit transmission line. At the midpoint bus of the lines, a shunt compensator is connected. The shunt compensator is realized by the voltage source V_F that is connected to the midpoint bus through a pure inductor X_F , also known as an **interface inductor**. The voltage source V_F is driven such that it is always in phase with the midpoint voltage V_M . The current I_Q is then purely inductive, its direction being dependent on the relative magnitudes of the two voltages. If the magnitude of the midpoint voltage is higher than the voltage source V_F , inductive current will flow from the ac system to the voltage source. This implies that the source is absorbing var in this configuration. On the other hand, the source will generate var if its magnitude is higher than that of the midpoint voltage.

The system is simulated in MATLAB. The three-phase transmission line equations are simulated using their differential equations, while the generator is represented by a pure voltage source. The second order swing equation is simulated in which the mechanical power input is chosen such that the initial operating angle of the generator voltage is (0.6981 rad). The instantaneous electrical power is computed from the dot product of the three-phase source current vector and source voltage vector. The system parameters chosen for simulation are:

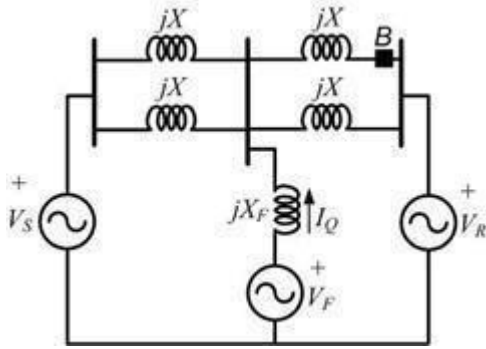

Fig. 10.7 SMIB system used in the numerical example.

| | | | | | | | |
|------------------------|------------|---|---------|---|------------|--------|-------|
| Sending end voltage, | V_S | = | 1 | < | 40° | per | unit, |
| Receiving end voltage, | V_R | = | 1 | < | 0° | per | unit, |
| System Frequency | ω_s | = | 100 | | π | rad/s, | |
| Line reactance, | | | $X=0.5$ | | | per | unit, |
| Interface reactance, | | | X_F | | | per | unit, |

Generator inertia constant, $H=4.0$ MJ/MVA.

Two different tests are performed. In the first one, the midpoint voltage is regulated to 1 per unit using a proportional-plus-integral (PI) controller. The magnitude of the midpoint voltage is first calculated using the d-q transformation of the three phase quantities. The magnitude is then compared with the set reference (1.0) and the error is passed through the PI controller to determine the magnitude of the source voltage, ie,

$$|V_F| = K_P(1 - |V_M|) + K_I \int (1 - |V_M|) dt \quad (10.17)$$

$$V_F = \frac{V_M}{|V_M|} \times |V_F| \quad (10.18)$$

The source voltage is then generated by phase locking it with the midpoint voltage using

Fig. 10.8 depicts the system quantities when the system is perturbed for its nominal operating condition. The proportional gain (K_P) is chosen as 2.0, while the integral gain (K_I) is chosen as 10. In Fig. 10.8 (a) the a-phase of the midpoint voltage, source voltage and the injected current are shown once the system transients die out. It can be seen that the source and midpoint voltages are phase aligned, while the injected current is lagging these two voltages by 90° . Furthermore, the midpoint voltage magnitude is tightly regulated. Fig. 10.8 (b) depicts the perturbation in the load angle and the injected reactive power. It can be seen that the load angle undergoes sustained oscillation and this oscillation is in phase with the

injected reactive power. This implies that, by tightly regulating the midpoint voltage through a high gain integral controller, the injected reactive power oscillates in sympathy with the rotor angle. Therefore to damp out the rotor oscillation, a controller must be designed such that the injected reactive power is in phase opposition with the load angle. It is to be noted that the source voltage also modulates in sympathy with the injected reactive power. This however is not evident from Fig. 10.8 (a) as the time axis has been shortened here.

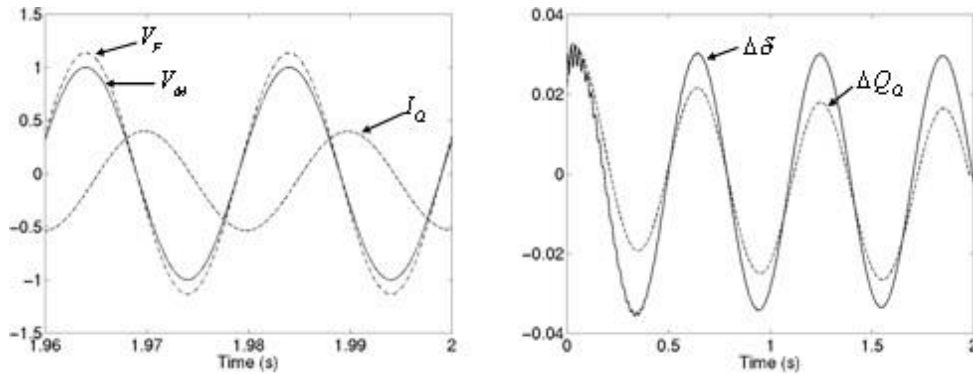

Fig. 10.8 Sustained oscillation in rotor angle due to strong regulation of midpoint voltage.

To improve damping, we now introduce a term that is proportional to the deviation of machine speed in the feedback loop such that the control law is given by

$$|V_F| = K_P(1 - |V_M|) + K_I \int (1 - |V_M|) dt + C_P \frac{d\Delta\delta}{dt} \quad (10.19)$$

The values of proportional gain K_P and integral gain K_I chosen are same as before, while the value of C_P chosen is 50. With the system operating on steady state, delivering power at a load angle of 40° for 50 ms, breaker B (see Fig. 10.7) opens inadvertently. The magnitude of the midpoint voltage is shown in Fig. 10.9 (a). It can be seen that the magnitude settles to the desired value of per unit once the initial transients die down. Fig. 10.9 (b) depicts perturbations in load angle and reactive power injected from their Perrault steady state values. It can be seen that these two quantities have a phase difference of about 90° and this is essential for damping of power oscillations.

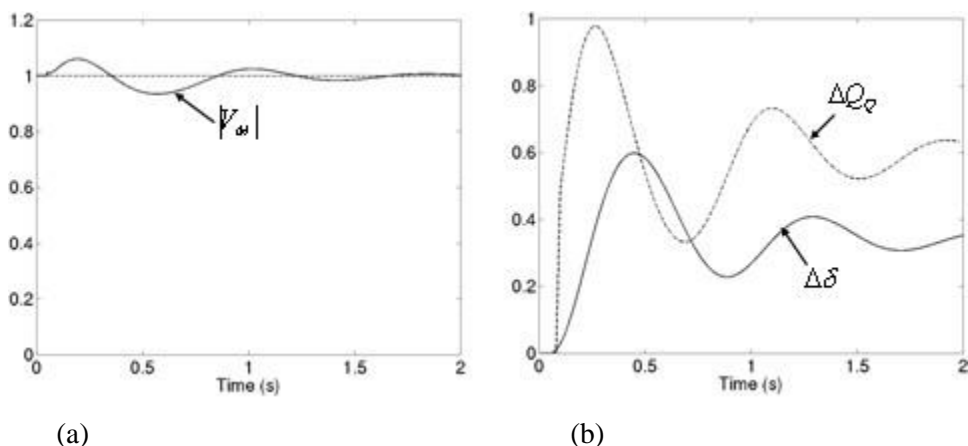

Fig 10.9 System response with the damping controller

Section II: Ideal Series Compensator

- Impact of Series Compensator on Voltage Profile
- Improving Power-Angle Characteristics
- An Alternate Method of Voltage Injection
- Improving Stability Margin
- Comparisons of the Two Modes of Operation
- Power Flow Control and Power Swing Damping

Ideal Series Compensator

Let us assume that the series compensator is represented by an ideal voltage source. This is shown in Fig.

Let us further assume that the series compensator is ideal, i.e., it only supplies reactive power and no real power to the system. It is needless to say that this assumption is not valid for practical systems. However, for an introduction, the assumption is more than adequate. It is to be noted that, unlike the shunt

Compensator, the location of the series compensator is not crucial, and it can be placed anywhere along the transmission line.

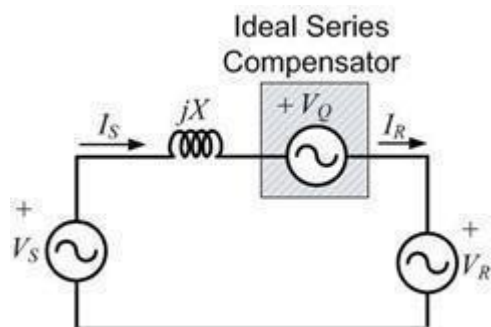

Fig. 10.10 Schematic diagram of an ideal series compensated system.

Impact of Series Compensator on Voltage Profile

In the equivalent schematic diagram of a series compensated power system is shown in Fig. 10.10, the receiving end current is equal to the sending end current, i.e., $I_S = I_R$. The series voltage V_Q is injected in such a way that the magnitude of the injected voltage is made proportional to that of the line current.

Furthermore, the phase of the voltage is forced to be in quadrature with the line current. We then have

$$V_Q = \lambda I_S e^{\mp j90^\circ} \quad (10.20)$$

The ratio λ/X is called the **compensation level** and is often expressed in percentage. This compensation level is usually measured with respect to the transmission line reactance. For example, we shall refer the compensation level as 50% when $\lambda = X/2$. In the analysis presented below, we assume that the injected voltage lags the line current. The implication of the voltage leading the current will be discussed later.

Applying KVL we get

$$V_S - V_Q - V_R = jXI_S \Rightarrow V_S - V_R = \mp j\lambda I_S + jXI_S$$

$$I_S = \frac{V \angle \delta - V}{j(X \mp \lambda)} \quad (10.21)$$

Assuming $V_S = V \angle \delta$ and $V_R = V \angle 0^\circ$, we get the following expression for the line current

When we choose $V_Q = \lambda I_S e^{-j90^\circ}$, the line current equation becomes

$$I_S = \frac{V \angle \delta - V}{j(X - \lambda)}$$

Thus we see that λ is subtracted from X . This choice of the sign corresponds to the voltage source acting as a pure capacitor. Hence we call this as the **capacitive mode of operation**

In contrast, if we choose $V_Q = \lambda I_S e^{+j90^\circ}$, λ is added to X , and this mode is referred to as the **inductive mode of operation**. Since this voltage injection using (10.20) add λ to or subtract λ from the line reactance, we shall refer it as voltage injection in **constant reactance mode**. We shall consider the implication of series voltage injection on the transmission line voltage through the following example.

Example 10.3

Consider a lossless transmission line that has a 0.5 per unit line reactance (X). The sending end and receiving end voltages are given by $1 \angle \delta$ and $1 \angle 0^\circ$ per unit respectively where δ is chosen as 30° . Let

us choose $\lambda = 0.5$ and operation in the capacitive mode. For this line, this implies a 30% level of line impedance compensation. The line current is then given from (10.21) as $I_S = 1.4797 \angle -15^\circ$ per unit and the injected voltage calculated from (10.20) is $V_Q = 0.2218 \angle -75^\circ$ per unit. The phasor diagrams of the two end voltages, line current and injected voltage are shown in Fig. 10.11 (a). We shall now consider a few different cases.

Let us assume that the series compensator is placed in the middle of the transmission line. We then define two voltages, one at either side of the series compensator. These are:

Voltage on the left: $V_{QL} = V_S - jXI_S / 2 = 0.9723 \angle -8.45^\circ$ per unit

on the right: $V_{QR} = V_R + jXI_S / 2 = 0.9723 \angle 21.55^\circ$ per unit

The difference of these two voltages is the **injected voltage**. This is shown in Fig. 10.11 (b), where the angle $\theta = 8.45^\circ$. The worst case voltage along the line will then be at the two points on either side of the series compensator where the voltage phasors are aligned with the line current phasor. These two points are equidistant from the series compensator. However, their particular locations will be dependent on the system parameters.

As a second case, let us consider that the series compensator is placed at the end of the transmission line, just before the infinite bus. We then have the following voltage

Voltage on the left of the compensator: $V_{QL} = V_R + V_Q = 1.0789 \angle -11.46^\circ$ per unit

This is shown in Fig. 10.11 (c). The maximum voltage rise in the line is then to the immediate left of the compensator, i.e., at V_{QL} . The maximum voltage drop however still occurs at the point where the voltage phasor is aligned with the line current phasor.

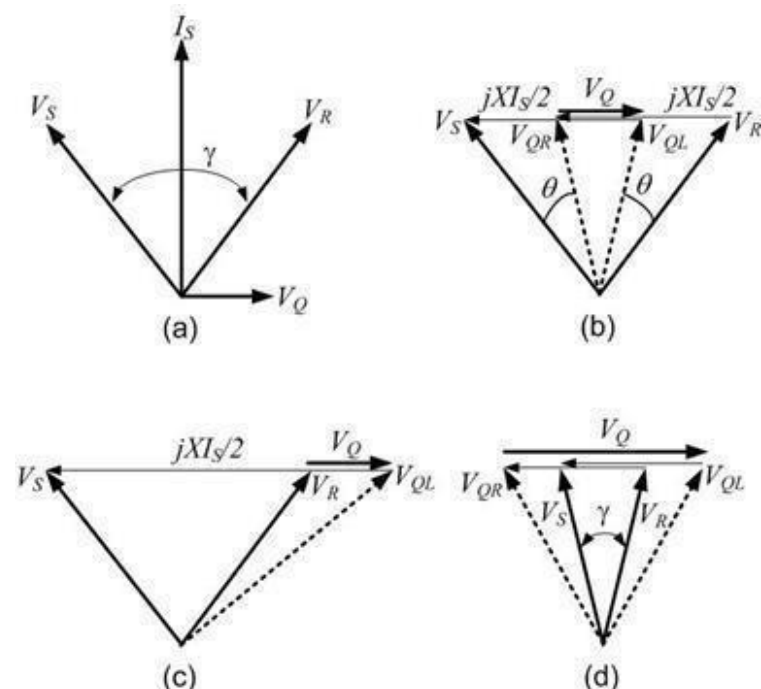

As a third case, let us increase the level of compensation from 30% to 70% (i.e., change λ from 0.15 to 0.35). We however, do not want to change the level of steady state power transfer. The relation between power transfer and compensation level will be discussed in the next subsection. It will however suffice to say that this is accomplished by lowering the value of the angle δ of the sending end voltage to 12.37° . Let us further assume that the series compensator is placed in the middle of the transmission line. We then have $V_{QL} = 1.0255 < -8.01^\circ$ per unit and $V_{QR} = 1.0255 < 20.38^\circ$ per unit. This is shown in Fig. 10.11 (d). It is obvious that the voltage along the line rises to a maximum level at either side of the series compensator.

Improving Power-Angle Characteristics

$$\begin{aligned} P_s + jQ_s &= V_s I_s^* = V \angle \delta \left[\frac{V \angle -\delta - V}{-j(X \mp \lambda)} \right] = \frac{V^2 - V^2 \angle \delta}{-j(X \mp \lambda)} \\ &= \frac{V^2 \sin \delta}{X \mp \lambda} + j \frac{V^2(1 - \cos \delta)}{X \mp \lambda} \end{aligned} \quad (10.22)$$

Noting that the sending end apparent power is $V_s I_s^*$, we can write Similarly the receiving end apparent power is given by

$$\begin{aligned} P_r + jQ_r &= V_r I_s^* = V \left[\frac{V \angle -\delta - V}{-j(X \mp \lambda)} \right] \\ &= \frac{V^2 \sin \delta}{X \mp \lambda} + j \frac{V^2(\cos \delta - 1)}{X \mp \lambda} \end{aligned} \quad (10.23)$$

$$P_s = P_r = P_e = \frac{V^2}{X \mp \lambda} \sin \delta \quad (10.24)$$

Hence the real power transmitted over the line is given by

The power-angle characteristics of a series compensated power system are given in Fig. 10.12. In this figure the base power is chosen as V^2 / X . Three curves are shown, of which the curve P_0 is the **power-angle curve** when the line is not compensated. Curves which have maximum powers greater than the base power pertain to capacitive mode of operation. On the other hand, all curves the inductive mode of operation will have maximum values less than 1. For example, in Fig. 10.12, the curve P_1 is for capacitive mode and the curve P_2 is for inductive mode of operation.

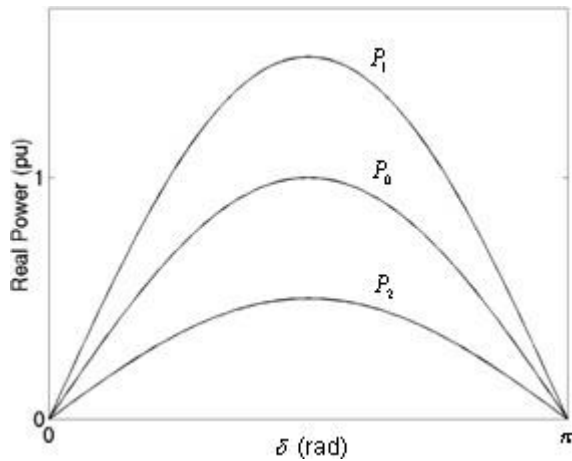

Fig. 10.12 Power-angle characteristics in constant reactance mode.

Let us now have a look at the reactive power. For simplicity let us restrict our attention to capacitive mode of operation only as this represents the normal mode of operation in which the power transfer over the line is enhanced. From (10.20) and (10.21) we get the reactive power supplied by the compensator as

$$Q_{\theta} = V_{\theta} I_s^* = -j\lambda \frac{V \angle \delta - V}{j(X - \lambda)} \times \frac{V \angle -\delta - V}{-j(X - \lambda)}$$

Solving the above equation we get

$$Q_{\theta} = -j \frac{2\lambda V^2}{(X - \lambda)^2} (1 - \cos \delta) \quad (10.25)$$

In Fig. 10.13, the reactive power injected by the series compensator is plotted against the maximum power transfer as the compensation level changes from 10% to 60%. As the compensation level increases, the maximum power transfer also increases. However, at the same time, the reactive injection requirement from the series compensator also increases. It is interesting to note that at 50% compensation level, the reactive power injection requirement from a series compensator is same that from shunt compensator that is regulating the midpoint voltage to 1.0 per unit.

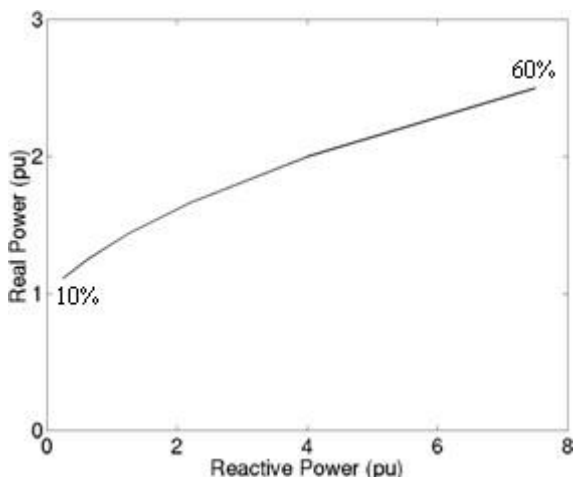

Fig. 10.13 Reactive power injection by a series compensator versus maximum power transfer as the level of compensation changes in constant reactance mode.

An Alternate Method of Voltage Injection

So far we have assumed that the series compensator injects a voltage that is in quadrature with the line current and its magnitude is proportional to the magnitude of the line current. A set of very interesting equations can be obtained if the last assumption about the magnitude is relaxed. The injected voltage is then given by

$$V_{\varrho} = \lambda \frac{\vec{I}_s}{|I_s|} e^{\mp j90^{\circ}} \tag{10.26}$$

We can then write the above equation as

$$\frac{V_{\varrho}}{I_s} = \frac{\lambda}{|I_s|} e^{\mp j90^{\circ}} = \mp j X_{\varrho} \tag{10.27}$$

., the voltage source in quadrature with the current is represented as a pure reactance that is either inductive or capacitive. Since in this form we injected a constant voltage in quadrature with the line current, we shall refer this as **constant voltage injection mode**.

$$X_{eq} = X \mp X_{\varrho}$$

The total equivalent inductance of the line is then

$$P_e = \frac{V^2}{X_{eq}} \sin \delta = \frac{V^2}{X(1 \mp X_{\rho}/X)} \sin \delta$$

Defining $V_S = V < \delta$ and $V_R < 0^\circ$, we can then write the power transfer equation as

$$P_e = \frac{V^2}{X(1 \mp |V_{\rho}|/|I_S|X)} \sin \delta$$

Since $|V_{\rho}|/|I_S| = X_{\rho}$, we can modify the above equation as Consider the phasor diagram of Fig. 10.14 (a), which is for capacitive operation of the series compensator. From this diagram we get

$$|I_S|X = |V_{\rho}| + 2V \sin(\delta/2)$$

$$|I_S|X = -|V_{\rho}| + 2V \sin(\delta/2)$$

Similarly from the inductive operation phasor diagram shown in Fig. 10.14 (b), we get

$$\begin{aligned} P_e &= \frac{V^2}{X} \sin \delta \frac{|I_S|X}{|I_S|X \mp |V_{\rho}|} = \frac{V^2}{X} \sin \delta \frac{\pm |V_{\rho}| + 2V \sin(\delta/2)}{\pm |V_{\rho}| + 2V \sin(\delta/2) \mp |V_{\rho}|} \\ &= \frac{V^2}{X} \sin \delta \frac{\pm |V_{\rho}| + 2V \sin(\delta/2)}{2V \sin(\delta/2)} = \frac{V^2}{X} \sin \delta \pm \frac{V}{X} |V_{\rho}| \cos(\delta/2) \end{aligned} \quad (10.29)$$

Substituting the above two equations in (10.28) and rearranging we get where the positive sign is for capacitive operation

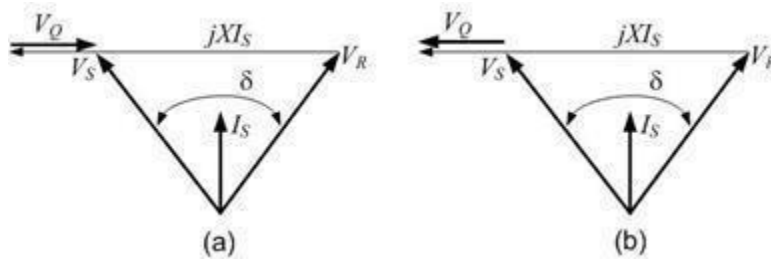

Fig. 10.14 Phasor diagram of series compensated system: (a) capacitive operation and (b) inductive operation.

The power-angle characteristics of this particular series connection are given in Fig. 10.15. In this figure the base power is chosen as V^2/X . Three curves are shown, of which the curve P_0 is the **power-angle curve** when the line is not compensated. Curves which have maximum powers greater than the base power pertain to capacitive mode of operation. On the other hand, all curves the inductive mode of operation will have maximum values less than 1. For example, in Fig. 10.15, the curve P_1 is for capacitive mode and the curve P_2 is for inductive mode of operation.

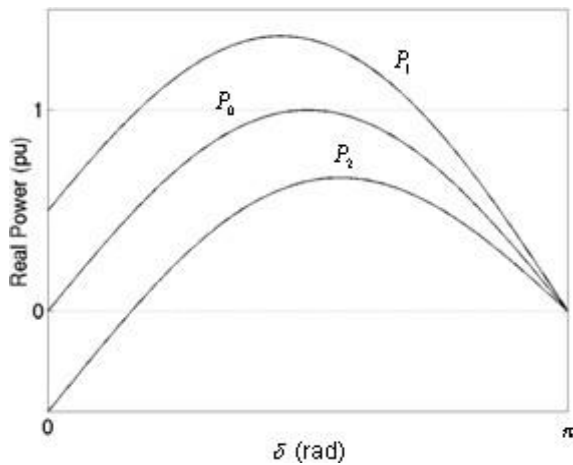

Fig. 10.15 Power-angle characteristics for constant voltage mode

$$Q_D = |V_D| |I_s| \quad (10.30)$$

The reactive power supplied by the compensator in this case will be

Improving Stability Margin

From the power-angle curves of Figs. 10.13 and 10.15 it can be seen that the same amount of power can be transmitted over a capacitive compensated line at a lower load angle than an uncompensated system. Furthermore, an increase in the height in the power-angle curve means that a larger amount of decelerating area is available for a compensated system. Thus improvement in stability margin for a capacitive series compensated system over an uncompensated system is obvious.

Comparisons of the Two Modes of Operation

As a comparison between the two different modes of voltage injection, let us first consider the constant reactance mode of voltage injection with a compensation level of 50%. Choosing V^2 / X as the base power, the power-angle characteristic reaches a maximum of 2.0 per unit at a load angle $\pi / 2$. Now $|V_Q|$ in constant voltage mode is chosen such that the real power is 2.0 per unit at a load angle of $\pi / 2$. This is accomplished using (10.29) where we get

$$|V_Q| = \frac{2 - \sin 90^\circ}{\cos 45^\circ} = 1.4142 \quad \text{Per unit}$$

The power-angle characteristics of the two different modes are now drawn in Fig. 10.16 (a). It can be seen that the two curves match at $\pi / 2$. However, the maximum power for constant voltage case is about 2.1 per unit and occurs at an angle of 67° .

Fig. 10.16 (b) depicts the line current for the two cases. It can be seen that the increase in line current in either case is monotonic. This is not surprising for the case of constant reactance mode since as the load

angle increases, both real power and line currents increase. Now consider the case of constant voltage control. When the load angle moves backwards from $\pi/2$ to 67° , the power moves from 2.0 per unit to its peak value of 2.1 per unit. The line current during this stage decreases from about 2.83 to 2.50 per unit. Thus, even though the power through the line increases, the line current decreases.

Power Flow Control and Power Swing Damping

One of the major advantages of series compensation is that through its use real power flow over transmission corridors can be effectively controlled. Consider, for example, the SMIB system shown in Fig. 10.17 in which the generator and infinite bus are connected through a double circuit transmission line, labeled line-1 and line-2. Of the two transmission lines, line-2 is compensated by a series compensator. The compensator then can be utilized to regulate power flow over the entire system.

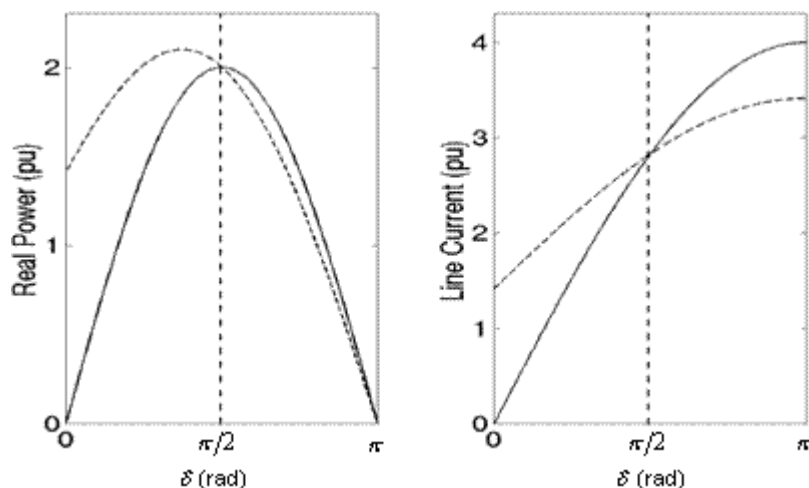

Fig. 10.16 Power-angle and line current-angle characteristics of the two different methods of voltage injection: solid line showing constant reactance mode and dashed line showing constant voltage mode.

For example, let us consider that the system is operating in the steady state delivering a power of P_{m0} at a load angle of δ_0 . Lines 1 and 2 are then sending power P_{e1} and P_{e2} respectively, such that $P_{m0} = P_{e1} + P_{e2}$. The mechanical power input suddenly goes up to P_{m1} . There are two ways of controlling the power in this situation:

- **Regulating Control:** Channeling the increase in power through line-1. In this case the series compensator maintains the power flow over line-2 at P_{e2} . The load angle in this case goes up in sympathy with the increase in P_{e1} .
- **Tracking Control:** Channeling the increase in power through line-2. In this case the series compensator helps in maintaining the power flow over line-1 at P_{e1} while holding the load angle to δ_0 .

Let us illustrate these two aspects with the help of a numerical example.

Example 10.4

Let us consider the system of Fig. 7.8 where the system parameters are given by

System Frequency = 50 Hz, $|V_S| = |V_R| = 1.0$ per unit, $X = 0.5$ per unit and $d_0 = 30^\circ$

It is assumed that the series compensator operates in constant reactance mode with a compensation level of 30%. We then have

$P_{e1} = 1.0$ per unit, $P_{e2} = 1.43$ per unit, $P_m = 2.43$ per unit

The objective of the control scheme here is to maintain the power through line-2 to a pre-specified value, P_{ref} . To accomplish this a proportional-plus-integral (PI) controller is placed in the feedback loop of P_{e2} . In addition, to improve damping a term that is proportional to the deviation of machine speed is introduced in the feedback loop. The control law is then given by

$$C_L = K_P (P_{ref} - P_{e2}) + K_I \int (P_{ref} - P_{e2}) dt + C_P \frac{d\Delta\delta}{dt} \quad (10.31)$$

Where $C_L = \lambda / X$ is the compensation level. For the simulation studies performed, the following controller parameters are chosen

$K_P = 0.1$, $K_I = 1.0$ and $C_P = 75$

Regulating Control: With the system operating in the nominal steady state, the mechanical power input is suddenly raised by 10%. It is expected that the series compensator will hold the power through line-2 constant at line-2 at P_{e2} such that entire power increase is channeled through line-1. We then expect that the power P_{e1} will increase to 1.243 per unit and the load angle to go up to 0.67 rad. The compensation level will then change to 13%.

The time responses for various quantities for this test are given in Fig. 10.18. In Fig. 10.18 (a), the power through the two line is plotted. It can be seen that while the power through line-2 comes back to its nominal value following the transient, the power through the other line is raised to expected level. Similarly, the load angle and the compensation level reach their expected values, as shown in Figs. 10.18

(b) and (c), respectively. Finally, Fig. 10.18 (d) depicts the last two cycles of phase-a of the line current and injected voltage. It can be clearly seen that these two quantities are in quadrature, with the line current leading the injected voltage.

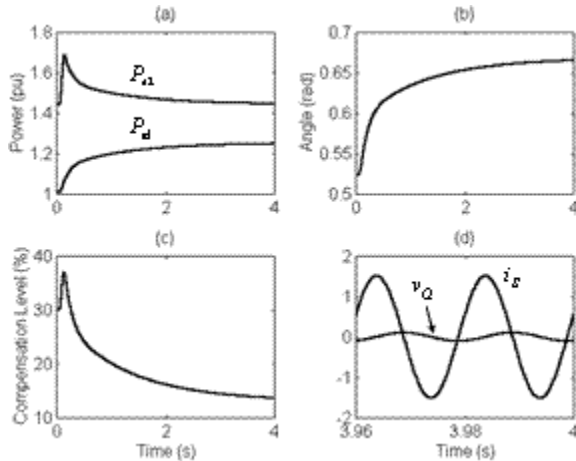

Fig. 10.18 System response with regulating power flow controller Tracking Control

With the system operating in the nominal steady state, the mechanical power input is suddenly raised by 25%. It is expected that the series compensator will make the entire power increase to flow through line-2 such that both P_{e1} and load angle are maintained constant at their nominal values. The power P_{e2} through line-2 will then increase to about 2.04 per unit and the compensation level will change to 51%.

The time responses for various quantities for this test are given in Fig. 10.19. It can be seen that while the power through line-1 comes back to its nominal value following the transient, the power through the other line is raised to level expected. Similarly, the load angle comes back to its nominal value and the compensation level is raised 51%, as shown in Figs. 10.19 (b) and (c), respectively. Finally, Fig. 7.19 (d) depicts the last two cycles of phase-a of the line current and injected voltage.

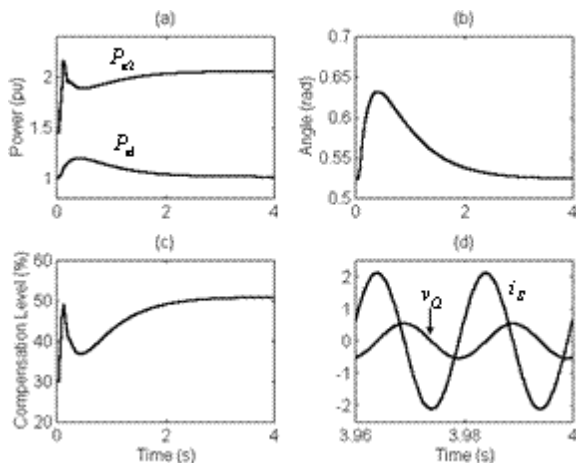

Fig. 10.19 System response with regulating power flow controller