

POWER ELECTRONICS

The control of electric motor drives requires control of electric power. Power electronics have eased the concept of power control. Power electronics signifies the word power electronics and control or we can say the electronic that deal with power equipment for power control.

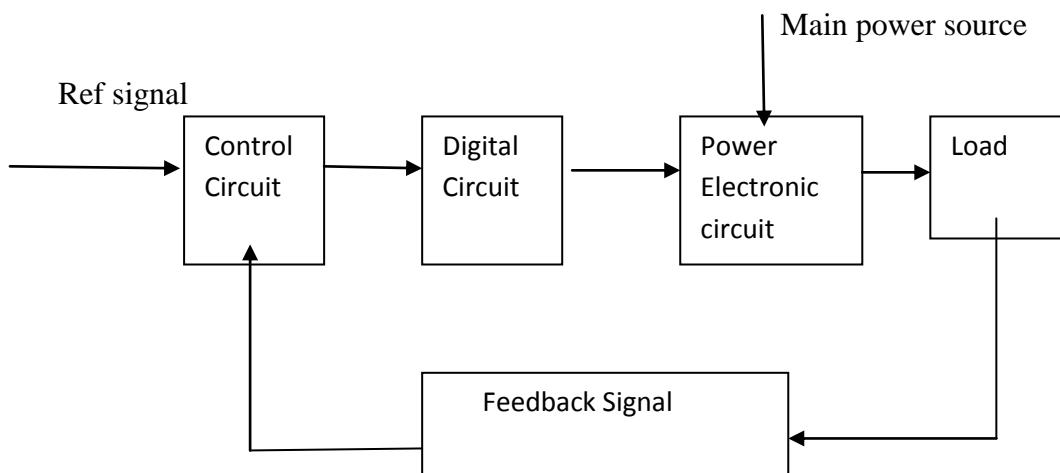

Power electronics based on the switching of power semiconductor devices. With the development of power semiconductor technology, the power handling capabilities and switching speed of power devices have been improved tremendously.

Power Semiconductor Devices

The first SCR was developed in late 1957. Power semiconductor devices are broadly categorized into 3 types:

1. Power diodes (600V,4500A)
2. Transistors
3. Thyristors (10KV,300A,30MW)

Thyristor is a four layer three junction pnpn semiconductor switching device. It has 3 terminals these are anode, cathode and gate. SCRs are solid state device, so they are compact, possess high reliability and have low loss.

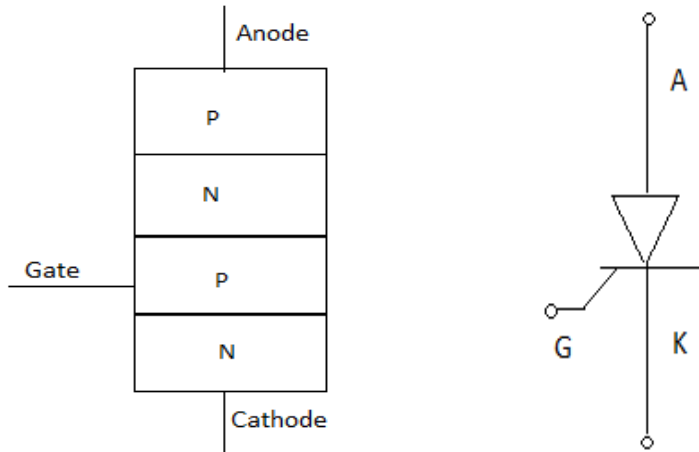

SCR is made up of silicon, it act as a rectifier; it has very low resistance in the forward direction and high resistance in the reverse direction. It is a unidirectional device.

Static V-I characteristics of a Thyristor

The circuit diagram for obtaining static V-I characteristics is as shown

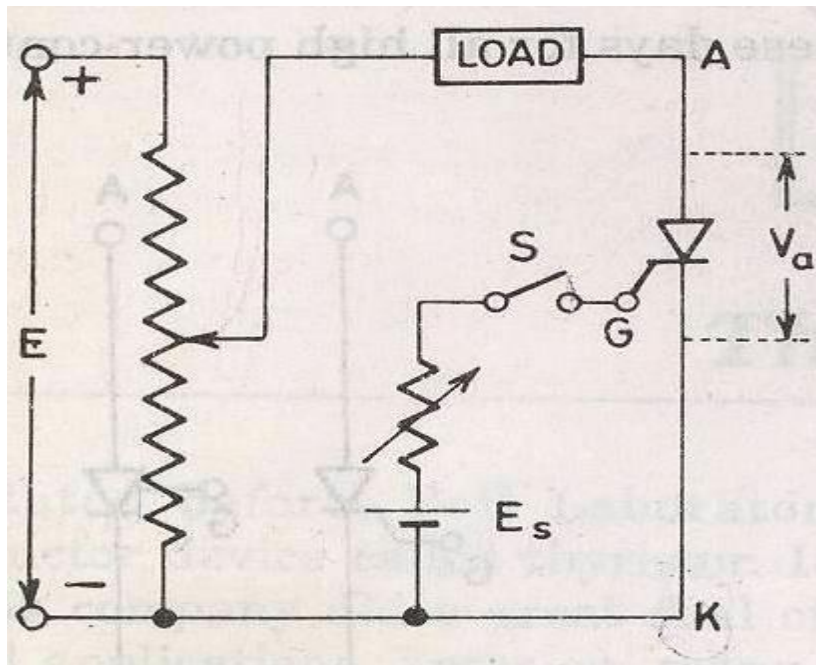

Anode and cathode are connected to main source voltage through the load. The gate and cathode are fed from source E_s .

A typical SCR V-I characteristic is as shown below:

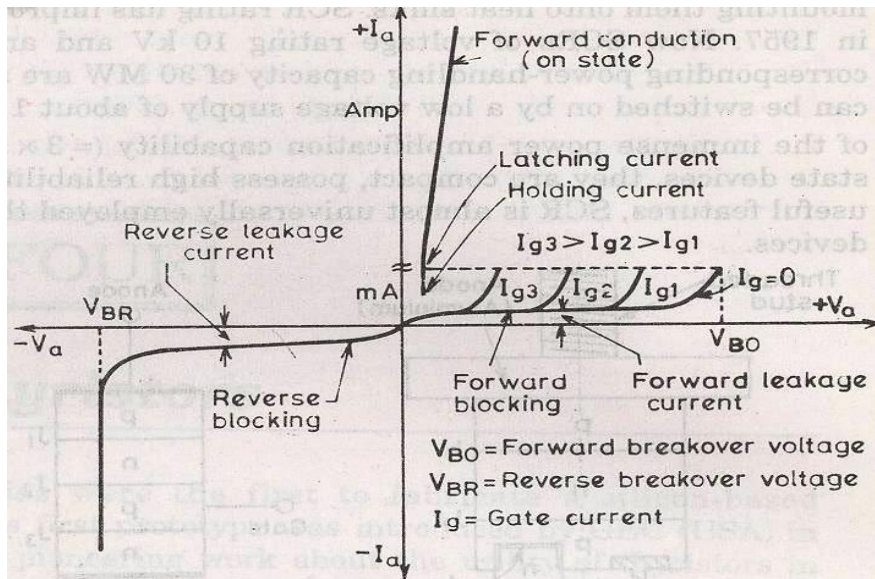

V_{BO} = Forward breakover voltage

V_{BR} = Reverse breakover voltage

I_g = Gate current

V_a = Anode voltage across the thyristor terminal A, K.

I_a = Anode current

It can be inferred from the static V-I characteristic of SCR. SCR have 3 modes of operation:

1. Reverse blocking mode
2. Forward blocking mode (off state)
3. Forward conduction mode (on state)

1. Reverse Blocking Mode

When cathode of the thyristor is made positive with respect to anode with switch open thyristor is reverse biased. Junctions J_1 and J_2 are reverse biased where junction J_2 is forward biased. The device behaves as if two diodes are connected in series with reverse voltage applied across them.

- A small leakage current of the order of few mA only flows. As the thyristor is reverse biased and in blocking mode. It is called as acting in reverse blocking mode of operation.
- Now if the reverse voltage is increased, at a critical breakdown level called reverse breakdown voltage V_{BR} , an avalanche occurs at J_1 and J_3 and the reverse

current increases rapidly. As a large current associated with V_{BR} and hence more losses to the SCR.

This results in Thyristor damage as junction temperature may exceed its maximum temperature rise.

2. Forward Blocking Mode

When anode is positive with respect to cathode, with gate circuit open, thyristor is said to be forward biased.

Thus junction J_1 and J_3 are forward biased and J_2 is reverse biased. As the forward voltage is increases junction J_2 will have an avalanche breakdown at a voltage called forward breakover voltage V_{BO} . When forward voltage is less than V_{BO} thyristor offers high impedance. Thus a thyristor acts as an open switch in forward blocking mode.

3. Forward Conduction Mode

Here thyristor conducts current from anode to cathode with a very small voltage drop across it. So a thyristor can be brought from forward blocking mode to forward conducting mode:

1. By exceeding the forward breakover voltage.
2. By applying a gate pulse between gate and cathode.

During forward conduction mode of operation thyristor is in on state and behave like a close switch. Voltage drop is of the order of 1 to 2mV. This small voltage drop is due to ohmic drop across the four layers of the device.

Different turn ON methods for SCR

1. Forward voltage triggering
2. Gate triggering
3. $\frac{dv}{dt}$ triggering
4. Light triggering
5. Temperature triggering

1. Forward voltage triggering

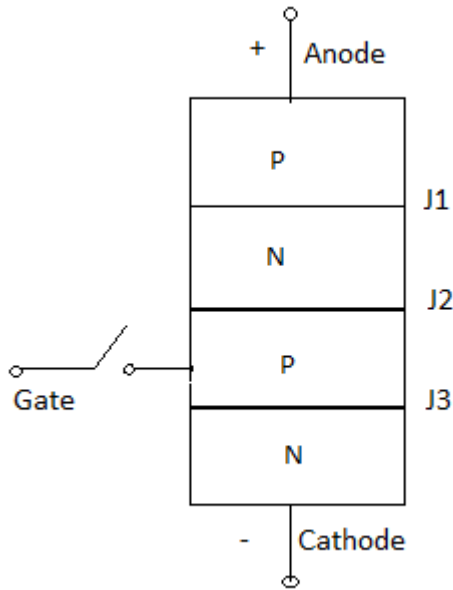

A forward voltage is applied between anode and cathode with gate circuit open.

- Junction J_1 and J_3 is forward biased.
- Junction J_2 is reverse biased.
- As the anode to cathode voltage is increased breakdown of the reverse biased junction J_2 occurs. This is known as avalanche breakdown and the voltage at which this phenomena occurs is called forward breakover voltage.
- The conduction of current continues even if the anode cathode voltage reduces below V_{BO} till I_a will not go below I_h . Where I_h is the holding current for the thyristor.

2. Gate triggering

This is the simplest, reliable and efficient method of firing the forward biased SCRs. First SCR is forward biased. Then a positive gate voltage is applied between gate and cathode. In practice the transition from OFF state to ON state by exceeding V_{BO} is never employed as it may destroy the device. The magnitude of V_{BO} , so forward breakover voltage is taken as final voltage rating of the device during the design of SCR application.

First step is to choose a thyristor with forward breakover voltage (say 800V) higher than the normal working voltage. The benefit is that the thyristor will be in blocking state with normal working voltage applied across the anode and cathode with gate open. When we require the turning ON of a SCR a positive gate voltage between gate and cathode is applied. The point to be noted that cathode n-layer is heavily doped as compared to gate p-layer. So when gate supply is given between gate and cathode gate p-layer is flooded with electron from cathode n-layer. Now the thyristor is forward biased, so some of these electron reach junction J_2 . As a result width of J_2 breaks down or conduction at J_2 occur at a voltage less than V_{BO} . As I_g increases V_{BO} reduces which decreases then turn ON time. Another important point is duration for which the gate current is applied should be more then turn ON time. This means

that if the gate current is reduced to zero before the anode current reaches a minimum value known as holding current, SCR can't turn ON.

In this process power loss is less and also low applied voltage is required for triggering.

3. dv/dt triggering

This is a turning ON method but it may lead to destruction of SCR and so it must be avoided.

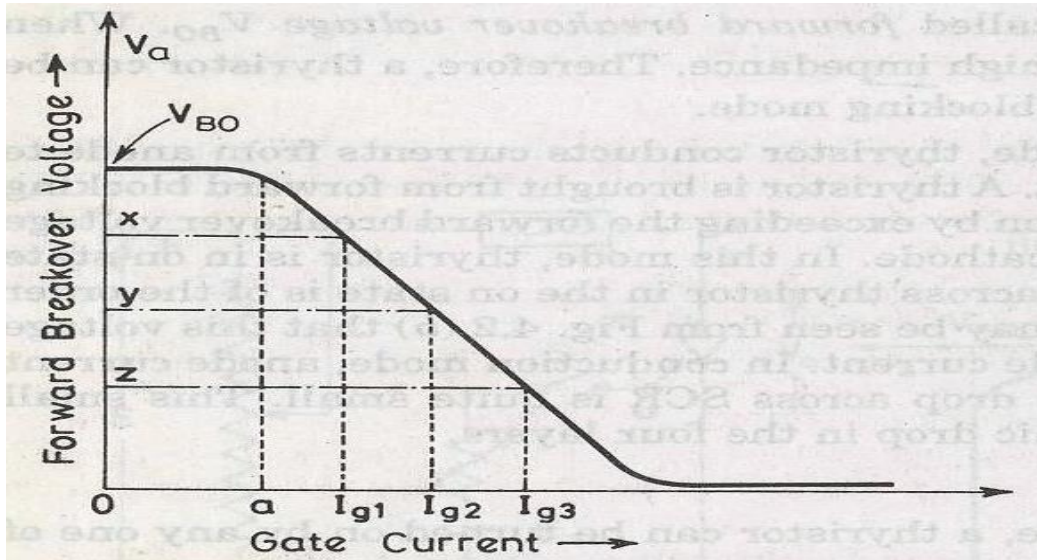

When SCR is forward biased, junction J_1 and J_3 are forward biased and junction J_2 is reverse biased so it behaves as if an insulator is placed between two conducting plates. Here J_1 and J_3 act as a conducting plate and J_2 acts as an insulator. J_2 is known as junction capacitor. So if we increase the rate of change of forward voltage instead of increasing the magnitude of voltage, junction J_2 breaks and starts conducting. A high value of changing current may damage the SCR. So SCR may be protected from high $\frac{dv}{dt}$.

$$q = cv$$

$$I_a = c \frac{dv}{dt}$$

$$I_a \propto \frac{dv}{dt}$$

4. Temperature triggering

During forward bias, J_2 is reverse biased so a leakage forward current is always associated with SCR. Now as we know the leakage current is temperature dependent, so if we increase the temperature the leakage current will also increase and heat dissipation of junction J_2 occurs. When this heat reaches a sufficient value J_2 will break and conduction starts.

Disadvantages

This type of triggering causes local hot spot and may cause thermal run away of the device.

This triggering cannot be controlled easily.

It is very costly as protection is costly.

5. Light triggering

First a new recess niche is made in the inner p-layer. When this recess is irradiated, then free charge carriers (electron and hole) are generated. Now if the intensity is increased above a certain value then it leads to turn ON of SCR. Such SCR are known as Light activated SCR (LASCR).

Some definitions:

Latching current

The latching current may be defined as the minimum value of anode current which at must attain during turn ON process to maintain conduction even if gate signal is removed.

Holding current

It is the minimum value of anode current below which if it falls, the SCR will turn OFF.

Switching characteristics of thyristors

The time variation of voltage across the thyristor and current through it during turn on and turn off process gives the dynamic or switching characteristic of SCR.

Switching characteristic during turn on

Turn on time

It is the time during which it changes from forward blocking state to ON state. Total turn on time is divided into 3 intervals:

1. Delay time
2. Rise time
3. Spread time

Delay time

If I_g and I_a represent the final value of gate current and anode current. Then the delay time can be explained as time during which the gate current attains $0.9 I_g$ to the instant anode current reaches $0.1 I_g$ or the anode current rises from forward leakage current to $0.1 I_a$.

1. Gate current $0.9 I_g$ to $0.1 I_a$.
2. Anode voltage falls from V_a to $0.9V_a$.
3. Anode current rises from forward leakage current to $0.1 I_a$.

Rise time (t_r)

Time during which

1. Anode current rises from $0.1 I_a$ to $0.9 I_a$
2. Forward blocking voltage falls from $0.9V_a$ to $0.1V_a$. V_a is the initial forward blocking voltage.

Spread time (t_p)

1. Time taken by the anode current to rise from $0.9I_a$ to I_a .
2. Time for the forward voltage to fall from $0.1V_o$ to on state voltage drop of 1 to 1.5V. During turn on, SCR is considered to be a charge controlled device. A certain amount of charge is injected in the gate region to begin conduction. So higher the magnitude of gate current it requires less time to inject the charges. Thus turn on time is reduced by using large magnitude of gate current.

How the distribution of charge occurs?

As the gate current begins to flow from gate to cathode with the application of gate signal. Gate current has a non uniform distribution of current density over the cathode surface. Distribution of current density is much higher near the gate. The density decrease as the distance from the gate increases. So anode current flows in a narrow region near gate where gate current densities are highest. From the beginning of rise time the anode current starts spreading itself. The anode current spread at a rate of 0.1mm/sec. The spreading anode current requires some time if the rise time is not sufficient then the anode current cannot spread over the entire region of cathode. Now a large anode current is applied and also a large anode current flowing through the SCR. As a result turn on losses is high. As these losses occur over a small conducting region so local hot spots may form and it may damage the device.

Switching Characteristics During Turn Off

Thyristor turn off means it changed from ON to OFF state. Once thyristor is ON there is no role of gate. As we know thyristor can be made turn OFF by reducing the anode current below the latching current. Here we assume the latching current to be zero ampere. If a forward voltage is applied across the SCR at the moment it reaches zero then SCR will not be able to block this forward voltage. Because the charges trapped in the 4-layer are still favourable for conduction and it may turn on the device. So to avoid such a case, SCR is reverse biased for some time even if the anode current has reached to zero.

So now the turn off time can be different as the instant anode current becomes zero to the instant when SCR regains its forward blocking capability.

$$t_q = t_{rr} + t_{qr}$$

Where,

t_q is the turn off time, t_{rr} is the reverse recovery time, t_{gr} is the gate recovery time

At t_1 anode current is zero. Now anode current builds up in reverse direction with same $\frac{dv}{dt}$ slope. This is due to the presence of charge carriers in the four layers. The reverse recovery current removes the excess carriers from J_1 and J_3 between the instants t_1 and t_3 . At instant t_3 the end junction J_1 and J_3 is recovered. But J_2 still has trapped charges which decay due to recombination only so the reverse voltage has to be maintained for some more time. The time taken for the recombination of charges between t_3 and t_4 is called gate recovery time t_{gr} . Junction J_2 recovered and now a forward voltage can be applied across SCR.

The turn off time is affected by:

1. Junction temperature
2. Magnitude of forward current $\frac{di}{dt}$ during commutation.

Turn off time decreases with the increase of magnitude of reverse applied voltage.

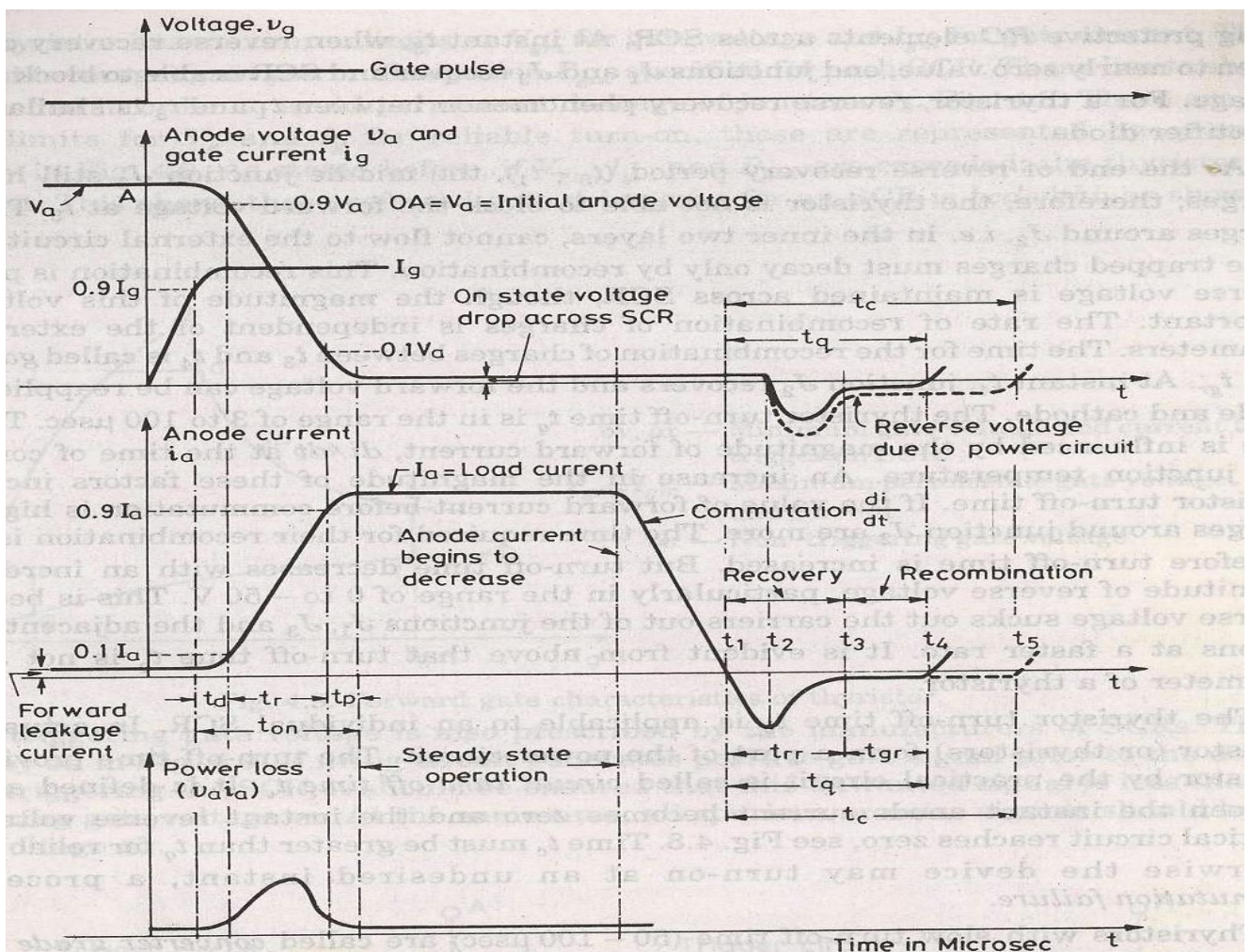

GTO(Gate turn off thyristor)

A gate turn off thyristor is a pnpn device. In which it can be turned ON like an ordinary SCR by a positive gate current. However it can be easily turned off by a negative gate pulse of appropriate magnitude.

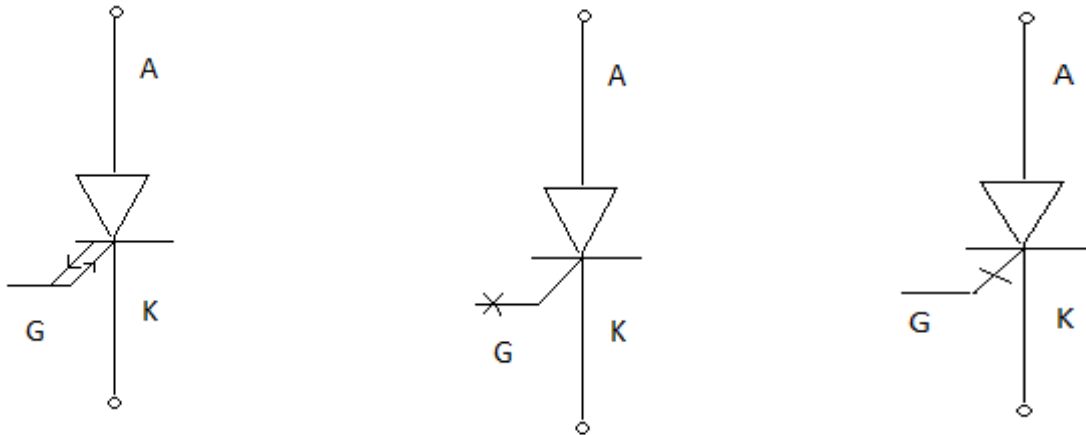

Conventional SCR are turned on by a positive gate signal but once the SCR is turned on gate loses control over it. So to turn it off we require external commutation circuit. These commutation circuits are bulky and costly. So due to these drawbacks GTO comes into existence.

The salient features of GTO are:

1. GTO turned on like conventional SCR and is turned off by a negative gate signal of sufficient magnitude.
2. It is a non latching device.
3. GTO reduces acoustic and electromagnetic noise.

It has high switching frequency and efficiency.

A gate turn off thyristor can turn on like an ordinary thyristor but it is turn off by negative gate pulse of appropriate magnitude.

Disadvantage

The negative gate current required to turn off a GTO is quite large that is 20% to 30 % of anode current

Advantage

It is compact and cost less

Switching performance

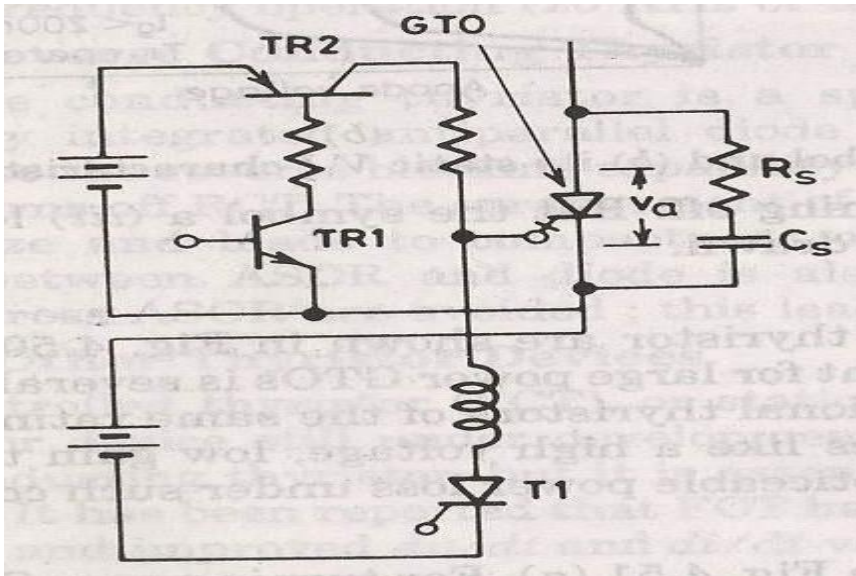

1. For turning ON a GTO first TR1 is turned on.
2. This in turn switches on TR2 so that a positive gate current pulse is applied to turn on the GTO.
3. Thyristor T_1 is used to apply a high peak negative gate current pulse.

Gate turn-on characteristics

1. The gate turn on characteristics is similar to a thyristor. Total turn on time consists of delay time, rise time, spread time.
2. The turn on time can be reduced by increasing its forward gate current.

GATE TURN OFF

Turn off time is different for SCR. Turn off characteristics is divided into 3 pd

1. Storage time
2. Fall time
3. Tail time

$$T_q = t_s + t_f + t_t$$

At normal operating condition gto carries a steady state current. The turn off process starts as soon as negative current is applied after $t=0$.

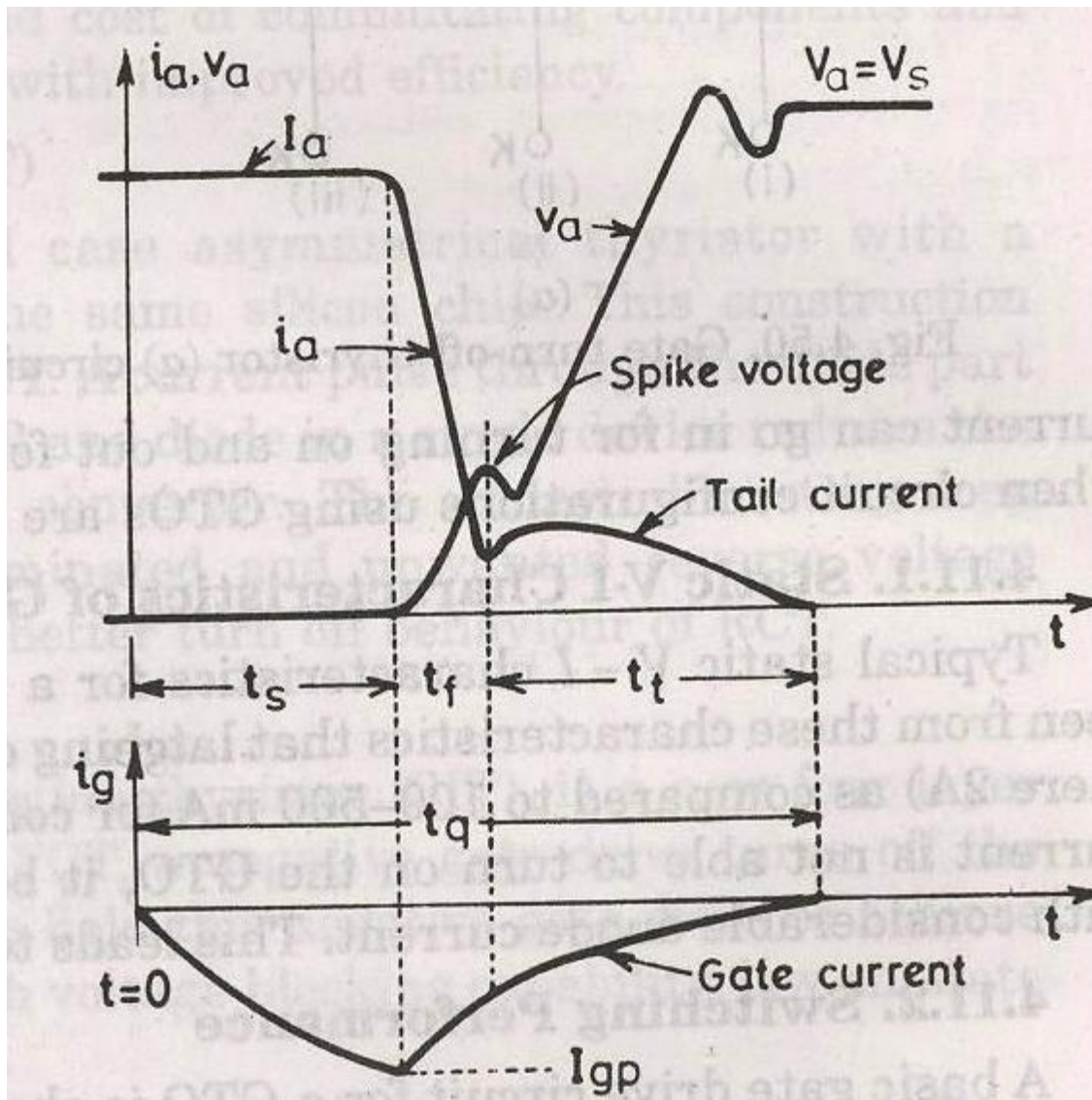

STORAGE TIME

During the storage pd the anode voltage and current remains constant. The gate current rises depending upon the gate circuit impedance and gate applied voltage. The beginning of pd is as soon as negative gate current is applied. The end of storage pd is marked by fall in anode current and rise in voltage, what we have to do is remove the excess carriers. The excess carriers are removed by negative carriers.

FALL TIME

After t_s , anode current begins to fall rapidly and anode voltage starts rising. After falling to a certain value, then anode current changes its rate to fall. This time is called fall time.

SPIKE IN VOLTAGE

During the time of storage and fall time there is a change in voltage due to abrupt current change.

TAIL TIME

During this time, the anode current and voltage continues towards the turn off values. The transient overshoot is due to the snubber parameter and voltage stabilizes to steady state value.

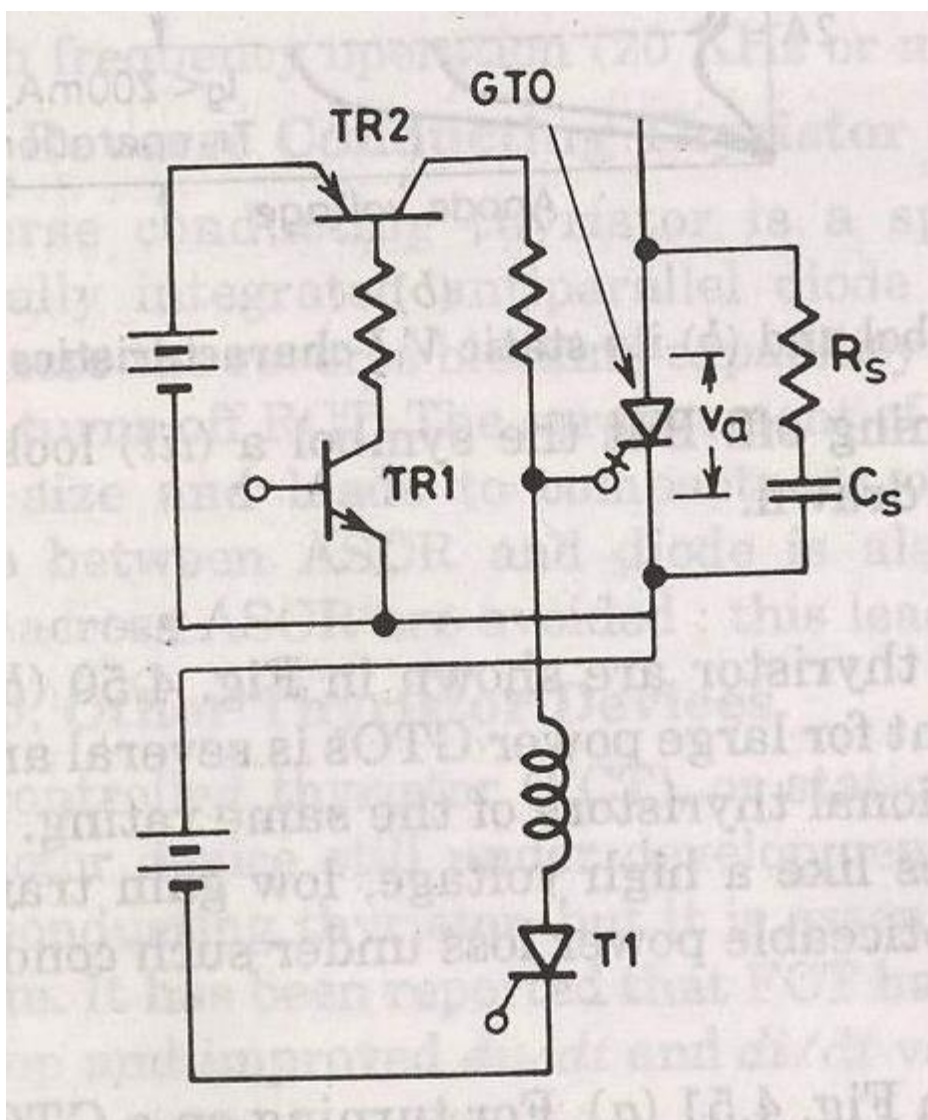

THE TRIAC

As SCR is a unidirectional device, the conduction is from anode to cathode and not from cathode to anode. It conducts in both directions. It is a bidirectional SCR with three terminals.

TRIAC=TRIODE+AC

Here it is considered to be two SCRS connected in anti parallel. As it conducts in both directions so it is named as MT1, MT2 and gate G.

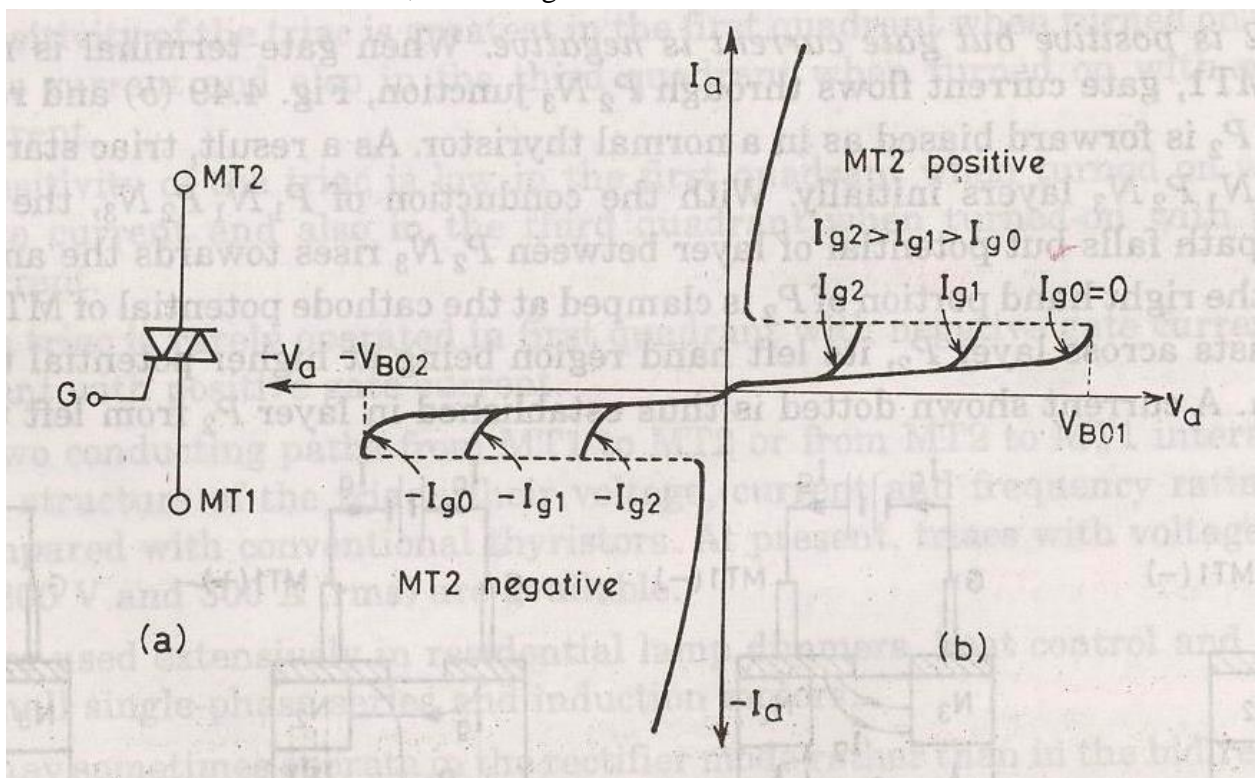

SALIENT FEATURES

1. Bi directional triode thyristor
2. TRIAC means triode that works on ac
3. It conducts in both directions
4. It is a controlled device

5. Its operation is similar to two diodes connected in anti parallel with common gate connection.

6. It has 3 terminals MT1, MT2 and gate G

Its use is control of power in ac.

POWER BJT

Power BJT means a large voltage blocking in the OFF state and high current carrying capability in the ON state. In most power application, base is the input terminal. Emitter is the common terminal. Collector is the output terminal.

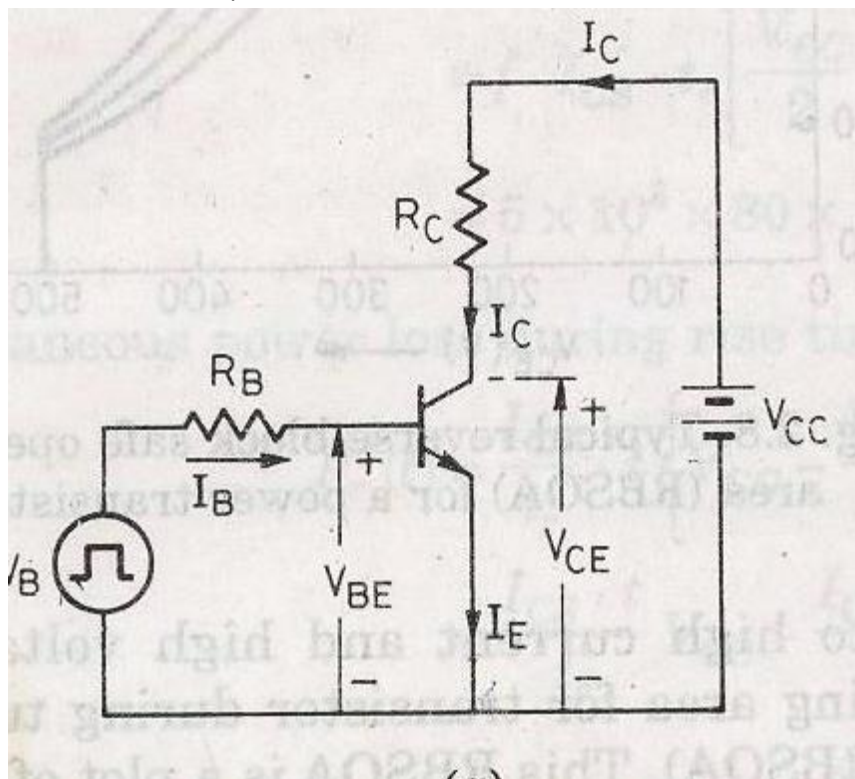

SIGNAL LEVEL OF BJT

n^+ doped emitter layer, doping of base is more than collector. Depletion layer exists more towards the collector than emitter

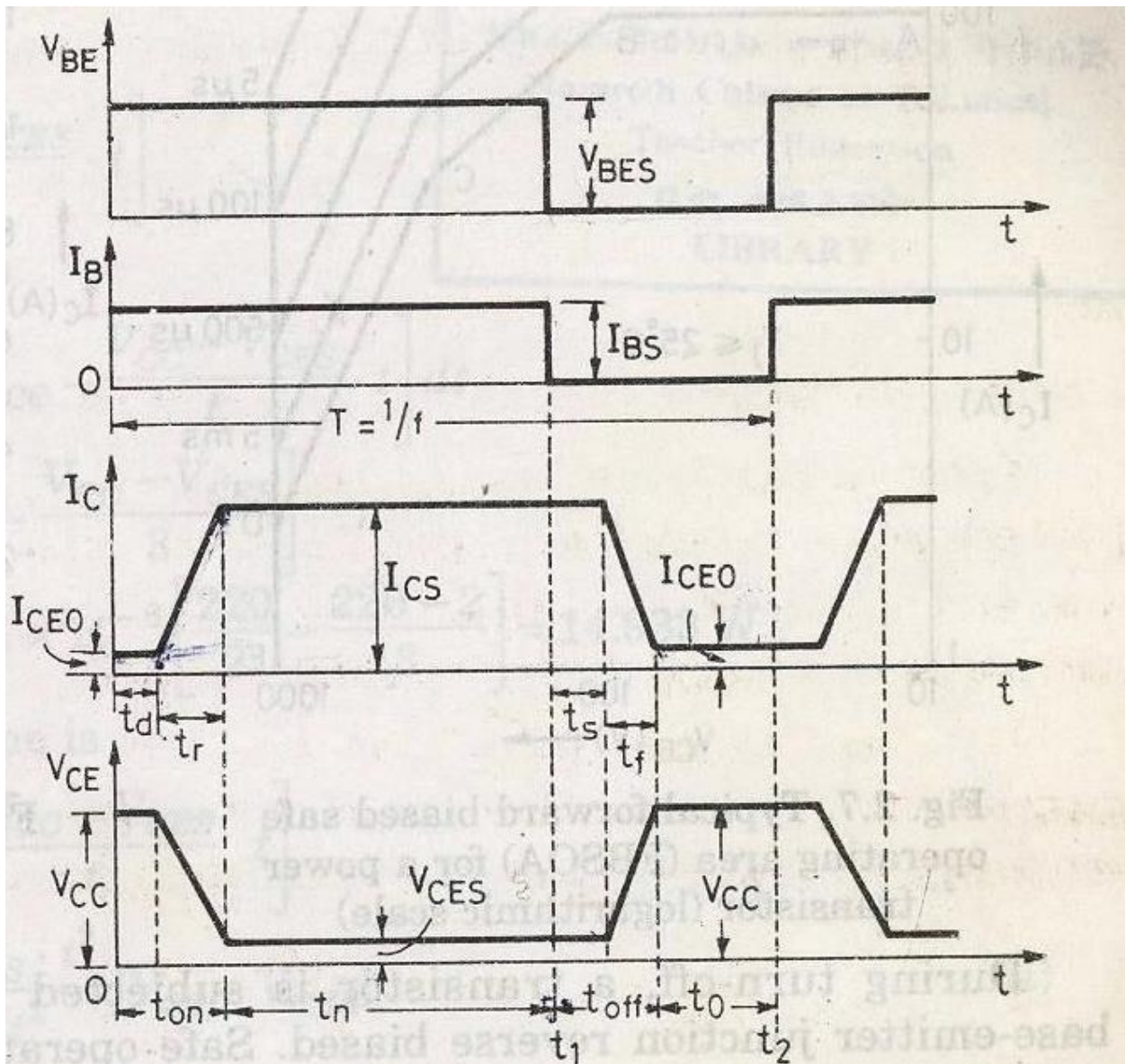

POWER BJT CONSTRUCTION

The maximum collector-emitter voltage that can be sustained across the junction, when it is carrying substantial collector current.

V_{ce0} = maximum collector and emitter voltage that can be sustained by the device.

V_{cbo} = collector-base breakdown voltage with emitter open

PRIMARY BREAKDOWN

It is due to conventional avalanche breakdown of the C-B junction and its associated large flow of current. The thickness of the depletion region determines the breakdown voltage of the transistor. The base thickness is made as small as possible, in order to have good amplification capability. If the thickness is too small, the breakdown voltage is compromised. So a compromise has to be made between the two.

THE DOPING LEVELS-

- 1.The doping of the emitter layer is quite large.
- 2.The base doping is moderate.
- 3.n- region is lightly doped.
- 4.n+ region doping level is similar to emitter.

1.THICKNESS OF DRIFT REGION-

It determines the breakdown length of the transistor.

2.THE BASE THICKNES –

Small base thickness- good amplification capability

Too small base thickness- the breakdown voltage of the transistor has to be compromised.

For a relatively thick base,the current gain will be relatively small.so it is increase the gain.Monolithicsigns for darlington connected BJT pair have been developed.

SECONDARY BREAKDOWN

Secondary breakdown is due to large power dissipation at localized site within the semiconductor.

PHYSICS OF BJT OPERATION-

The transistor is assumed to operate in active region. There is no doped collector drift region. It has importance only in switching operation, in active region of operation.

B-E junction is forward biased and C-B junction is reverse biased. Electrons are injected into base from the emitter. Holes are injected from base into the emitter.

QUASI SATURATION-

Initially we assume that, the transistor is in active region. Base current is allowed to increase then let's see what happens.first collector rises in response to base current.So there is a increase voltage drop across the collector load.So C-E voltage drops.

Because of increase in collector current, there is a increase in voltage in drift region. This eventually reduces the reverse biased across the C-B junction.so n-p junction get smaller, at some point the junction become forward biased. So now injection of holes from base into collector drift region occurs. Charge neutrality requires the electron to be injected in the drift region of the holes. From where these electron came. Since a large no of electron is supplied to the C-B junction via injection from emitter and subsequent diffusion across the base. As excess carrier build up in the drift region begins to occur quasi saturation region is entered.

Gate Triggering Methods

Types

The different methods of gate triggering are the following

- R-triggering.
- RC triggering.
- UJT triggering.

Resistance Triggering

A simple resistance triggering circuit is as shown. The resistor R_1 limits the current through the gate of the SCR. R_2 is the variable resistance added to the circuit to achieve control over the triggering angle of SCR. Resistor 'R' is a stabilizing resistor. The diode D is required to ensure that no negative voltage reaches the gate of the SCR.

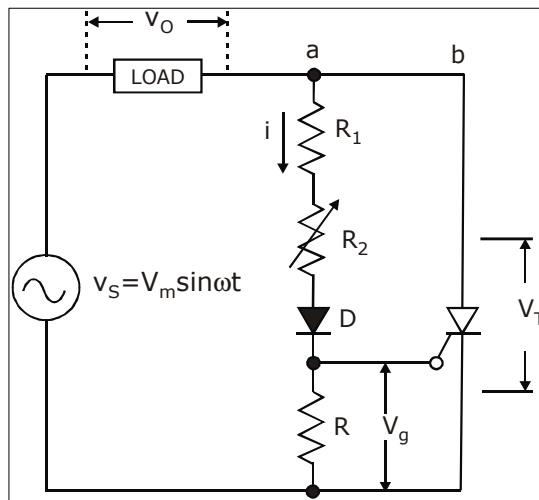

Fig: Resistance firing circuit

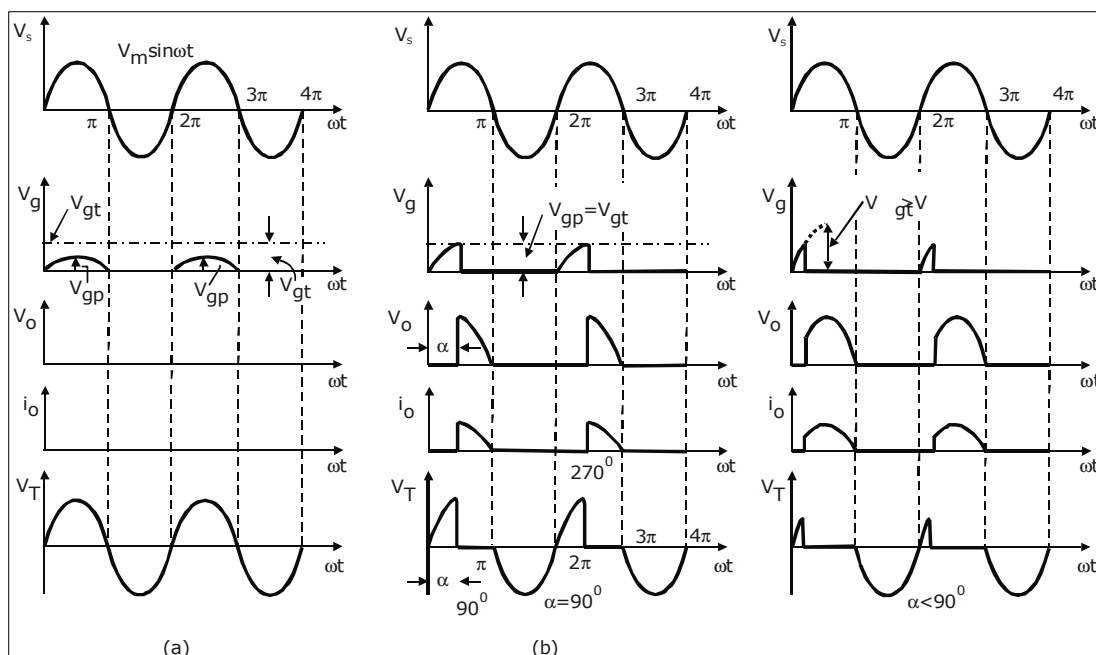

Fig. Resistance firing of an SCR in half wave circuit with dc load

(a) No triggering of SCR (b) $\alpha = 90^\circ$ (c) $\alpha < 90^\circ$

Design

With $R_2 = 0$, we need to ensure that $\frac{V_m}{R_1} < I_{gm}$, where I_{gm} is the maximum or peak gate current of the SCR. Therefore $R_1 \geq \frac{V_m}{I_{gm}}$.

Also with $R_2 = 0$, we need to ensure that the voltage drop across resistor 'R' does not exceed V_{gm} , the maximum gate voltage

$$\begin{aligned} V_{gm} &\geq \frac{V_m R}{R_1 + R} \\ \therefore V_{gm} R_1 + V_{gm} R &\geq V_m R \\ \therefore V_{gm} R_1 &\geq R(V_m - V_{gm}) \\ R &\leq \frac{V_{gm} R_1}{V_m - V_{gm}} \end{aligned}$$

Operation

Case 1: $V_{gp} < V_{gt}$

V_{gp} , the peak gate voltage is less than V_{gt} since R_2 is very large. Therefore, current 'I' flowing through the gate is very small. SCR will not turn on and therefore the load voltage is zero and v_{scr} is equal to V_s . This is because we are using only a resistive network. Therefore, output will be in phase with input.

Case 2: $V_{gp} = V_{gt}$, $R_2 \rightarrow$ optimum value.

When R_2 is set to an optimum value such that $V_{gp} = V_{gt}$, we see that the SCR is triggered at 90° (since V_{gp} reaches its peak at 90° only). The waveforms show that the load voltage is zero till 90° and the voltage across the SCR is the same as input voltage till it is triggered at 90° .

Case 3: $V_{gp} > V_{gt}$, $R_2 \rightarrow$ small value.

The triggering value V_{gt} is reached much earlier than 90° . Hence the SCR turns on earlier than V_s reaches its peak value. The waveforms as shown with respect to $V_s = V_m \sin \omega t$.

At $\omega t = \alpha, V_s = V_{gt}, V_m = V_{gp} (\because V_{gt} = V_{gp} \sin \alpha)$

Therefore
$$\alpha = \sin^{-1} \left(\frac{V_{gt}}{V_{gp}} \right)$$

But
$$V_{gp} = \frac{V_m R}{R_1 + R_2 + R}$$

Therefore
$$\alpha = \sin^{-1} \left[\frac{V_{gt} (R_1 + R_2 + R)}{V_m R} \right]$$

Since V_{gt}, R_1, R are constants

Resistance Capacitance Triggering

A. RC Half Wave

Capacitor 'C' in the circuit is connected to shift the phase of the gate voltage. D_1 is used to prevent negative voltage from reaching the gate cathode of SCR.

In the negative half cycle, the capacitor charges to the peak negative voltage of the supply ($-V_m$) through the diode D_2 . The capacitor maintains this voltage across it, till the supply voltage crosses zero. As the supply becomes positive, the capacitor charges through resistor 'R' from initial voltage of $-V_m$, to a positive value.

When the capacitor voltage is equal to the gate trigger voltage of the SCR, the SCR is fired and the capacitor voltage is clamped to a small positive value.

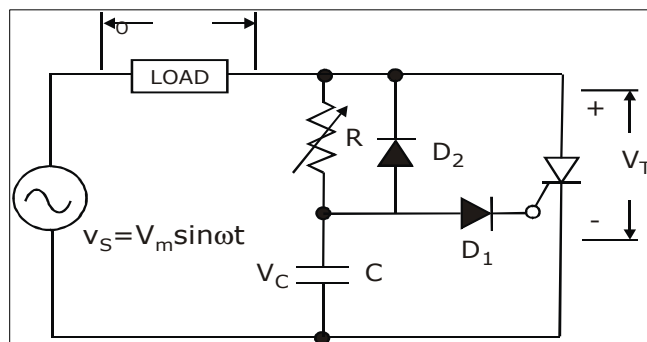

Fig.: RC half-wave trigger circuit

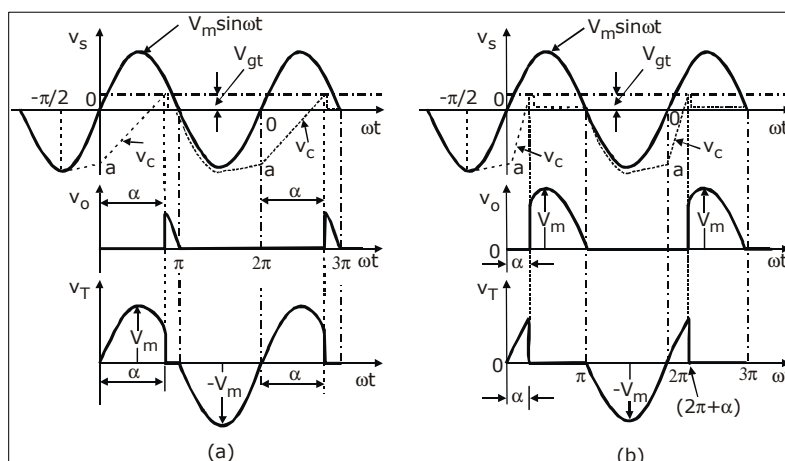

Fig: Waveforms for RC half-wave trigger circuit

(a) High value of R (b) Low value of R

Case 1: R → Large.

When the resistor ‘R’ is large, the time taken for the capacitance to charge from $-V_m$ to V_{gt} is large, resulting in larger firing angle and lower load voltage.

Case 2: R → Small

When ‘R’ is set to a smaller value, the capacitor charges at a faster rate towards V_{gt} resulting in early triggering of SCR and hence V_L is more. When the SCR triggers, the voltage drop across it falls to 1 – 1.5V. This in turn lowers, the voltage across R & C. Low voltage across the SCR during conduction period keeps the capacitor discharge during the positive half cycle.

Design Equation

From the circuit $V_C = V_{gt} + V_{d1}$. Considering the source voltage and the gate circuit, we can write $v_s = I_{gt}R + V_C$. SCR fires when $v_s \geq I_{gt}R + V_C$ that is $v_s \geq I_{gt}R + V_{gt} + V_{d1}$. Therefore $R \leq \frac{v_s - V_{gt} - V_{d1}}{I_{gt}}$. The RC time constant for zero output voltage that is maximum firing angle

for power frequencies is empirically gives as $RC \geq 1.3 \left(\frac{T}{2} \right)$.

B. RC Full Wave

A simple circuit giving full wave output is shown in figure below. In this circuit the initial voltage from which the capacitor ‘C’ charges is essentially zero. The capacitor ‘C’ is reset to this voltage by the clamping action of the thyristor gate. For this reason the charging time constant RC must be chosen longer than for half wave RC circuit in order to delay the triggering. The RC value is empirically chosen as $RC \geq \frac{50T}{2}$. Also $R \leq \frac{v_s - V_{gt}}{I_{gt}}$.

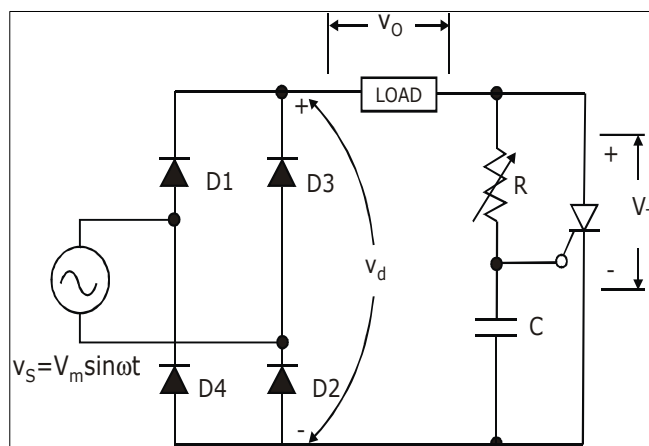

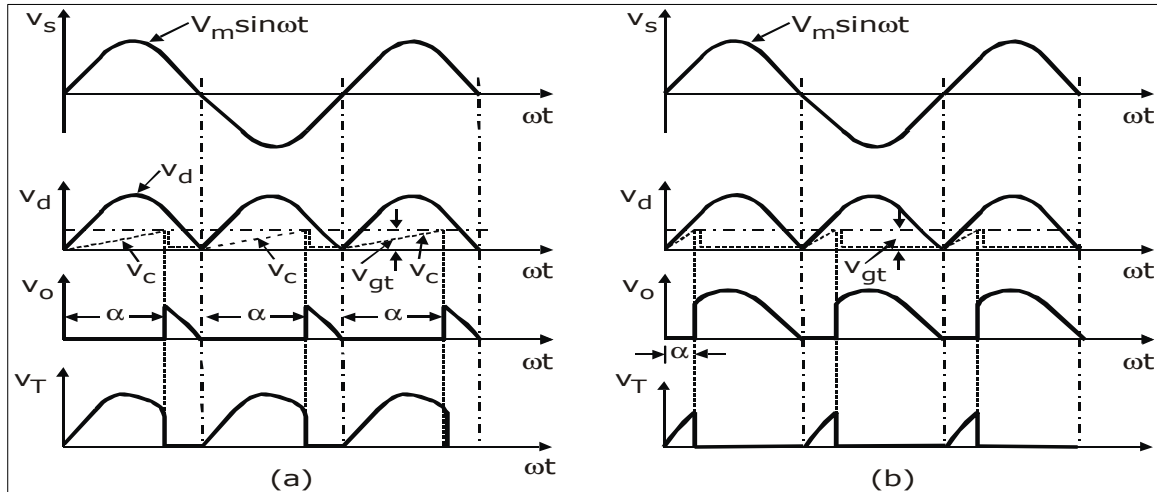

Fig : RC full-wave trigger circuit Fig: Wave-forms for RC full-wave trigger circuit

(a) High value of R

(b) Low value of R

PROBLEM

1. Design a suitable RC triggering circuit for a thyristorised network operation on a 220V, 50Hz supply. The specifications of SCR are $V_{gt\min} = 5V$, $I_{gt\max} = 30mA$.

$$R = \frac{v_s - V_{gt} - V_D}{I_g} = 7143.3\Omega$$

Therefore $RC \geq 0.013$

$R \leq 7.143k\Omega$

$C \geq 1.8199 F$

UNI-JUNCTION TRANSISTOR (UJT)

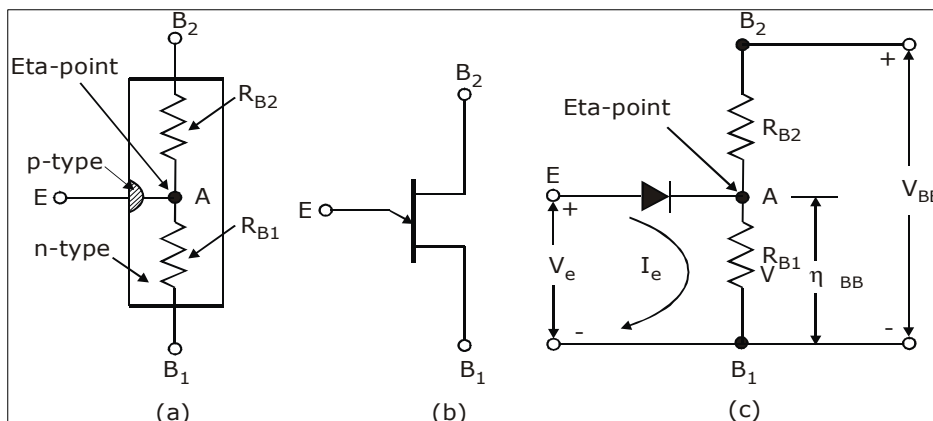

Fig. Basic structure of UJT (b) Symbolic representation

(c) Equivalent circuit

UJT is an n-type silicon bar in which p-type emitter is embedded. It has three terminals base1, base2 and emitter 'E'. Between B_1 and B_2 UJT behaves like ordinary resistor and the internal resistances are given as R_{B1} and R_{B2} with emitter open $R_{BB} = R_{B1} + R_{B2}$. Usually the p-region is heavily doped and n-region is lightly doped. The equivalent circuit of UJT is as shown. When V_{BB} is applied across B_1 and B_2 , we find that potential at A is

$$V_{AB1} = \frac{V_{BB}R_{B1}}{R_{B1} + R_{B2}} = \eta V_{BB} \left[\eta = \frac{R_{B1}}{R_{B1} + R_{B2}} \right]$$

is intrinsic stand off ratio of UJT and ranges between 0.51 and 0.82. Resistor R_{B2} is between 5 to 10K Ω .

Operation

When voltage V_{BB} is applied between emitter 'E' with base 1 B_1 as reference and the emitter voltage V_E is less than $(V_D + \eta V_{BB})$ the UJT does not conduct. $(V_D + \eta V_{BB})$ is designated as V_p which is the value of voltage required to turn on the UJT. Once V_E is equal to $V_p \equiv \eta V_{BB} + V_D$, then UJT is forward biased and it conducts.

The peak point is the point at which peak current I_p flows and the peak voltage V_p is across the UJT. After peak point the current increases but voltage across device drops, this is due to the fact that emitter starts to inject holes into the lower doped n-region. Since p-region is heavily doped compared to n-region. Also holes have a longer life time, therefore number of carriers in the base region increases rapidly. Thus potential at 'A' falls but current I_E increases rapidly. R_{B1} acts as a decreasing resistance.

The negative resistance region of UJT is between peak point and valley point. After valley point, the device acts as a normal diode since the base region is saturated and R_{B1} does not decrease again.

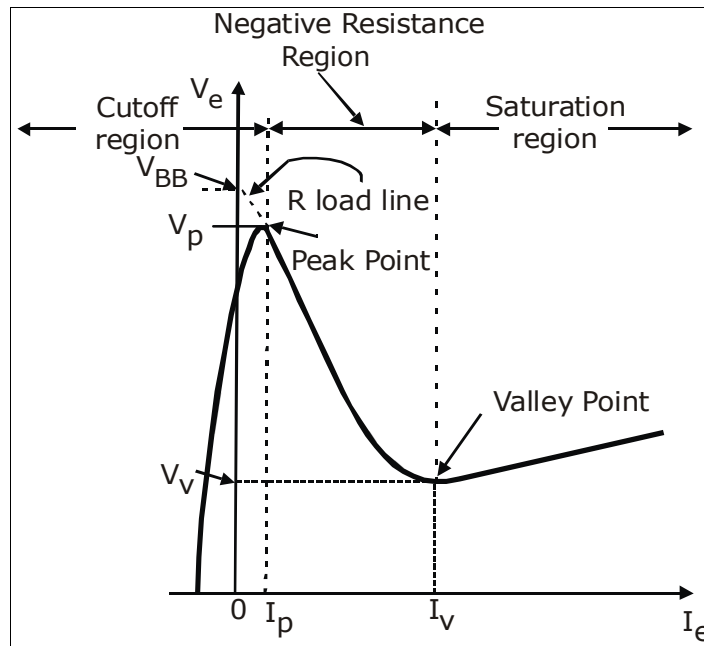

Fig: V-I Characteristics of UJT

3.8 UJT RELAXATION OSCILLATOR

UJT is highly efficient switch. The switching times is in the range of nanoseconds. Since UJT exhibits negative resistance characteristics it can be used as relaxation oscillator. The circuit diagram is as shown with R_1 and R_2 being small compared to R_{B1} and R_{B2} of UJT.

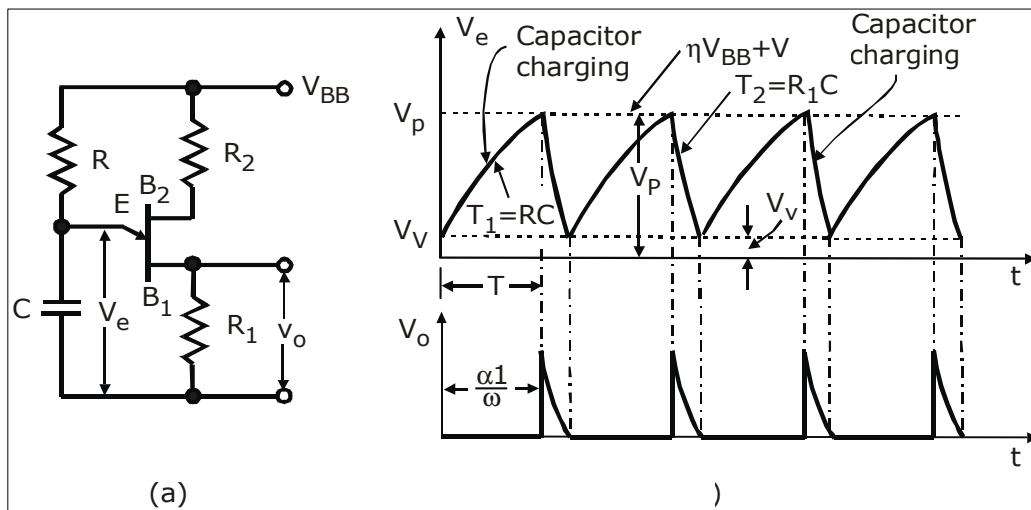

Fig: UJT oscillator (a) Connection diagram and (b) Voltage waveforms

Operation

When V_{BB} is applied, capacitor 'C' begins to charge through resistor 'R' exponentially towards V_{BB} . During this charging emitter circuit of UJT is an open circuit. The rate of charging τ is $T_1 = RC$. When this capacitor voltage which is nothing but emitter voltage V_e

reaches the peak point $V_p = \eta V_{BB} + V_D$, the emitter base junction is forward biased and UJT turns on. Capacitor 'C' rapidly discharges through load resistance R_1 with time constant $\tau_2 = R_1 C$ ($\tau_2 = \tau_1$). When emitter voltage decreases to valley point V_v , UJT turns off. Once again the capacitor will charge towards V_{BB} and the cycle continues. The rate of charging of the capacitor will be determined by the resistor R in the circuit. If R is small the capacitor charges faster towards V_{BB} and thus reaches V_p faster and the SCR is triggered at a smaller firing angle. If R is large the capacitor takes a longer time to charge towards V_p the firing angle is delayed. The waveform for both cases is as shown below.

(i) Expression for period of oscillation 't'

The period of oscillation of the UJT can be derived based on the voltage across the capacitor. Here we assume that the period of charging of the capacitor is lot larger than than the discharging time.

Using initial and final value theorem for voltage across a capacitor, we get

$$V_C = V_{final} + (V_{initial} - V_{final}) e^{-t/RC}$$

$$t = T, V_C = V_p, V_{initial} = V_v, V_{final} = V_{BB}$$

Therefore $V_p = V_{BB} + (V_v - V_{BB}) e^{-T/RC}$

$$\Rightarrow T = RC \log_e \left(\frac{V_{BB} - V_v}{V_{BB} - V_p} \right)$$

If

$$\begin{aligned} V_v &< V_{BB}, \\ T &= RC \ln \left(\frac{V_{BB}}{V_{BB} - V_p} \right) \\ &= RC \ln \left[\frac{1}{1 - \frac{V_p}{V_{BB}}} \right] \end{aligned}$$

But $V_p = \eta V_{BB} + V_D$

If $V_D = V_{BB} \quad V_p = \eta V_{BB}$

Therefore
$$T = RC \ln \left[\frac{1}{1-} \right]$$

Design of UJT Oscillator

Resistor 'R' is limited to a value between 3 kilo ohms and 3 mega ohms. The upper limit on 'R' is set by the requirement that the load line formed by 'R' and V_{BB} intersects the device characteristics to the right of the peak point but to the left of valley point. If the load line fails to pass to the right of the peak point the UJT will not turn on, this condition will be satisfied if $V_{BB} - I_p R > V_p$, therefore $R < \frac{V_{BB} - V_p}{I_p}$.

At the valley point $I_E = I_v$ and $V_E = V_v$, so the condition for the lower limit on 'R' to ensure turn-off is $V_{BB} - I_v R < V_v$, therefore $R > \frac{V_{BB} - V_v}{I_v}$.

The recommended range of supply voltage is from 10 to 35V. the width of the triggering pulse $t_g = R_{B1} C$.

In general R_{B1} is limited to a value of 100 ohm and R_{B2} has a value of 100 ohm or greater and can be approximately determined as $R_{B2} = \frac{10^4}{\eta V_{BB}}$.

PROBLEM

1. A UJT is used to trigger the thyristor whose minimum gate triggering voltage is 6.2V, The UJT ratings are: $\eta = 0.66$, $I_p = 0.5mA$, $I_v = 3mA$, $R_{B1} + R_{B2} = 5k\Omega$, leakage current = 3.2mA, $V_p = 14v$ and $V_v = 1V$. Oscillator frequency is 2kHz and capacitor C = 0.04 μ F. Design the complete circuit.

Solution

$$T = R_c C \ln \left[\frac{1}{1-} \right]$$

Here,

$$T = \frac{1}{f} = \frac{1}{2 \times 10^3}, \text{ since } f = 2kHz \text{ and putting other values,}$$

$$\frac{1}{2 \times 10^3} = R_c \times 0.04 \times 10^{-6} \ln \left(\frac{1}{1-0.66} \right) = 11.6k\Omega$$

The peak voltage is given as, $V_p = V_{BB} + V_D$

Let $V_D = 0.8$, then putting other values,

$$14 = 0.66V_{BB} + 0.8$$

$$V_{BB} = 20V$$

The value of R_2 is given by

$$R_2 = \frac{0.7(R_{B2} + R_{B1})}{\eta V_{BB}}$$

$$R_2 = \frac{0.7(5 \times 10^3)}{0.66 \times 20}$$

$$\therefore R_2 = 265\Omega$$

Value of R_1 can be calculated by the equation

$$V_{BB} = I_{leakage} (R_1 + R_2 + R_{B1} + R_{B2})$$

$$20 = 3.2 \times 10^{-3} (R_1 + 265 + 5000)$$

$$R_1 = 985\Omega$$

The value of $R_{c(max)}$ is given by equation

$$R_{c(max)} = \frac{V_{BB} - V_p}{I_p}$$

$$R_{c(max)} = \frac{20 - 14}{0.5 \times 10^{-3}}$$

$$R_{c(max)} = 12k\Omega$$

Similarly the value of $R_{c(min)}$ is given by equation

$$R_{c(min)} = \frac{V_{BB} - V_v}{I_v}$$

$$R_{c(min)} = \frac{20 - 1}{3 \times 10^{-3}}$$

$$R_{c(min)} = 6.33k\Omega$$

2. Design the UJT triggering circuit for SCR. Given $-V_{BB} = 20V$, $\eta = 0.6$, $I_p = 10 \text{ A}$, $V_v = 2V$, $I_v = 10mA$. The frequency of oscillation is 100Hz. The triggering pulse width should be 50 μs .

THYRISTOR COMMUTATION TECHNIQUES

Introduction

In practice it becomes necessary to turn off a conducting thyristor. (Often thyristors are used as switches to turn on and off power to the load). The process of turning off a conducting thyristor is called commutation. The principle involved is that either the anode should be made negative with respect to cathode (voltage commutation) or the anode current should be reduced below the holding current value (current commutation).

The reverse voltage must be maintained for a time at least equal to the turn-off time of SCR otherwise a reapplication of a positive voltage will cause the thyristor to conduct even without a gate signal. On similar lines the anode current should be held at a value less than the holding current at least for a time equal to turn-off time otherwise the SCR will start conducting if the current in the circuit increases beyond the holding current level even without a gate signal. Commutation circuits have been developed to hasten the turn-off process of Thyristors. The study of commutation techniques helps in understanding the transient phenomena under switching conditions.

The reverse voltage or the small anode current condition must be maintained for a time at least equal to the TURN OFF time of SCR; Otherwise the SCR may again start conducting. The techniques to turn off a SCR can be broadly classified as

- Natural Commutation
- Forced Commutation.

5.1.1 Natural Commutation (CLASS F)

This type of commutation takes place when supply voltage is AC, because a negative voltage will appear across the SCR in the negative half cycle of the supply voltage and the SCR turns off by itself. Hence no special circuits are required to turn off the SCR. That is the reason that this type of commutation is called Natural or Line Commutation. Figure shows the circuit where natural commutation takes place and figure 1.2 shows the related waveforms. t_c is the time offered by the circuit within which the SCR should turn off completely. Thus t_c should be greater than t_q , the turn off time of the SCR. Otherwise, the SCR will become forward biased before it has turned off completely and will start conducting even without a gate signal.

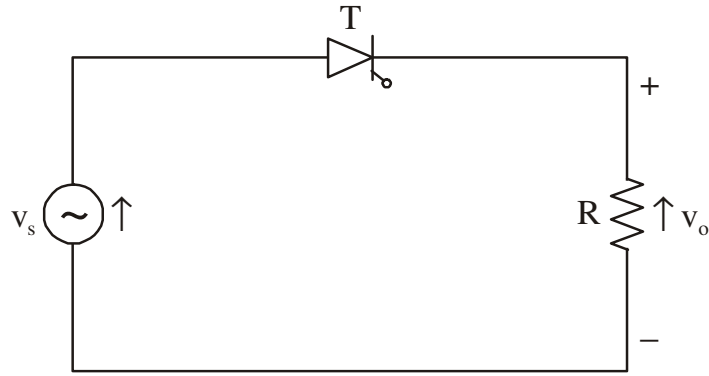

Fig. : Circuit for Natural Commutation

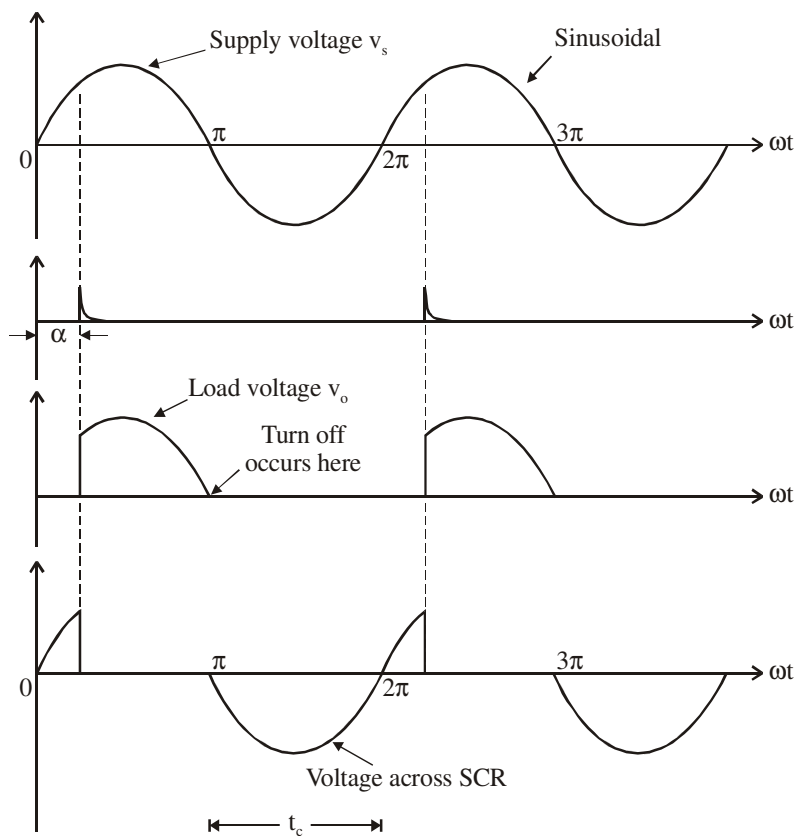

Fig. : Natural Commutation – Waveforms of Supply and Load Voltages (Resistive Load)

This type of commutation is applied in ac voltage controllers, phase controlled rectifiers and cyclo converters.

Forced Commutation

When supply is DC, natural commutation is not possible because the polarity of the supply remains unchanged. Hence special methods must be used to reduce the SCR current below the holding value or to apply a negative voltage across the SCR for a time interval greater than the turn off time of the SCR. This technique is called FORCED COMMUTATION and is applied in all circuits where the supply voltage is DC - namely,

Choppers (fixed DC to variable DC), inverters (DC to AC). Forced commutation techniques are as follows:

- Self Commutation
- Resonant Pulse Commutation
- Complementary Commutation
- Impulse Commutation
- External Pulse Commutation.
- Load Side Commutation.
- Line Side Commutation.

Self Commutation or Load Commutation or Class A Commutation: (Commutation By Resonating The Load)

In this type of commutation the current through the SCR is reduced below the holding current value by resonating the load. i.e., the load circuit is so designed that even though the supply voltage is positive, an oscillating current tends to flow and when the current through the SCR reaches zero, the device turns off. This is done by including an inductance and a capacitor in series with the load and keeping the circuit under-damped. Figure shows the circuit.

This type of commutation is used in Series Inverter Circuit.

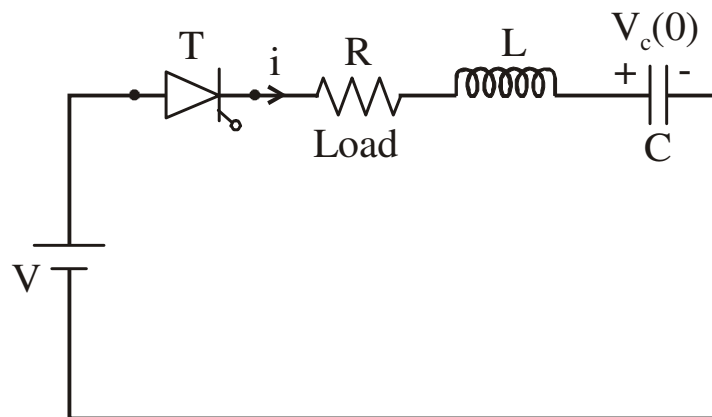
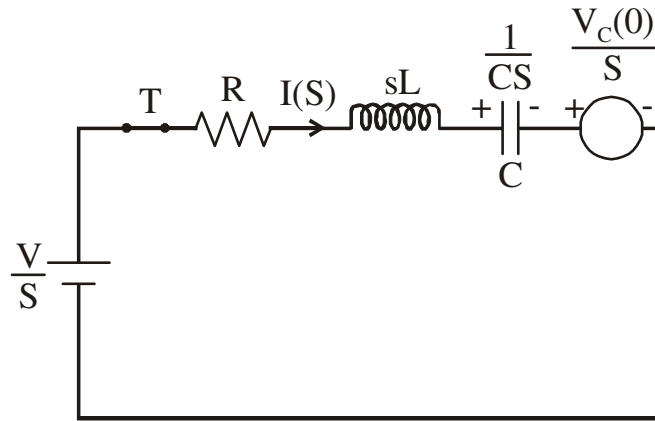

Fig: Circuit for Self Commutation

(i) Expression for Current

At $t = 0$, when the SCR turns ON on the application of gate pulse assume the current in the circuit is zero and the capacitor voltage is $V_c(0)$.

Writing the Laplace Transformation circuit of figure the following circuit is obtained when the SCR is conducting.



$$\begin{aligned}
 I(S) &= \frac{[V - V_c(0)]}{R + sL + \frac{1}{C_s}} \\
 &= \frac{C_s [V - V_c(0)]}{RC_s + s^2 LC + 1} \\
 &= \frac{C [V - V_c(0)]}{LC \left[s^2 + s \frac{R}{L} + \frac{1}{LC} \right]} \\
 &= \frac{V - V_c(0)}{s^2 + s \frac{R}{L} + \frac{1}{LC}} \\
 &= \frac{(V - V_c(0))}{L} \frac{1}{s^2 + s \frac{R}{L} + \frac{1}{LC} + \left(\frac{R}{2L} \right)^2 - \left(\frac{R}{2L} \right)^2} \\
 &= \frac{(V - V_c(0))}{L} \frac{1}{\left(s + \frac{R}{2L} \right)^2 + \left[\frac{1}{LC} - \left(\frac{R}{2L} \right)^2 \right]^2}
 \end{aligned}$$

$$= \frac{A}{(s + \delta)^2 + \omega^2},$$

Where

$$A = \frac{(V - V_c(0))}{L}, \quad \delta = \frac{R}{2L}, \quad \omega = \sqrt{\frac{1}{LC} - \left(\frac{R}{2L}\right)^2}$$

ω is called the natural frequency

$$I(S) = \frac{A}{\omega} \frac{\omega}{(s + \delta)^2 + \omega^2}$$

Taking inverse Laplace transforms

$$i(t) = \frac{A}{\omega} e^{-\delta t} \sin \omega t$$

Therefore expression for current

$$i(t) = \frac{V - V_c(0)}{\omega L} e^{-\frac{R}{2L}t} \sin \omega t$$

$$\text{Peak value of current} = \frac{(V - V_c(0))}{\omega L}$$

(ii) Expression for voltage across capacitor at the time of turn off

Applying KVL to figure 1.3

$$v_c = V - v_R - V_L$$

$$v_c = V - iR - L \frac{di}{dt}$$

Substituting for i ,

$$v_c = V - R \frac{A}{\omega} e^{-\delta t} \sin \omega t - L \frac{d}{dt} \left(\frac{A}{\omega} e^{-\delta t} \sin \omega t \right)$$

$$v_c = V - R \frac{A}{\omega} e^{-\delta t} \sin \omega t - L \frac{A}{\omega} \left(e^{-\delta t} \omega \cos \omega t - \delta e^{-\delta t} \sin \omega t \right)$$

$$v_c = V - \frac{A}{\omega} e^{-\delta t} [R \sin \omega t + \omega L \cos \omega t - L \delta \sin \omega t]$$

$$v_c = V - \frac{A}{\omega} e^{-\delta t} \left[R \sin \omega t + \omega L \cos \omega t - L \frac{R}{2L} \sin \omega t \right]$$

$$v_c = V - \frac{A}{\omega} e^{-\delta t} \left[\frac{R}{2} \sin \omega t + \omega L \cos \omega t \right]$$

Substituting for A,

$$v_c(t) = V - \frac{(V - V_c(0))}{\omega L} e^{-\delta t} \left[\frac{R}{2} \sin \omega t + \omega L \cos \omega t \right]$$

$$v_c(t) = V - \frac{(V - V_c(0))}{\omega} e^{-\delta t} \left[\frac{R}{2L} \sin \omega t + \omega \cos \omega t \right]$$

SCR turns off when current goes to zero. i.e., at $\omega t = \pi$.

Therefore at turn off

$$v_c = V - \frac{(V - V_c(0))}{\omega} e^{-\frac{\delta \pi}{\omega}} (0 + \omega \cos \pi)$$

$$v_c = V + [V - V_c(0)] e^{-\frac{\delta \pi}{\omega}}$$

Therefore
$$v_c = V + [V - V_c(0)] e^{-\frac{R\pi}{2L\omega}}$$

Note: For effective commutation the circuit should be under damped.

That is
$$\left(\frac{R}{2L} \right)^2 < \frac{1}{LC}$$

- With $R = 0$, and the capacitor initially uncharged that is $V_c(0) = 0$

$$i = \frac{V}{\omega L} \sin \frac{t}{\sqrt{LC}}$$

But
$$\omega = \frac{1}{\sqrt{LC}}$$

Therefore
$$i = \frac{V}{L} \sqrt{LC} \sin \frac{t}{\sqrt{LC}} = V \sqrt{\frac{C}{L}} \sin \frac{t}{\sqrt{LC}}$$

and capacitor voltage at turn off is equal to $2V$.

- Figure shows the waveforms for the above conditions. Once the SCR turns off voltage across it is negative voltage.
- Conduction time of SCR = $\frac{\pi}{\omega}$.

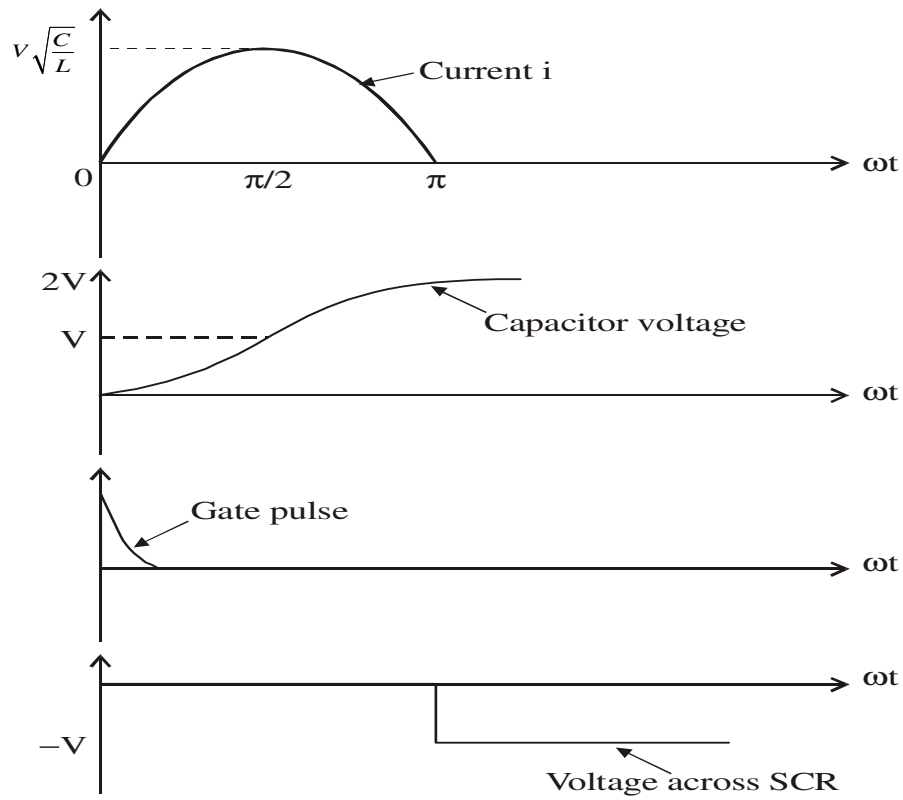

Fig. Self Commutation – Wave forms of Current and Capacitors Voltage

Resonant Pulse Commutation (Class B Commutation)

The circuit for resonant pulse commutation is shown in figure .

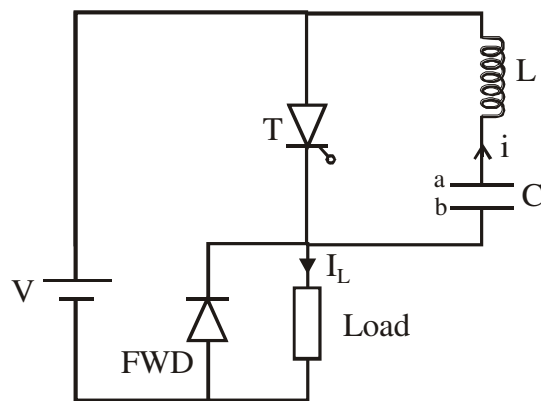

Fig. Circuit for Resonant Pulse Commutation

This is a type of commutation in which a LC series circuit is connected across the SCR. Since the commutation circuit has negligible resistance it is always under-damped i.e., the current in LC circuit tends to oscillate whenever the SCR is on.

Initially the SCR is off and the capacitor is charged to V volts with plate 'a' being positive. Referring to figure at $t = t_1$ the SCR is turned ON by giving a gate pulse. A current I_L flows through the load and this is assumed to be constant. At the same time SCR short circuits the LC combination which starts oscillating. A current 'i' starts flowing in the direction shown in figure. As 'i' reaches its maximum value, the capacitor voltage reduces to zero and then the polarity of the capacitor voltage reverses ('b' becomes positive). When 'i' falls to zero this reverse voltage becomes maximum, and then direction of 'i' reverses i.e., through SCR the load current I_L and 'i' flow in opposite direction. When the instantaneous value of 'i' becomes equal to I_L , the SCR current becomes zero and the SCR turns off. Now the capacitor starts charging and its voltage reaches the supply voltage with plate a being positive. The related waveforms are shown in figure .

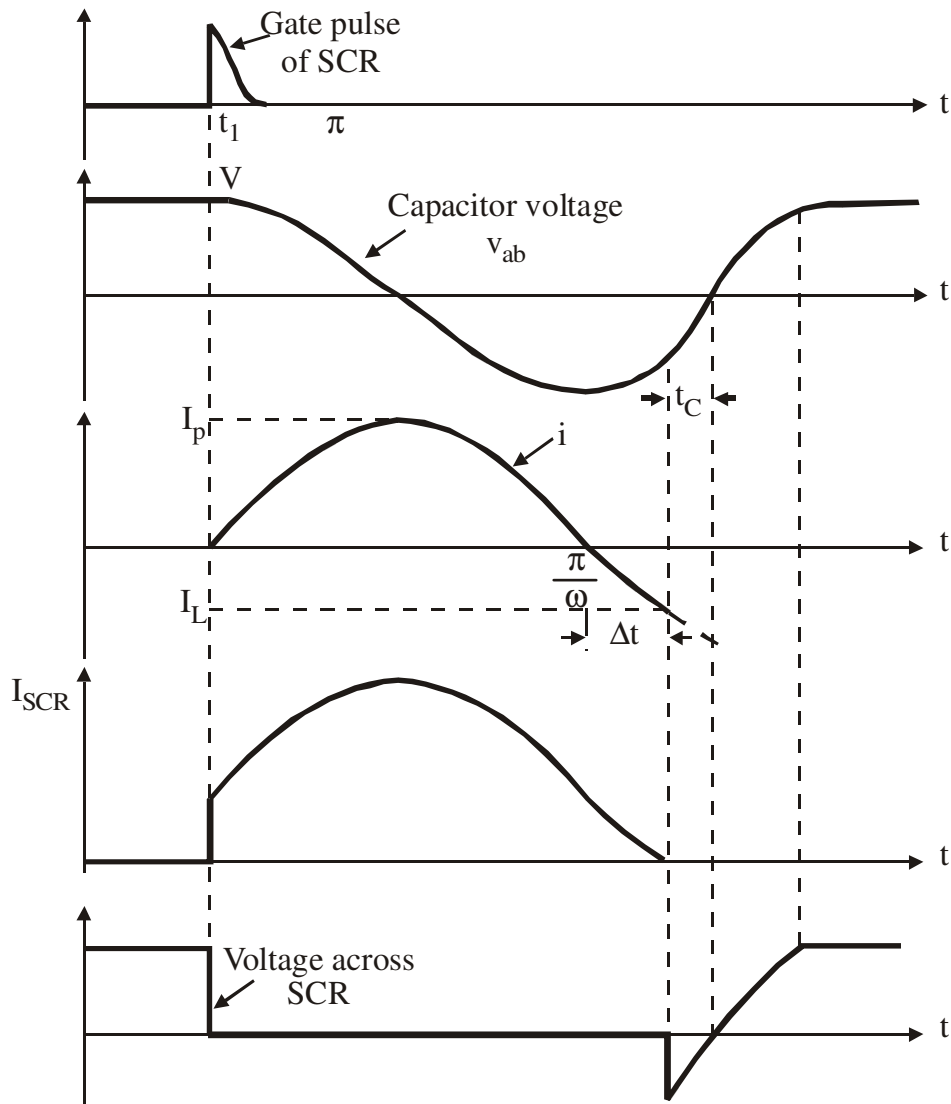

Fig. Resonant Pulse Commutation – Various Waveforms

(i) Expression For t_c , The Circuit Turn Off Time

Assume that at the time of turn off of the SCR the capacitor voltage $v_{ab} \approx -V$ and load current I_L is constant. t_c is the time taken for the capacitor voltage to reach 0 volts from $-V$ volts and is derived as follows.

$$V = \frac{1}{C} \int_0^{t_c} I_L dt$$

$$V = \frac{I_L t_c}{C}$$

$$t_c = \frac{VC}{I_L} \text{ seconds}$$

For proper commutation t_c should be greater than t_q , the turn off time of T. Also, the magnitude of I_p , the peak value of i should be greater than the load current I_L and the expression for i is derived as follows

The LC circuit during the commutation period is shown in figure .

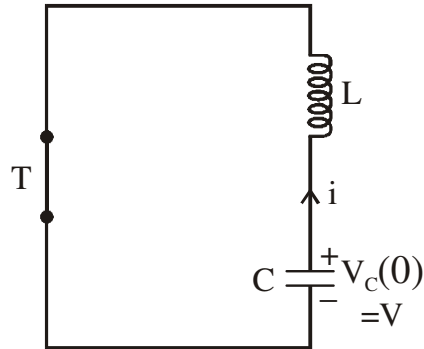

The transformed circuit is shown in figure .

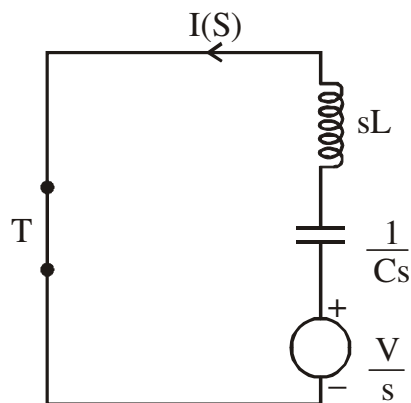

$$I(S) = \frac{\frac{V}{s}}{sL + \frac{1}{Cs}}$$

$$I(S) = \frac{\left(\frac{V}{s}\right)Cs}{s^2LC + 1}$$

$$I(S) = \frac{VC}{LC\left(s^2 + \frac{1}{LC}\right)}$$

$$I(S) = \frac{V}{L} \times \frac{1}{s^2 + \frac{1}{LC}}$$

$$I(S) = \frac{V}{L} \times \frac{\left(\frac{1}{\sqrt{LC}}\right)}{s^2 + \frac{1}{LC}} \times \frac{1}{\left(\frac{1}{\sqrt{LC}}\right)}$$

$$I(S) = V \sqrt{\frac{C}{L}} \times \frac{\left(\frac{1}{\sqrt{LC}}\right)}{s^2 + \frac{1}{LC}}$$

Taking inverse LT

$$i(t) = V \sqrt{\frac{C}{L}} \sin \omega t$$

Where $\omega = \frac{1}{\sqrt{LC}}$

Or $i(t) = \frac{V}{\omega L} \sin \omega t = I_p \sin \omega t$

Therefore $I_p = V \sqrt{\frac{C}{L}}$ amps.

(ii) Expression for Conduction Time of SCR

For figure 5.13 (waveform of i), the conduction time of SCR

$$= \frac{\pi}{\omega} + \Delta t$$

$$= \frac{\pi}{\omega} + \frac{\sin^{-1}\left(\frac{I_L}{I_p}\right)}{\omega}$$

Alternate Circuit for Resonant Pulse Commutation

The working of the circuit can be explained as follows. The capacitor C is assumed to be charged to $V_c(0)$ with polarity as shown, T_1 is conducting and the load current I_L is a constant. To turn off T_1 , T_2 is triggered. L, C, T_1 and T_2 forms a resonant circuit. A resonant

current $i_c(t)$, flows in the direction shown, i.e., in a direction opposite to that of load current I_L .

$i_c(t) = I_p \sin \omega t$ (refer to the previous circuit description). Where $I_p = V_c(0) \sqrt{\frac{C}{L}}$ & and the capacitor voltage is given by

$$v_c(t) = \frac{1}{C} \int i_c(t).dt$$

$$v_c(t) = \frac{1}{C} \int V_c(0) \sqrt{\frac{C}{L}} \sin \omega t .dt .$$

$$v_c(t) = -V_c(0) \cos \omega t$$

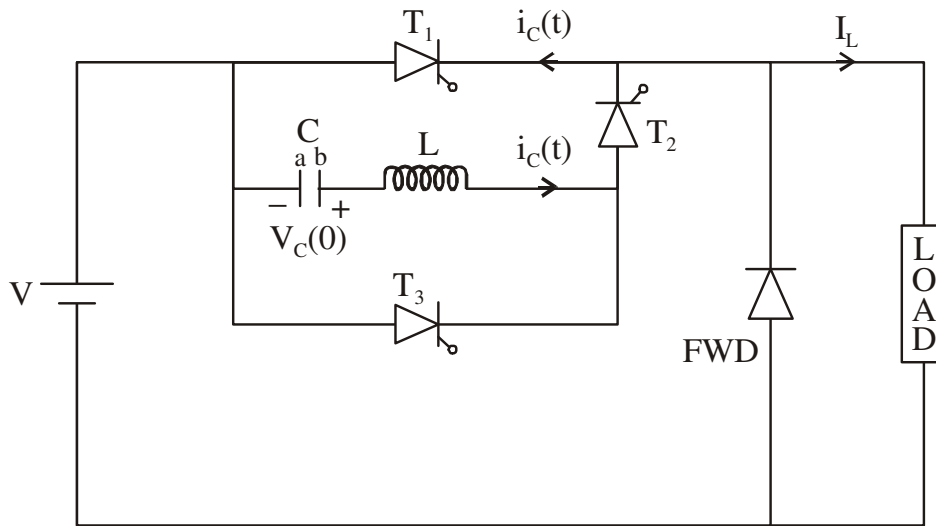

Fig. Resonant Pulse Commutation – An Alternate Circuit

When $i_c(t)$ becomes equal to I_L (the load current), the current through T_1 becomes zero and T_1 turns off. This happens at time t_1 such that

$$I_L = I_p \sin \frac{t_1}{\sqrt{LC}}$$

$$I_p = V_c(0) \sqrt{\frac{C}{L}}$$

$$t_1 = \sqrt{LC} \sin^{-1} \left(\frac{I_L}{V_c(0) \sqrt{\frac{L}{C}}} \right)$$

and the corresponding capacitor voltage is

$$v_c(t_1) = -V_1 = -V_C(0) \cos \omega t_1$$

Once the thyristor T_1 turns off, the capacitor starts charging towards the supply voltage through T_2 and load. As the capacitor charges through the load capacitor current is same as load current I_L , which is constant. When the capacitor voltage reaches V , the supply voltage, the FWD starts conducting and the energy stored in L charges C to a still higher voltage. The triggering of T_3 reverses the polarity of the capacitor voltage and the circuit is ready for another triggering of T_1 . The waveforms are shown in figure.

Expression For t_c

Assuming a constant load current I_L which charges the capacitor

$$t_c = \frac{CV_1}{I_L} \text{ seconds}$$

Normally $V_1 \approx V_C(0)$

For reliable commutation t_c should be greater than t_q , the turn off time of SCRT₁. It is to be noted that t_c depends upon I_L and becomes smaller for higher values of load current.

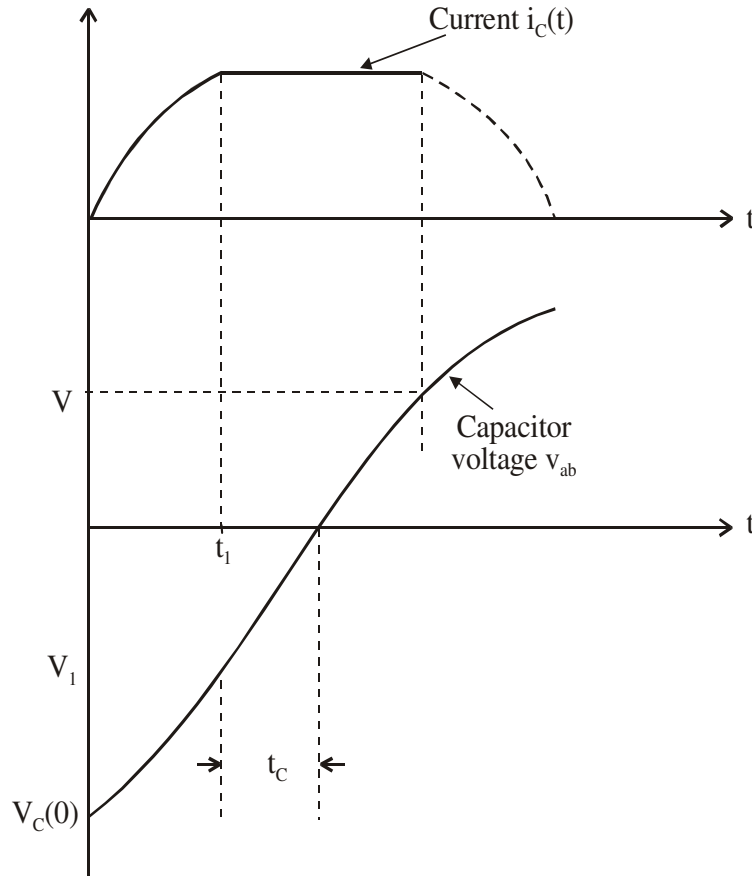

Fig. Resonant Pulse Commutation – Alternate Circuit – Various Waveforms

Complementary Commutation (Class C Commutation, Parallel Capacitor Commutation)

In complementary commutation the current can be transferred between two loads. Two SCRs are used and firing of one SCR turns off the other. The circuit is shown in figure

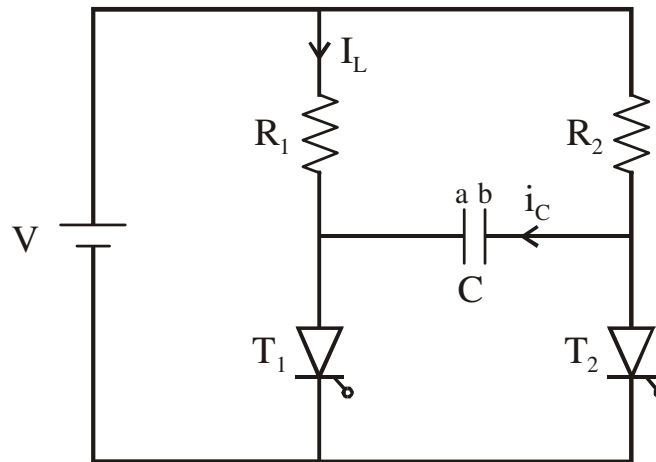

Fig. Complementary Commutation

The working of the circuit can be explained as follows.

Initially both T_1 and T_2 are off; now, T_1 is fired. Load current I_L flows through R_1 . At the same time, the capacitor C gets charged to V volts through R_2 and T_1 ('b' becomes positive with respect to 'a'). When the capacitor gets fully charged, the capacitor current i_c becomes zero.

To turn off T_1 , T_2 is fired; the voltage across C comes across T_1 and reverse biases it, hence T_1 turns off. At the same time, the load current flows through R_2 and T_2 . The capacitor 'C' charges towards V through R_1 and T_2 and is finally charged to V volts with 'a' plate positive. When the capacitor is fully charged, the capacitor current becomes zero. To turn off T_2 , T_1 is triggered, the capacitor voltage (with 'a' positive) comes across T_2 and T_2 turns off. The related waveforms are shown in figure .

(i) Expression for Circuit Turn Off Time t_c

From the waveforms of the voltages across T_1 and capacitor, it is obvious that t_c is the time taken by the capacitor voltage to reach 0 volts from $-V$ volts, the time constant being RC and the final voltage reached by the capacitor being V volts. The equation for capacitor voltage $v_c(t)$ can be written as

$$v_c(t) = V_f + (V_i - V_f) e^{-t/\tau}$$

Where V_f is the final voltage, V_i is the initial voltage and τ is the time constant.

At $t = t_c$, $v_c(t) = 0$,

$$= R_1 C, V_f = V, V_i = -V,$$

Therefore $0 = V + (-V - V)e^{\frac{-t_c}{R_1 C}}$

$$0 = V - 2Ve^{\frac{-t_c}{R_1 C}}$$

Therefore $V = 2Ve^{\frac{-t_c}{R_1 C}}$

$$0.5 = e^{\frac{-t_c}{R_1 C}}$$

Taking natural logarithms on both sides

$$\ln 0.5 = \frac{-t_c}{R_1 C}$$

$$t_c = 0.693R_1 C$$

This time should be greater than the turn off time t_q of T_1 .

Similarly when T_2 is commutated

$$t_c = 0.693R_2 C$$

And this time should be greater than t_q of T_2 .

Usually $R_1 = R_2 = R$

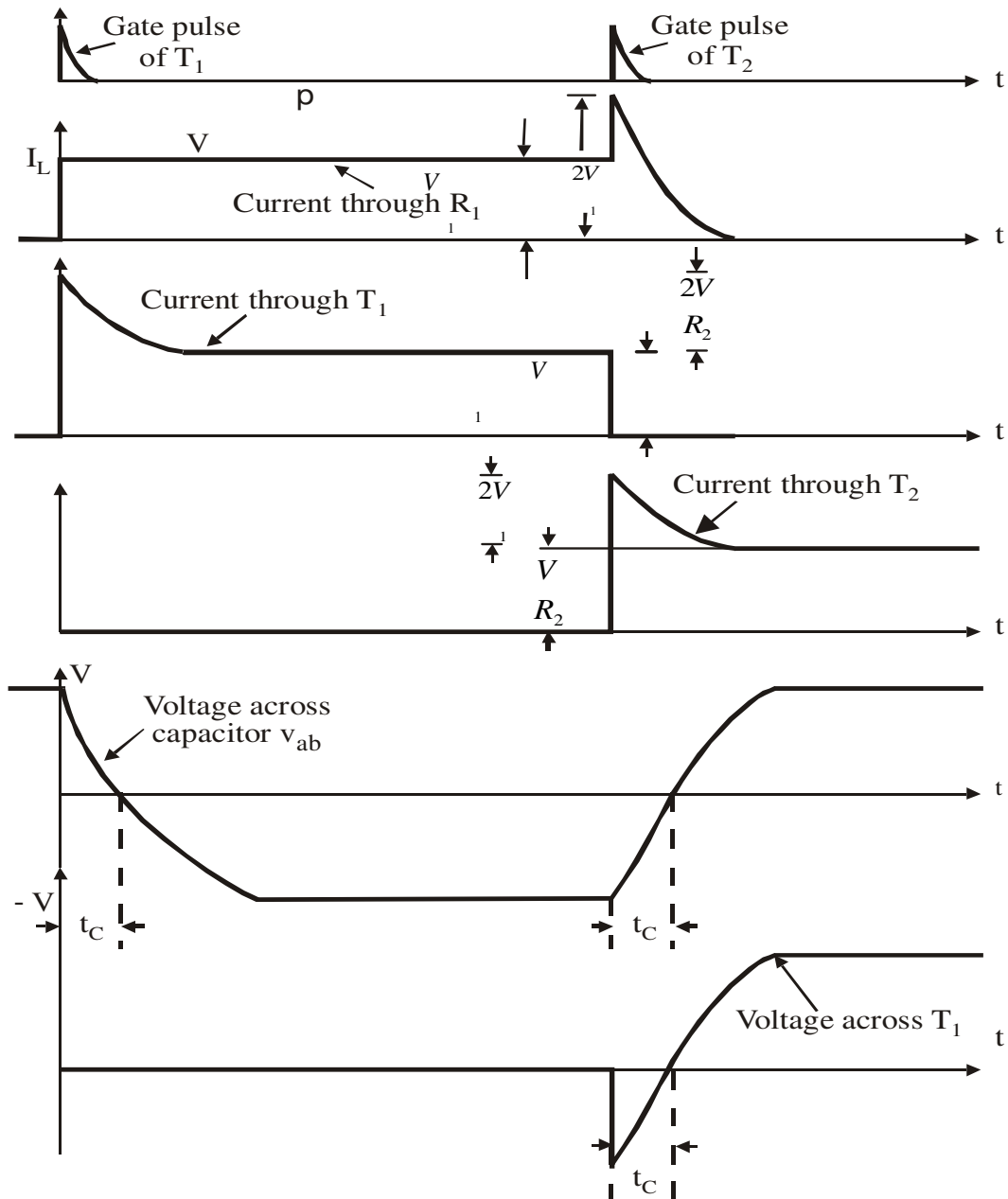

Impulse Commutation (CLASS D Commutation)

The circuit for impulse commutation is as shown in figure .

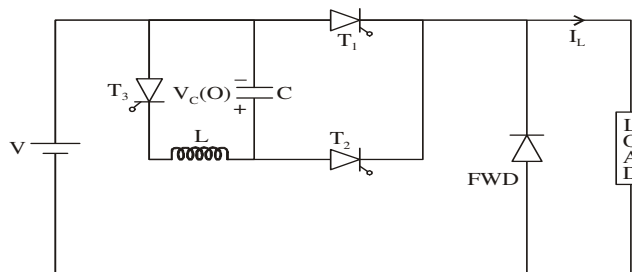

Fig. Circuit for Impulse Commutation

The working of the circuit can be explained as follows. It is assumed that initially the capacitor C is charged to a voltage $V_c(O)$ with polarity as shown. Let the thyristor T_1 be

conducting and carry a load current I_L . If the thyristor T_1 is to be turned off, T_2 is fired. The capacitor voltage comes across T_1 , T_1 is reverse biased and it turns off. Now the capacitor starts charging through T_2 and the load. The capacitor voltage reaches V with top plate being positive. By this time the capacitor charging current (current through T_2) would have reduced to zero and T_2 automatically turns off. Now T_1 and T_2 are both off. Before firing T_1 again, the capacitor voltage should be reversed. This is done by turning on T_3 , C discharges through T_3 and L and the capacitor voltage reverses. The waveforms are shown in figure .

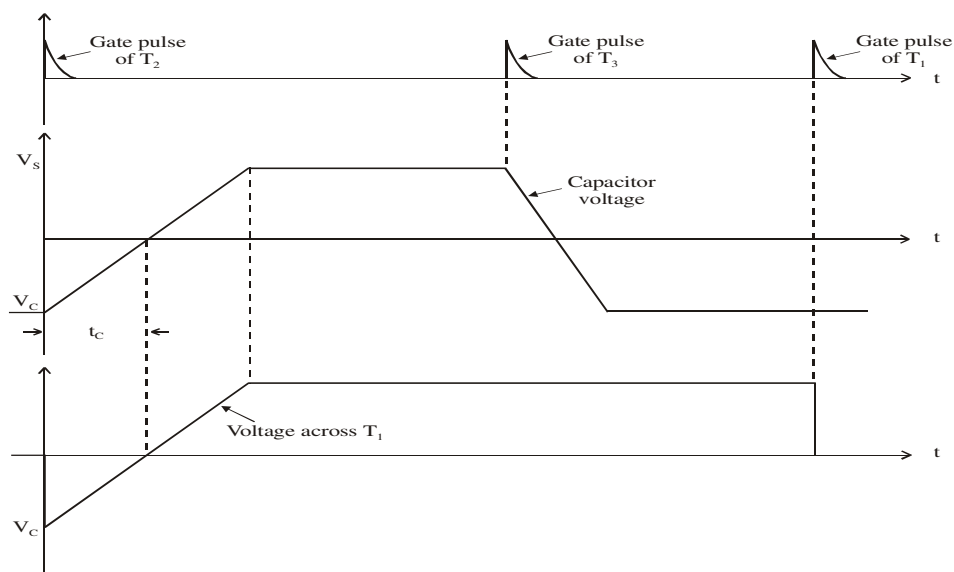

Fig.Impulse Commutation – Waveforms of Capacitor Voltage, Voltage across T_1 .

(i) Expression for Circuit Turn Off Time (Available Turn Off Time) t_c

t_c depends on the load current I_L and is given by the expression

$$V_C = \frac{1}{C} \int_0^{t_c} I_L dt$$

(assuming the load current to be constant)

$$V_C = \frac{I_L t_c}{C}$$

$$t_c = \frac{V_C C}{I_L} \text{ seconds}$$

For proper commutation t_c should be $> t_q$, turn off time of T_1 .

External Pulse Commutation (Class E Commutation)

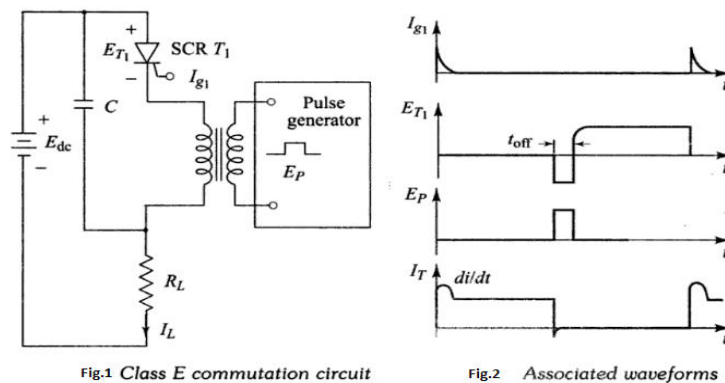

Fig.1 Class E commutation circuit

Fig.2 Associated waveforms

Fig. External Pulse Commutation

In this type of commutation an additional source is required to turn-off the conducting thyristor. Figure shows a circuit for external pulse commutation. V_S is the main voltage source and V_{AUX} is the auxiliary supply. Assume thyristor T_1 is conducting and load R_L is connected across supply V_S . When thyristor T_3 is turned ON at $t = 0$, V_{AUX} , T_3 , L and C form an oscillatory circuit. Assuming capacitor is initially uncharged, capacitor C is now charged to a voltage $2V_{AUX}$ with upper plate positive at $t = \pi\sqrt{LC}$. When current through T_3 falls to zero, T_3 gets commutated. To turn-off the main thyristor T_1 , thyristor T_2 is turned ON. Then T_1 is subjected to a reverse voltage equal to $V_S - 2V_{AUX}$. This results in thyristor T_1 being turned-off. Once T_1 is off capacitor 'C' discharges through the load R_L .

Load Side Commutation

In load side commutation the discharging and recharging of capacitor takes place through the load. Hence to test the commutation circuit the load has to be connected. Examples of load side commutation are Resonant Pulse Commutation and Impulse Commutation.

Line Side Commutation

In this type of commutation the discharging and recharging of capacitor takes place through the supply.

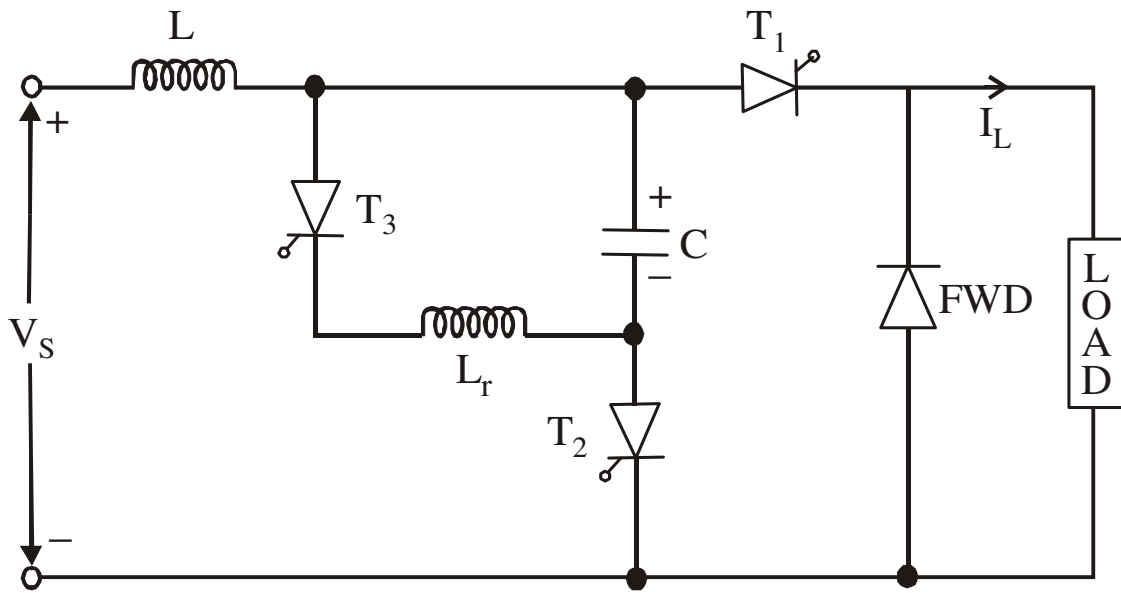

Fig.: Line Side Commutation Circuit

Figure shows line side commutation circuit. Thyristor T_2 is fired to charge the capacitor 'C'. When 'C' charges to a voltage of $2V$, T_2 is self commutated. To reverse the voltage of capacitor to $-2V$, thyristor T_3 is fired and T_3 commutates by itself. Assuming that T_1 is conducting and carries a load current I_L thyristor T_2 is fired to turn off T_1 . The turning ON of T_2 will result in forward biasing the diode (FWD) and applying a reverse voltage of $2V$ across T_1 . This turns off T_1 , thus the discharging and recharging of capacitor is done through the supply and the commutation circuit can be tested without load.

INSULATED GATE BIPOLAR TRANSISTOR(IGBT)-

BASIC CONSTRUCTION-

The n+ layer substrate at the drain in the power MOSFET is substituted by p+ layer substrate and called as collector. When gate to emitter voltage is positive, n- channel is formed in the p- region. This n- channel short circuit the n- and n+ layer and an electron movement in n channel cause hole injection from p+ substrate layer to n- layer.

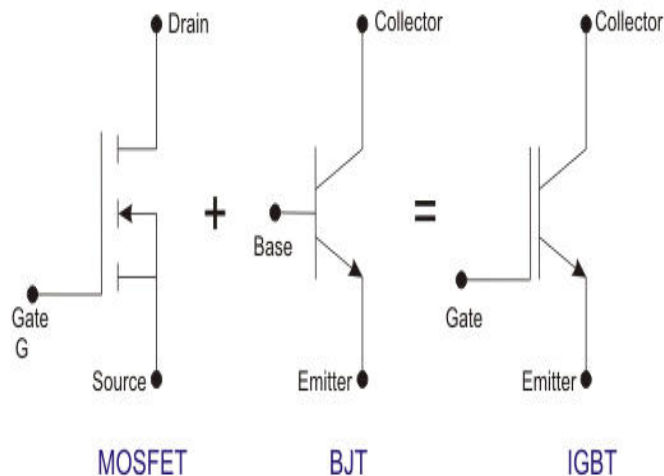
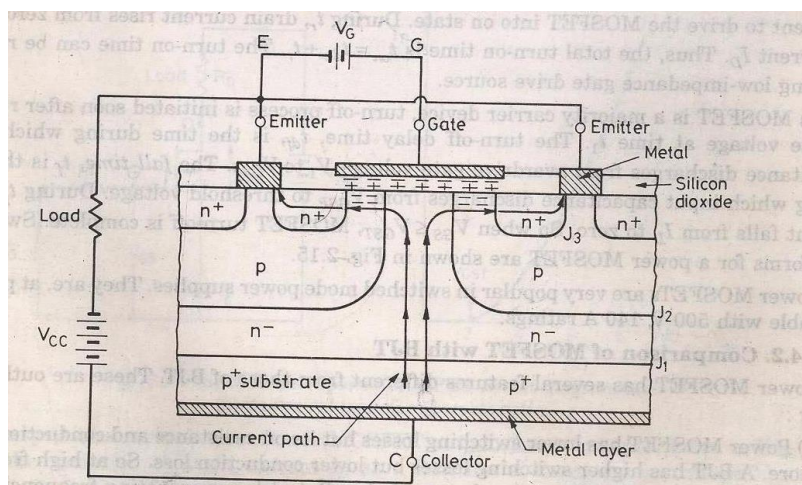

POWER MOSFET

A power MOSFET has three terminal device. Arrow indicates the direction of current flow. MOSFET is a voltage controlled device. The operation of MOSFET depends on flow of majority carriers only.

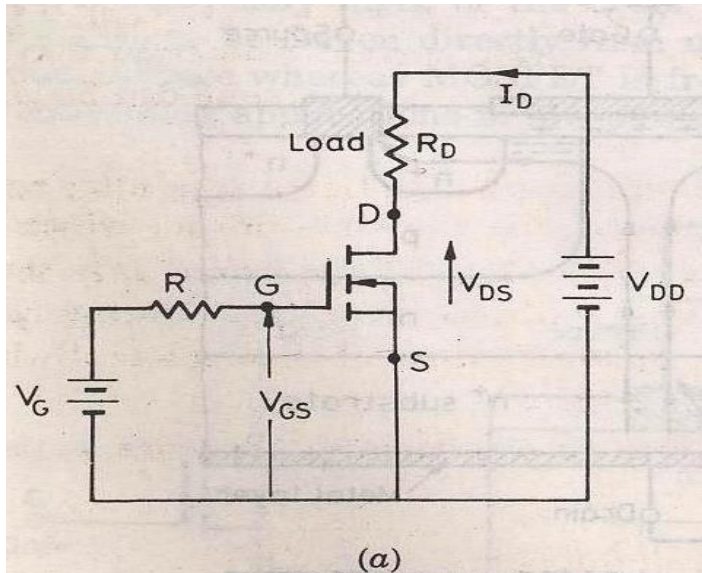

(Circuit diagram)

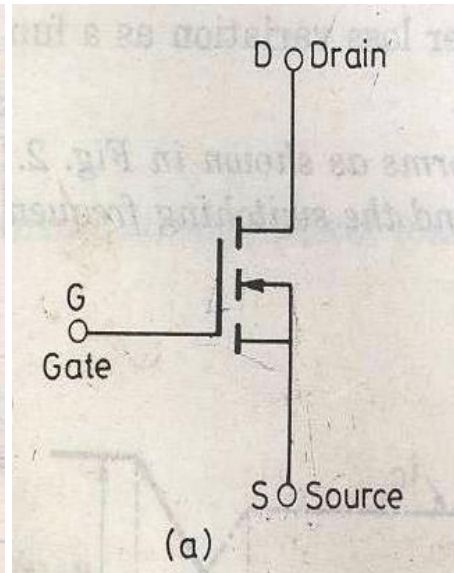

(circuit symbol)

Switching Characteristics:-

The switching characteristic is influenced by

1. Internal capacitance of the device.
2. Internal impedance of the gate drive circuit.

Total **turn on time** is divided into

1. Turn on delay time
2. Rise time

Turn on time is affected by impedance of gate drive source. During turn on delay time gate to source voltage attains its threshold value V_{GST} .

After t_{an} and during rise time gate to source voltage rise to V_{GSP} , a voltage which is sufficient to drive the MOSFET to ON state.

The turn off process is initiated by removing the gate to source voltage. Turn off time is composed of turn off delay time to fall time.

Turn off delay time

To turn off the MOSFET the input capacitance has to be discharged . During t_{df} the input capacitance discharge from V_1 to V_{GSP} . During t_f , fall time ,the input capacitance discharges from V_{GSP} to V_{GST} . During t_f drain current falls from I_D to zero.

So when $V_{GS} \leq V_{GST}$, MOSFET turn off is complete.

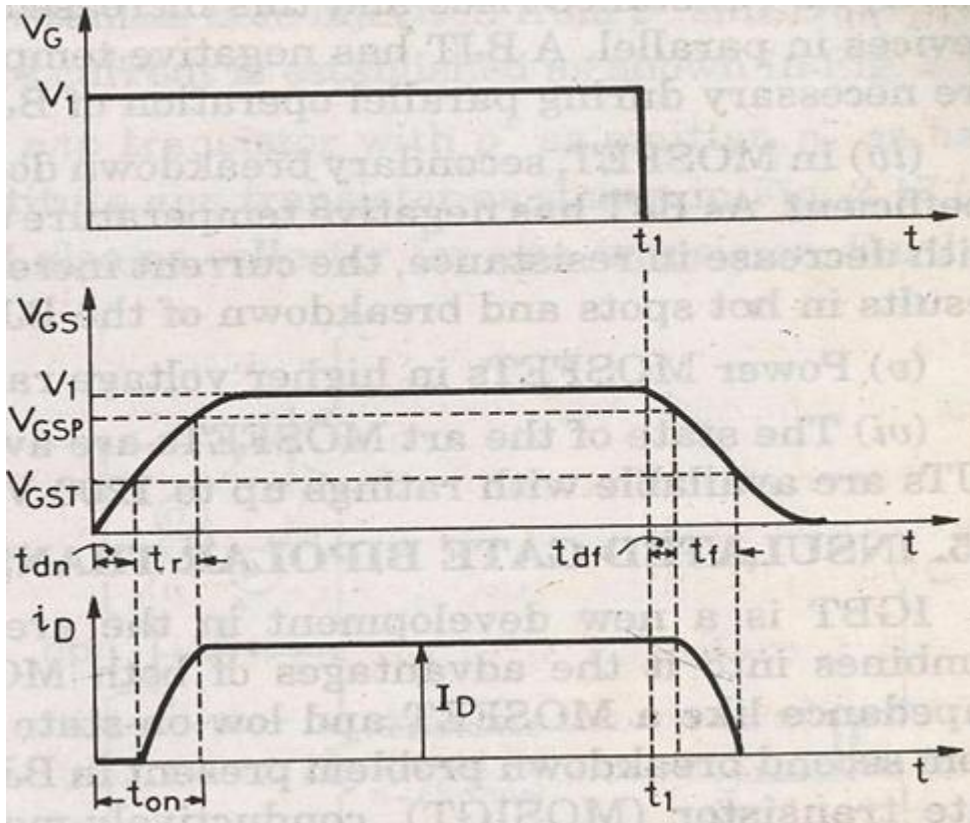

Fig. Switching waveform of power MOSFET

Insulated Gate Bipolar Transistor (IGBT)

IGBT has high input impedance like MOSFET and low on state power loss as in BJT.

IGBT Characteristics

Here the controlling parameter is gate emitter voltage As IGBT is a voltage controlled device.

When V_{GE} is less than V_{GET} that is gate emitter threshold voltage IGBT is in off state.

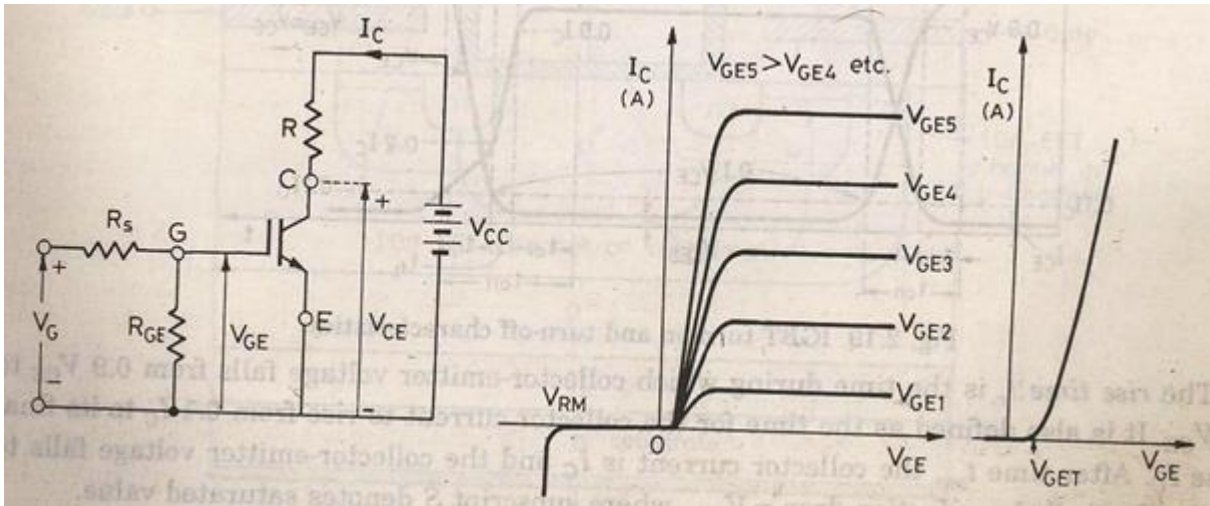

Fig. a

Fig. b.

Fig. c

Fig. a (Circuit diagram for obtaining V-I characteristics)

Fig. b (Static V-I characteristics)

Fig. c (Transfer characteristic)

Switching characteristics: Figure below shows the turn ON and turn OFF characteristics of IGBT

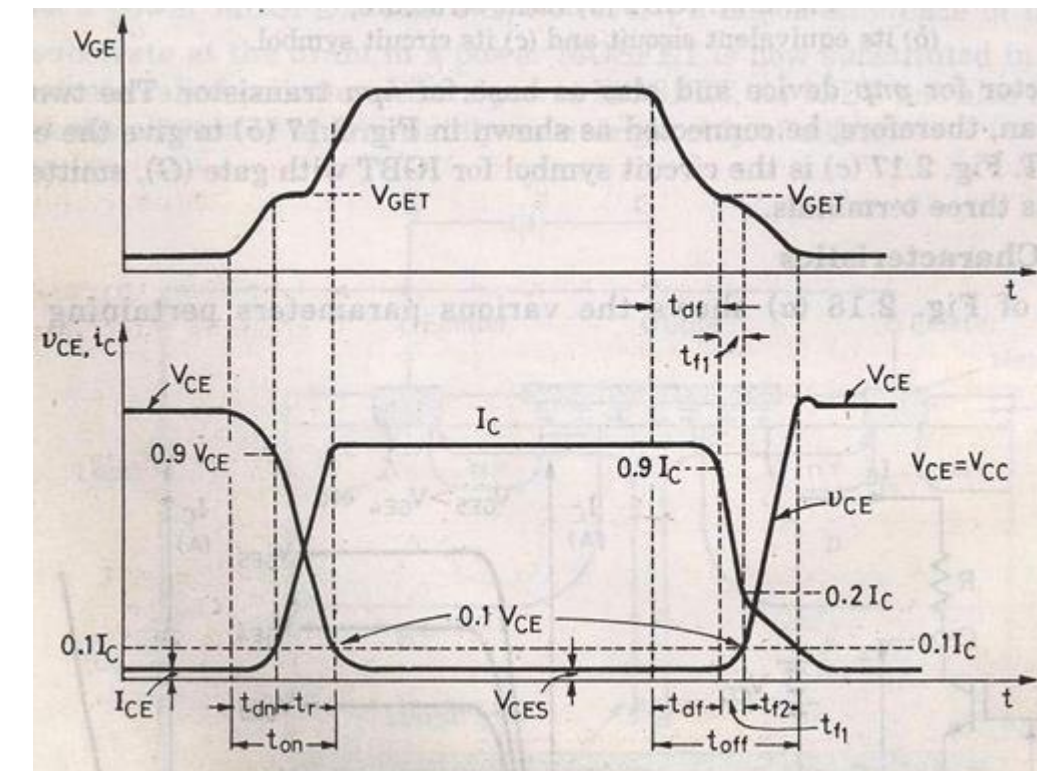

Turn on time

Time between the instants forward blocking state to forward on -state .

Turn on time = Delay time + Rise time

Delay time = Time for collector emitter voltage fall from V_{CE} to $0.9V_{CE}$

V_{CE} =Initial collector emitter voltage

t_{dn} =collector current to rise from initial leakage current to $0.1I_c$

I_c = Final value of collector current

Rise time

Collector emitter voltage to fall from $0.9V_{CE}$ to $0.1V_{CE}$.

$0.1I_c$ to I_c

After t_{on} the device is on state the device carries a steady current of I_c and the collector emitter voltage falls to a small value called conduction drop V_{CES} .

Turn off time

- 1) Delay time t_{df}
- 2) Initial fall time t_{f1}
- 3) Final fall time t_{f2}

$$t_{off} = t_{df} + t_{f1} + t_{f2}$$

t_{df} = Time during which the gate emitter voltage falls to the threshold value V_{GET} .

Collector current falls from I_c to $0.9I_c$ at the end of the t_{df} collector emitter voltage begins to rise.

Turn off time = Collector current falls from 90% to 20% of its initial value I_c OR The time during which collector emitter voltage rise from V_{CE} to $0.1V_{CE}$.

t_{f2} = collector current falls from 20% to 10% of I_c .

During this collector emitter voltage rise $0.1V_{CE}$ to final value of V_{CE} .

Series and parallel operation of SCR

SCR are connected in series for h.v demand and in parallel for fulfilling high current demand. String efficiency can be defined as measure of the degree of utilization on SCRs in a string.

String efficiency < 1 .

Derating factor (DRF) = $1 - \text{string efficiency}$.

Thyristor gate characteristics:-

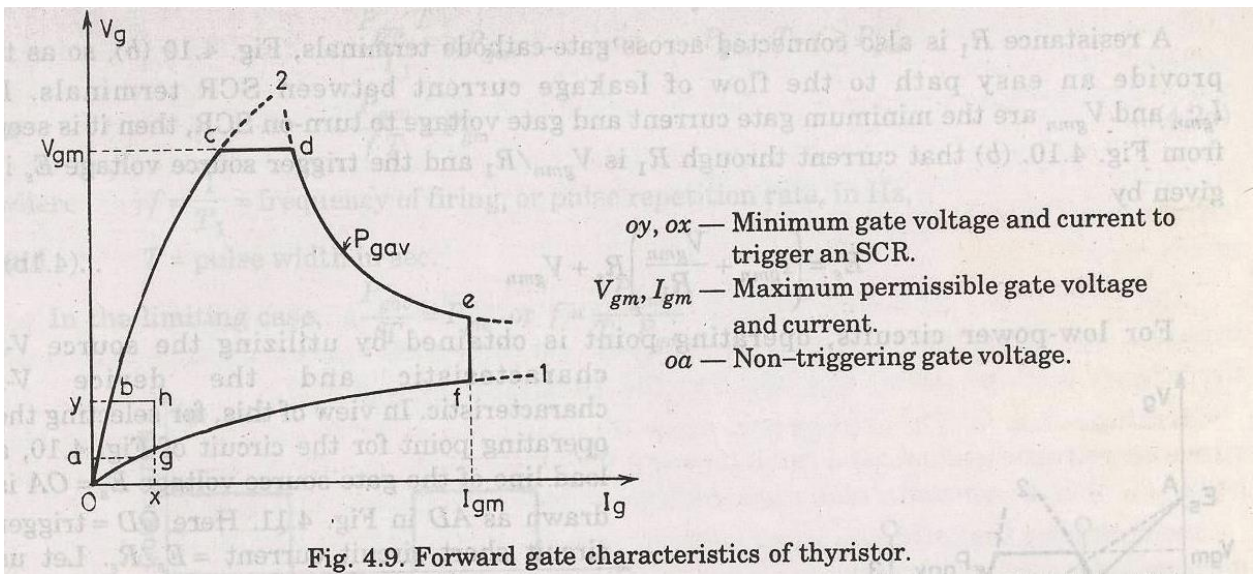

$V_g = +ve$ gate to cathode voltage.

$I_g = +ve$ gate to cathode current.

As the gate cathode characteristic of a thyristor is a p-n junction, gate characteristic of the device is similar to diode.

Curve 1 the lowest voltage value s that must be applied to turn on the SCR.

Curve 2 highest possible voltage values that can be safely applied to get circuit.

V_{gm} = Maximum limit for gate voltage .

I_{gm} = Maximum imilt for gate current.

P_{gav} = Rated gate power dissipation for each SCR.

These limits should not be crossed in order to avoid the permanent damage of the device junction J_3 .

OY = Minimum limit of gate voltage to turn ON .

OX = minimum limit of gate current to turn ON.

If V_{gm} , I_{gm} , P_{gav} are exceeded the thyristor will damage so the preferred gate drive area of SCR is bdefghb.

oa = The non triggering gate voltage , If firing circuit generates +ve gate signal prior to the desired instant of triggering the SCR.It should be ensured that this unwanted signal should be less than the non –triggering voltage oa.

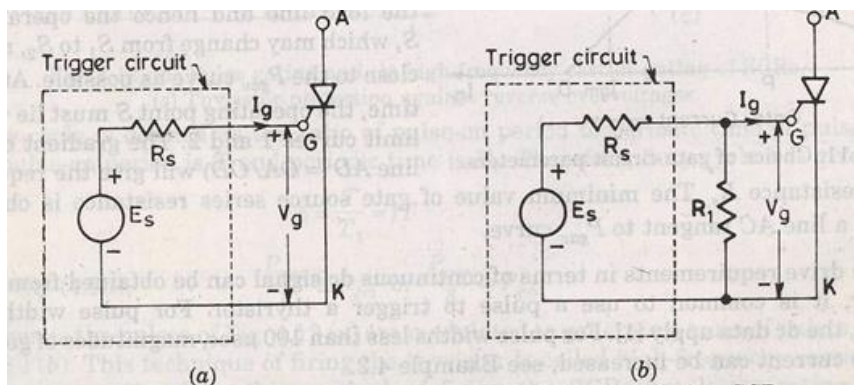

$$E_s = V_g + I_g R_s$$

E_s = Gate source voltage

V_g = Gate cathode voltage

I_g = Gate current

R_s = Gate source resistance

R_s = The internal resistance of the trigger source

R_1 is connected across the gate cathode terminal, which provides an easy path to the flow of leakage current between SCR terminal. If I_{gmn} , V_{gmn} are the minimum gate current and gate voltage to turn ON the SCR.

$$E_s = (I_{gmn} + V_{gmn} / R_1) R_s + V_{gmn}$$

MODULE-II

PHASE CONTROLLED RECTIFIER

Rectifier are used to convert A.C to D.C supply.

Rectifiers can be classified as single phase rectifier and three phase rectifier. Single phase rectifier are classified as 1- Φ half wave and 1- Φ full wave rectifier. Three phase rectifier are classified as 3- Φ half wave rectifier and 3- Φ full wave rectifier. 1- Φ Full wave rectifier are classified as 1- Φ mid point type and 1- Φ bridge type rectifier. 1- Φ bridge type rectifier are classified as 1- Φ half controlled and 1- Φ full controlled rectifier. 3- Φ full wave rectifier are again classified as 3- Φ mid point type and 3- Φ bridge type rectifier. 3- Φ bridge type rectifier are again divided as 3- Φ half controlled rectifier and 3- Φ full controlled rectifier.

Single phase half wave circuit with R-L load

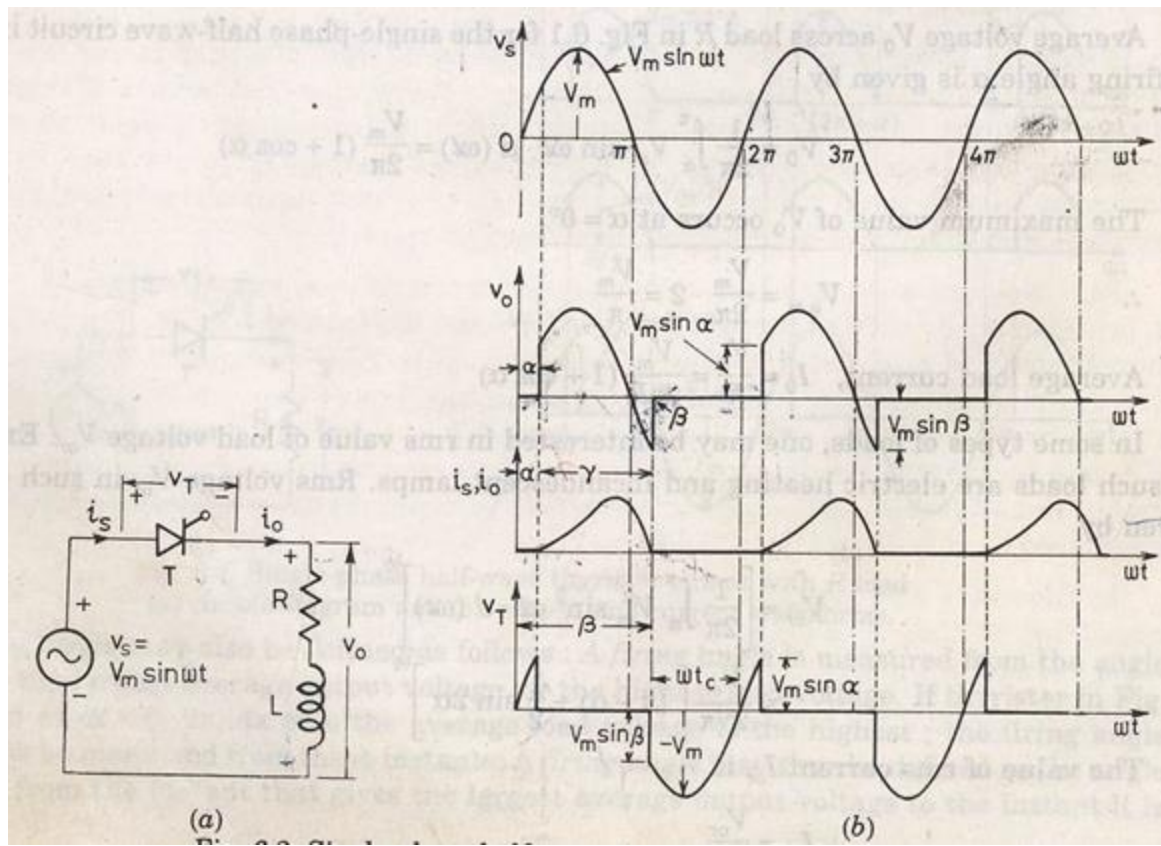

Output current i_o rises gradually. After some time i_o reaches a maximum value and then begins to decrease.

At π , $v_o=0$ but i_o is not zero because of the load inductance L . After π interval SCR is reverse biased but load current is not less than the holding current.

At $\beta > \pi$, i_o reduces to zero and SCR is turned off.

At $2\pi + \beta$ SCR triggers again

α is the firing angle.

β is the extinction angle.

$$v = \beta - \alpha = \text{conduction angle}$$

Analysis for V_T .

$$\text{At } \omega t = 0, V_T = V_m \sin \omega t$$

$$V_m \sin \omega t = Ri_0 + L \frac{di_0}{dt}$$

$$i_s = \frac{V_m}{\sqrt{R^2 + X^2}} \sin(\omega t - \phi)$$

Where,

$$\phi = \tan^{-1} \frac{X}{R}$$

$$X = \omega L$$

Where α is the angle by which I_s lags V_s .

The transient component can be obtained as

$$Ri_t + L \frac{di_t}{dt} = 0$$

$$\text{So } i_t = Ae^{-(Rt/L)}$$

$$i_0 = i_s + i_t$$

$$\frac{V_m}{z} \sin(\omega t - \theta) + Ae^{-(Rt/L)}$$

$$\text{Where } z = \sqrt{R^2 + X^2}$$

$$\text{At } \alpha = \omega t, i_0 = 0;$$

Therefore,

$$\omega t = \beta, i_0 = 0;$$

$$\text{So } \sin(\beta - \alpha) = \sin(\alpha - \beta)e^{-(\beta - \alpha)/(\omega L)}$$

β can be obtained from the above equation.

The average load voltage can be given by

$$V_0 = \frac{1}{2\pi} \int_{\alpha}^{\beta} V_m \sin \omega t d(\omega t)$$

$$\frac{V_m}{2\pi} (\cos(\alpha) - \cos(\beta))$$

Average load current

$$I_0 = \frac{V_m}{2\pi R} (\cos \alpha - \cos \beta)$$

Single phase full converter

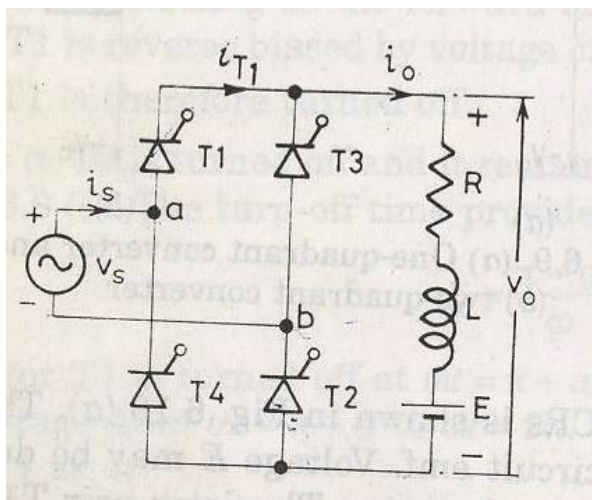

$$V_0 = \frac{1}{\pi} \int_{\alpha}^{\pi + \beta} V_m \sin(\omega t) d(\omega t)$$

$$= \frac{2V_m}{\pi} \cos \alpha$$

T_1, T_2 triggered at α and π radian latter T_3, T_4 are triggered.

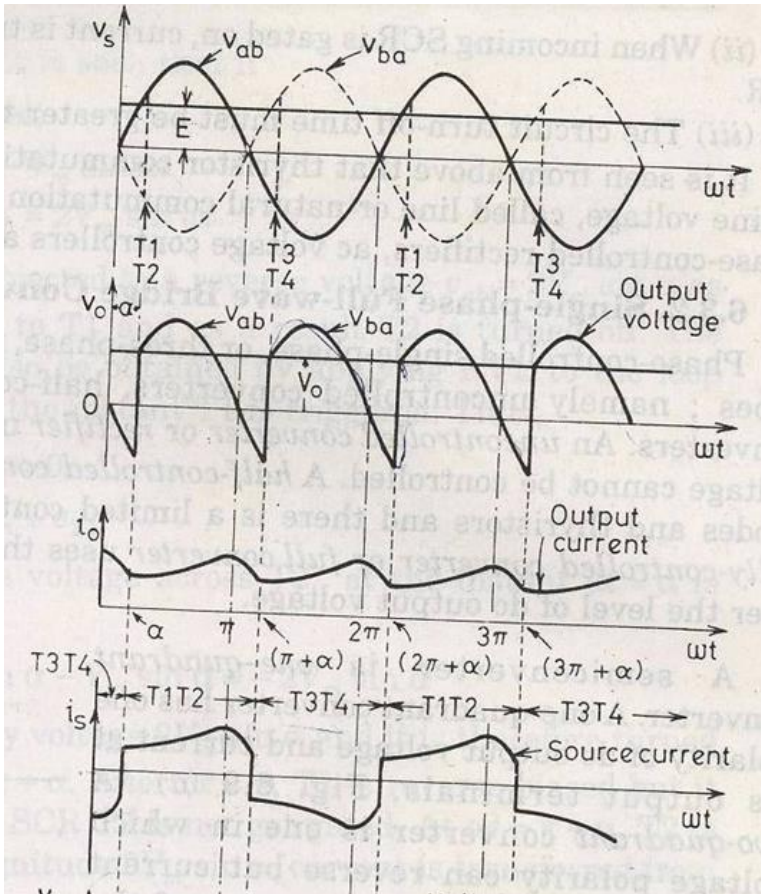

Single phase half wave circuit with RLE load

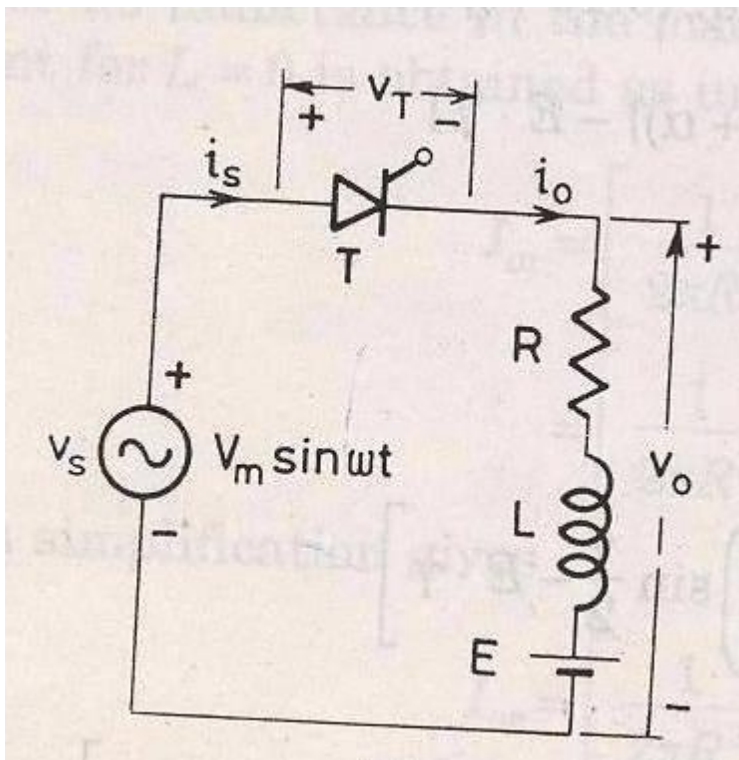

The minimum value of firing angle is

$$V_m \sin(\omega t) = E$$

So,

$$\theta_1 = \sin^{-1} \frac{E}{V_m}$$

Maximum value of firing angle

$$\theta_2 = \pi - \theta_1$$

The voltage differential equation is

$$V_m \sin(\omega t) = Ri_0 + L \frac{di_0}{dt} + E$$

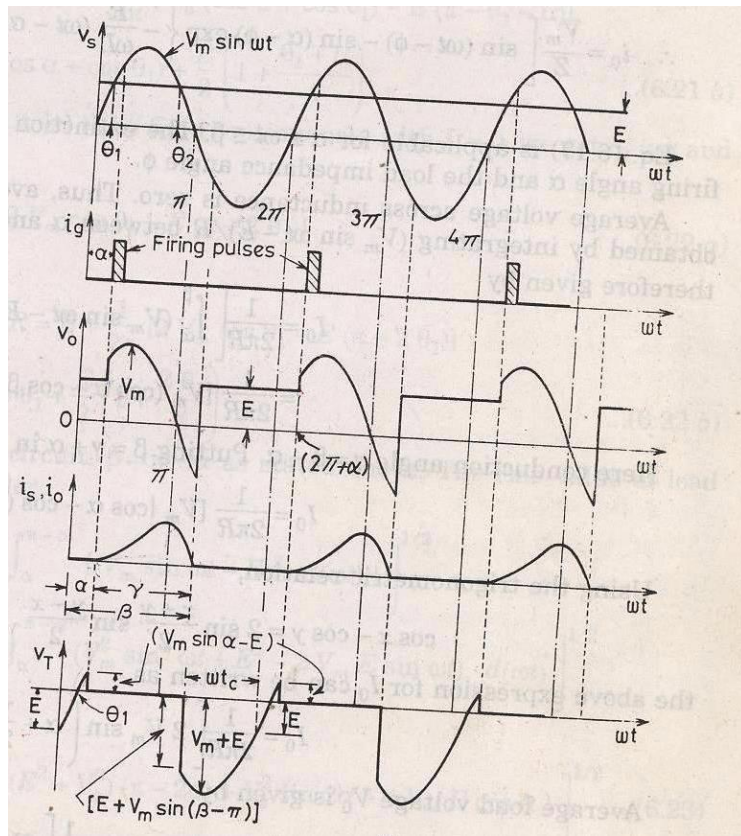

$$i_s = i_{s1} + i_{s2}$$

Due to source volt

$$i_{s1} = \frac{V_m}{Z} \sin(\omega t - \phi)$$

Due to DC counter emf

$$i_{s2} = -(E/R)$$

$$i_t = Ae^{-(R/L)t}$$

Thus the total current is given by

$$i_{s1} + i_{s2} + i_t$$

$$= \frac{V_m}{Z} \sin(\omega t - \phi) - \frac{E}{R} + Ae^{-(R/L)t}$$

$$i_{s0} = \frac{V_m}{Z} \sin(\omega t - \phi) - \frac{E}{R} + Ae^{-(R/L)t}$$

$$\text{At } \omega t = \alpha, i_0 = 0$$

$$A = \left[\frac{E}{R} - \frac{V_m}{Z} \sin(\alpha - \phi) \right] e^{-R\alpha/L\omega}$$

So

$$i_0 = \frac{V_m}{Z} \left[\sin(\omega t - \phi) - \sin(\alpha - \phi) e^{\left\{ \frac{-R}{\omega L} (\omega t - \alpha) \right\}} - \frac{E}{R} \left[1 - e^{\left\{ \frac{-R}{\omega L} (\omega t - \alpha) \right\}} \right] \right]$$

Average voltage across the inductance is zero. Average value of load current is

$$I_0 = \frac{1}{2\pi R} \int_{\alpha}^{\beta} (V_m \sin \omega t - E) d(\omega t)$$

$$= \frac{1}{2\pi R} [V_m (\cos \alpha - \cos \beta) - E(\beta - \alpha)]$$

Conduction angle $\nu = \beta - \alpha$

$$\Rightarrow \beta = \alpha + \nu$$

$$I_0 = \frac{1}{2\pi R} [V_m (\cos \alpha - \cos(\alpha + \nu)) - E(\nu)]$$

$$\cos A - \cos B = 2 \sin \frac{A+B}{2} \sin \frac{A-B}{2}$$

So

$$I_0 = \frac{1}{2\pi R} \left[2V_m \sin\left(\alpha + \frac{\nu}{2}\right) \sin \frac{\nu}{2} - E\nu \right]$$

$$v = E + I_0 R$$

$$= E + \frac{1}{2\pi} [2V_m \sin(\alpha + \frac{v}{2}) \sin \frac{v}{2} - E.v]$$

$$= E(1 - \frac{v}{2\pi}) + [\frac{V_m}{\pi} \sin(\alpha + \frac{v}{2}) \sin \frac{v}{2}]$$

If load inductance L is zero then

$$\beta = \theta_2$$

$$\text{And } v = \beta - \alpha = \theta_2 - \alpha$$

$$\text{But } \theta_2 = \pi - \theta_1$$

$$\text{So } \beta = \theta_2 = \pi - \theta_1$$

$$\text{And } v = \pi - \theta_1 - \alpha$$

So average current will be

$$I_0 = \frac{1}{2\pi R} [V_m (\cos \alpha - \cos(\pi - \theta_1)) - E(\pi - \theta_1 - \alpha)]$$

$$\text{So } V_0 = E + I_0 R$$

$$= \frac{V_m}{2\pi} (\cos \alpha + \cos \theta_1) + \frac{E}{2} (1 + \frac{\theta_1 + \alpha}{\pi})$$

For no inductance rms value of load current

$$I_0 = [\frac{1}{2\pi R^2} \int_{\alpha}^{\pi - \alpha} (V_m \sin(\omega t) - E)^2 d(\omega t)]^{1/2}$$

Power delivered to load

$$P = I_{or}^2 R + I_0 E$$

Supply power factor

$$Pf = \frac{I_{or}^2 R + I_0 E}{V_s I_{or}}$$

Single phase full wave converter:

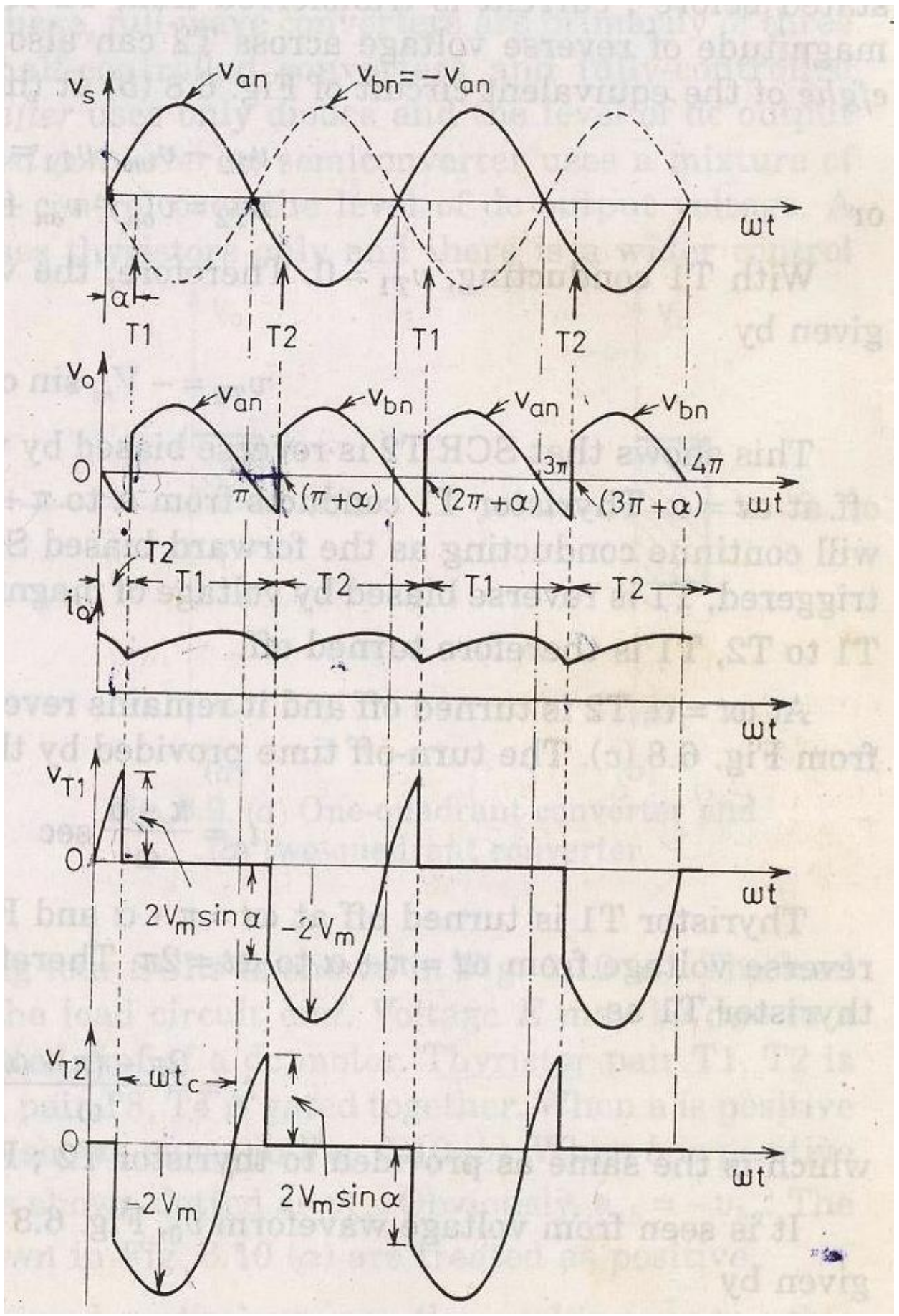

$$V_0 = \frac{1}{\pi} \int_{\alpha}^{\pi+\alpha} V_m \sin(\omega t) d(\omega t)$$

$$= \frac{2V_m}{\pi} \sin \alpha$$

Single phase semi converter:

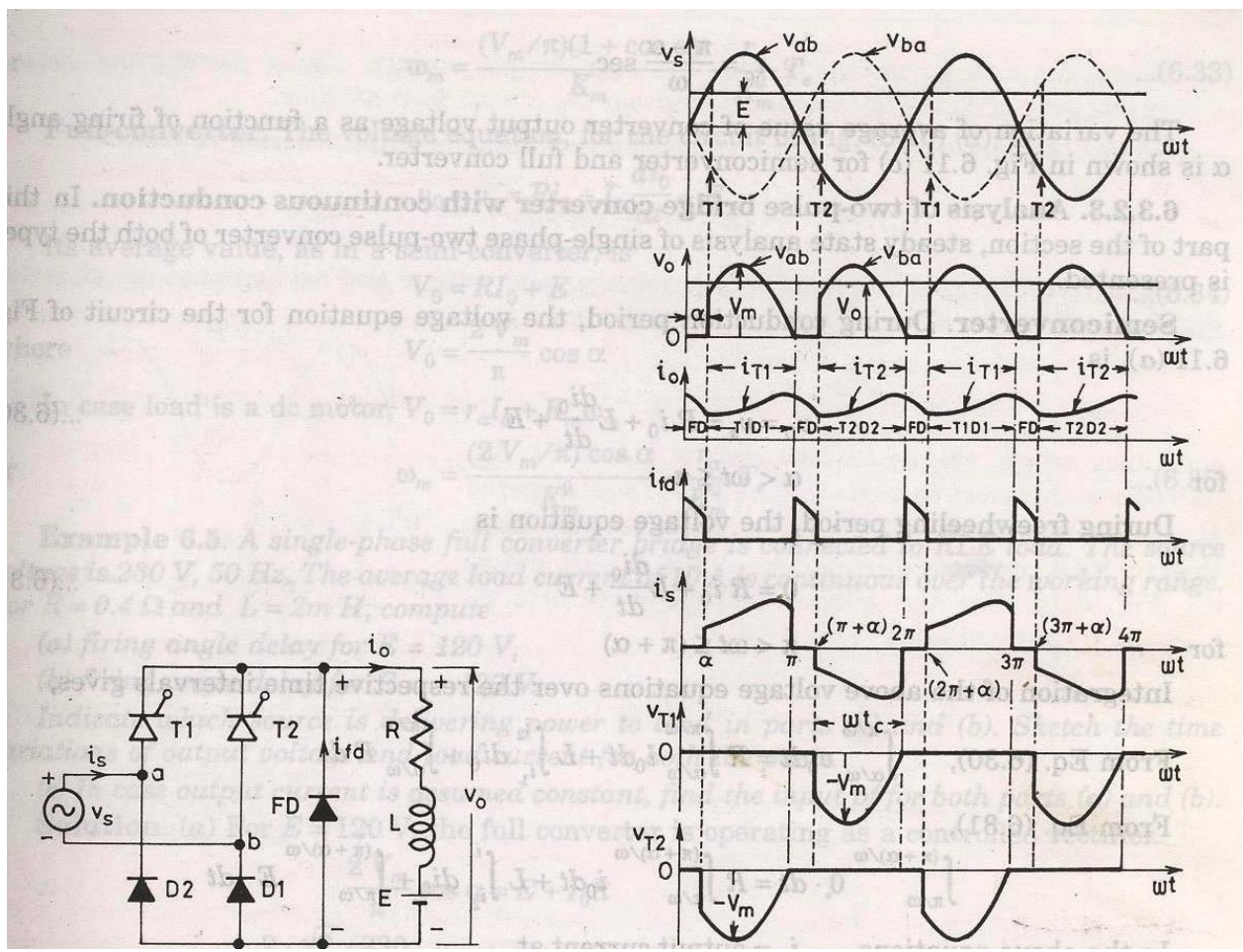

$$V_0 = \frac{1}{\pi} \int_{\alpha}^{\pi} V_m \sin(\omega t) d(\omega t)$$

$$= \frac{V_m}{\pi} \cos \alpha$$

full converter:

steady state analysis

$$V_s = Ri_o + L \frac{di_o}{dt} + E$$

$$V_0 = RI_0 + E$$

$$V_0 = \frac{2V_m}{\pi} \cos \alpha$$

So in case of DC motor load

$$V_0 = r_a I_a + \alpha_m \omega_m$$

$$\omega_m = \frac{\frac{2V_m}{\pi} \cos \alpha - r_a I_a}{\alpha_m}$$

So

$$T = \alpha_m I_a$$

$$\Rightarrow I_a = \frac{T_e}{\alpha_m}$$

$$I_a = \frac{T_e}{\alpha_m}$$

Put

$$\omega_m = \frac{(\frac{2V_m}{\pi}) \cos \alpha}{\alpha_m} - \frac{r_a T_e}{\alpha_m^2}$$

So

THREE PHASE CONTROLLED RECTIFIERS

Single phase half controlled bridge converters & fully controlled bridge converters are used extensively in industrial applications up to about 15kW of output power. The single phase controlled rectifiers provide a maximum dc output of $V_{dc(max)} = \frac{2V_m}{\pi}$.

The output ripple frequency is equal to the twice the ac supply frequency. The single phase full wave controlled rectifiers provide two output pulses during every input supply cycle and hence are referred to as two pulse converters.

Three phase converters are 3-phase controlled rectifiers which are used to convert ac input power supply into dc output power across the load.

Features of 3-phase controlled rectifiers are

- Operate from 3 phase ac supply voltage.
- They provide higher dc output voltage and higher dc output power.
- Higher output voltage ripple frequency.
- Filtering requirements are simplified for smoothing out load voltage and load current

Three phase controlled rectifiers are extensively used in high power variable speed industrial dc drives.

3-PHASE HALF WAVE CONVERTER

Three single phase half-wave converters are connected together to form a three phase half-wave converter as shown in the figure.

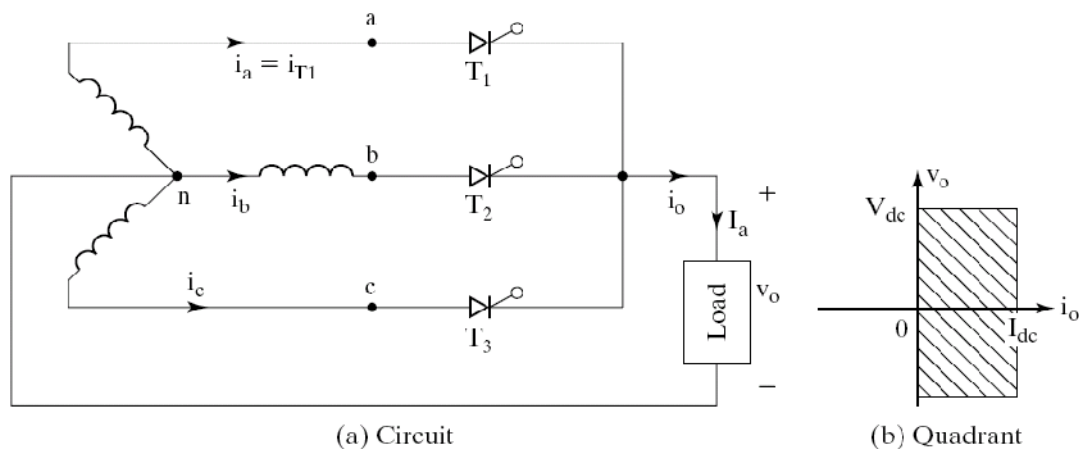

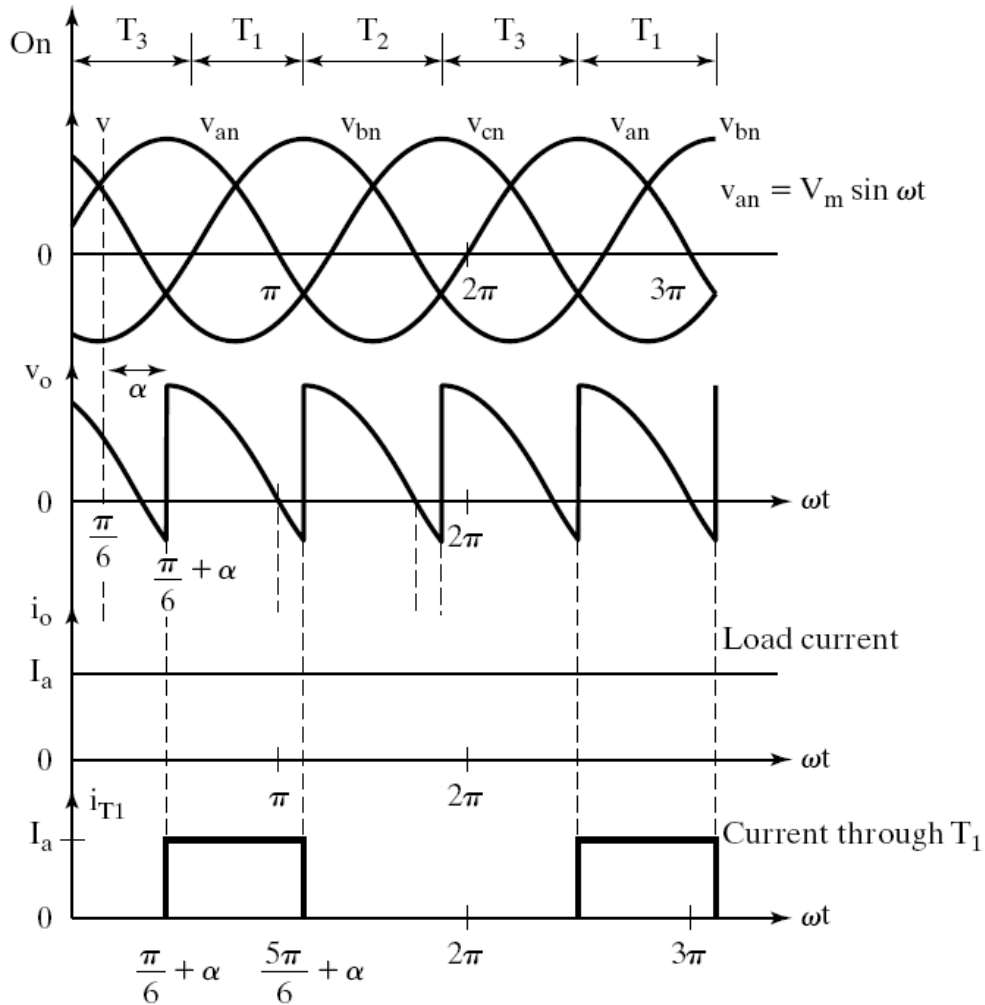

(c) For inductive load

THREE PHASE SUPPLY VOLTAGE EQUATIONS

We define three line neutral voltages (3 phase voltages) as follows

$$v_{RN} = v_{an} = V_m \sin \omega t; \quad V_m = \text{Max. Phase Voltage}$$

$$v_{YN} = v_{bn} = V_m \sin \left(\omega t - \frac{2\pi}{3} \right)$$

$$v_{YN} = v_{bn} = V_m \sin (\omega t - 120^\circ)$$

$$v_{BN} = v_{cn} = V_m \sin \left(\omega t + \frac{2\pi}{3} \right)$$

$$v_{BN} = v_{cn} = V_m \sin (\omega t + 120^\circ)$$

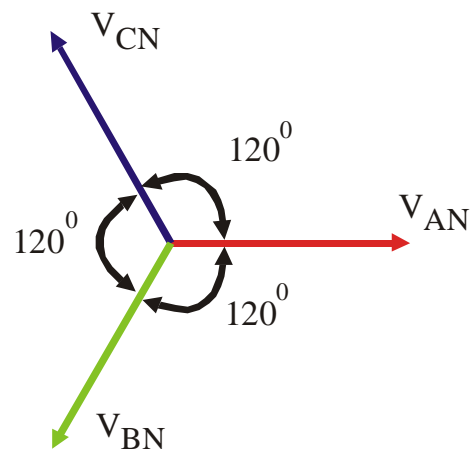

Vector diagram of 3-phase supply voltages

$$v_{BN} = v_{cn} = V_m \sin(\omega t - 240^\circ)$$

The 3-phase half wave converter combines three single phase half wave controlled rectifiers in one single circuit feeding a common load. The thyristor T_1 in series with one of the supply phase windings 'a-n' acts as one half wave controlled rectifier. The second thyristor T_2 in series with the supply phase winding 'b-n' acts as the second half wave controlled rectifier. The third thyristor T_3 in series with the supply phase winding 'c-n' acts as the third half wave controlled rectifier.

The 3-phase input supply is applied through the star connected supply transformer as shown in the figure. The common neutral point of the supply is connected to one end of the load while the other end of the load connected to the common cathode point.

When the thyristor T_1 is triggered at $\omega t = \left(\frac{\pi}{6} + \alpha\right) = (30^\circ + \alpha)$, the phase voltage v_{an} appears across the load when T_1 conducts. The load current flows through the supply phase winding 'a-n' and through thyristor T_1 as long as T_1 conducts.

When thyristor T_2 is triggered at $\omega t = \left(\frac{5\pi}{6} + \alpha\right) = (150^\circ + \alpha)$, T_1 becomes reverse biased and turns-off. The load current flows through the thyristor T_2 and through the supply phase winding 'b-n'. When T_2 conducts the phase voltage v_{bn} appears across the load until the thyristor T_3 is triggered.

When the thyristor T_3 is triggered at $\omega t = \left(\frac{3\pi}{2} + \alpha\right) = (270^\circ + \alpha)$, T_2 is reversed biased and hence T_2 turns-off. The phase voltage v_{cn} appears across the load when T_3 conducts.

When T_1 is triggered again at the beginning of the next input cycle the thyristor T_3 turns off as it is reverse biased naturally as soon as T_1 is triggered. The figure shows the 3-phase input supply voltages, the output voltage which appears across the load, and the load current assuming a constant and ripple free load current for a highly inductive load and the current through the thyristor T_1 .

For a purely resistive load where the load inductance 'L = 0' and the trigger angle $\alpha > \left(\frac{\pi}{6}\right)$, the load current appears as discontinuous load current and each thyristor is naturally commutated when the polarity of the corresponding phase supply voltage reverses. The frequency of output ripple frequency for a 3-phase half wave converter is $3f_s$, where f_s is the input supply frequency.

The 3-phase half wave converter is not normally used in practical converter systems because of the disadvantage that the supply current waveforms contain dc components (i.e., the supply current waveforms have an average or dc value).

TO DERIVE AN EXPRESSION FOR THE AVERAGE OUTPUT VOLTAGE OF A 3-PHASE HALF WAVE CONVERTER FOR CONTINUOUS LOAD CURRENT

The reference phase voltage is $v_{RN} = v_{an} = V_m \sin \omega t$. The trigger angle α is measured from the cross over points of the 3-phase supply voltage waveforms. When the phase supply voltage v_{an} begins its positive half cycle at $\omega t = 0$, the first cross over point appears at

$$\omega t = \left(\frac{\pi}{6}\right) \text{ radians} = 30^\circ.$$

The trigger angle α for the thyristor T_1 is measured from the cross over point at $\omega t = 30^\circ$. The thyristor T_1 is forward biased during the period $\omega t = 30^\circ$ to 150° , when the phase supply voltage v_{an} has a higher amplitude than the other phase supply voltages. Hence T_1 can be triggered between 30° to 150° . When the thyristor T_1 is triggered at a trigger angle α , the average or dc output voltage for continuous load current is calculated using the equation

$$V_{dc} = \frac{3}{2\pi} \left[\int_{\frac{\pi}{6} + \alpha}^{\frac{5\pi}{6} + \alpha} v_o \cdot d(\omega t) \right]$$

Output voltage $v_o = v_{an} = V_m \sin \omega t$ for $\omega t = (30^\circ + \alpha)$ to $(150^\circ + \alpha)$

$$V_{dc} = \frac{3}{2\pi} \left[\int_{\frac{\pi}{6} + \alpha}^{\frac{5\pi}{6} + \alpha} V_m \sin \omega t \cdot d(\omega t) \right]$$

As the output load voltage waveform has three output pulses during the input cycle of 2π radians

$$V_{dc} = \frac{3V_m}{2\pi} \left[\int_{\frac{\pi}{6} + \alpha}^{\frac{5\pi}{6} + \alpha} \sin \omega t \cdot d(\omega t) \right]$$

$$V_{dc} = \frac{3V_m}{2\pi} \left[\frac{-\cos \omega t}{\frac{\pi}{6} + \alpha} \right]_{\frac{\pi}{6} + \alpha}^{\frac{5\pi}{6} + \alpha}$$

$$V_{dc} = \frac{3V_m}{2\pi} \left[-\cos \left(\frac{5\pi}{6} + \alpha \right) + \cos \left(\frac{\pi}{6} + \alpha \right) \right]$$

Note from the trigonometric relationship

$$\cos(A + B) = (\cos A \cdot \cos B - \sin A \cdot \sin B)$$

$$V_{dc} = \frac{3V_m}{2\pi} \left[-\cos \left(\frac{5\pi}{6} \right) \cos(\alpha) + \sin \left(\frac{5\pi}{6} \right) \sin(\alpha) + \cos \left(\frac{\pi}{6} \right) \cdot \cos(\alpha) - \sin \left(\frac{\pi}{6} \right) \sin(\alpha) \right]$$

$$V_{dc} = \frac{3V_m}{2\pi} \left[-\cos(150^\circ) \cos(\alpha) + \sin(150^\circ) \sin(\alpha) + \cos(30^\circ) \cdot \cos(\alpha) - \sin(30^\circ) \sin(\alpha) \right]$$

$$V_{dc} = \frac{3V_m}{2\pi} \left[-\cos(180^\circ - 30^\circ) \cos(\alpha) + \sin(180^\circ - 30^\circ) \sin(\alpha) + \cos(30^\circ) \cdot \cos(\alpha) - \sin(30^\circ) \sin(\alpha) \right]$$

Note: $\cos(180^\circ - 30^\circ) = -\cos(30^\circ)$

$$\sin(180^\circ - 30^\circ) = \sin(30^\circ)$$

Therefore

$$V_{dc} = \frac{3V_m}{2\pi} \left[+\cos(30^\circ) \cos(\alpha) + \sin(30^\circ) \sin(\alpha) + \cos(30^\circ) \cdot \cos(\alpha) - \sin(30^\circ) \sin(\alpha) \right]$$

$$V_{dc} = \frac{3V_m}{2\pi} \left[2 \cos(30^\circ) \cos(\alpha) \right]$$

$$V_{dc} = \frac{3V_m}{2\pi} \left[2 \times \frac{\sqrt{3}}{2} \cos(\alpha) \right]$$

$$V_{dc} = \frac{3V_m}{2\pi} \left[\sqrt{3} \cos(\alpha) \right] = \frac{3\sqrt{3}V_m}{2\pi} \cos(\alpha)$$

$$V_{dc} = \frac{3V_{Lm}}{2\pi} \cos(\alpha)$$

Where

$V_{Lm} = \sqrt{3}V_m = \text{Max. line to line supply voltage for a 3-phase star connected transformer.}$

The maximum average or dc output voltage is obtained at a delay angle $\alpha = 0$ and is given by

$$V_{dc(\max)} = V_{dm} = \frac{3\sqrt{3} V_m}{2\pi} \text{ Where } V_m \text{ is the peak phase voltage.}$$

And the normalized average output voltage is $V_{dcn} = V_n = \frac{V_{dc}}{V_{dm}} = \cos \alpha$

TO DERIVE AN EXPRESSION FOR THE RMS VALUE OF THE OUTPUT VOLTAGE OF A 3-PHASE HALF WAVE CONVERTER FOR CONTINUOUS LOAD CURRENT

The rms value of output voltage is found by using the equation

$$V_{O(RMS)} = \left[\frac{3}{2\pi} \int_{\frac{\pi}{6} + \alpha}^{\frac{5\pi}{6} + \alpha} V_m^2 \sin^2 \omega t . d(\omega t) \right]^{\frac{1}{2}}$$

and we obtain $V_{O(RMS)} = \sqrt{3}V_m \left[\frac{1}{6} + \frac{\sqrt{3}}{8\pi} \cos 2\alpha \right]^{\frac{1}{2}}$

3 PHASE HALF WAVE CONTROLLED RECTIFIER OUTPUT VOLTAGE WAVEFORMS FOR DIFFERENT TRIGGER ANGLES WITH RL LOAD

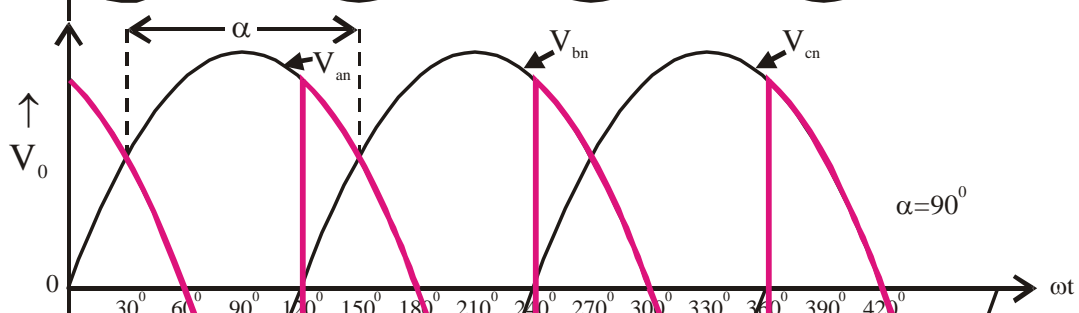
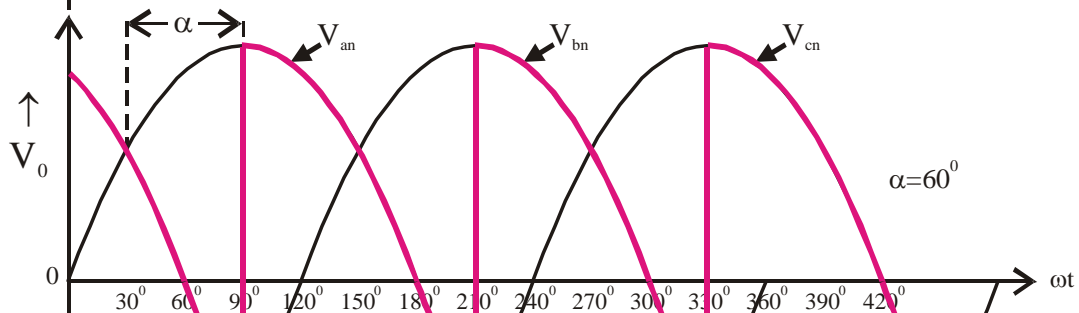
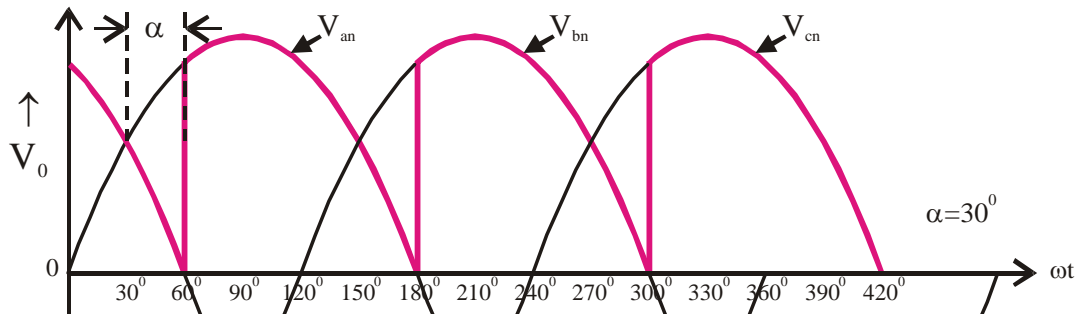

3 PHASE HALF WAVE CONTROLLED RECTIFIER OUTPUT VOLTAGE WAVEFORMS FOR DIFFERENT TRIGGER ANGLES WITH R LOAD

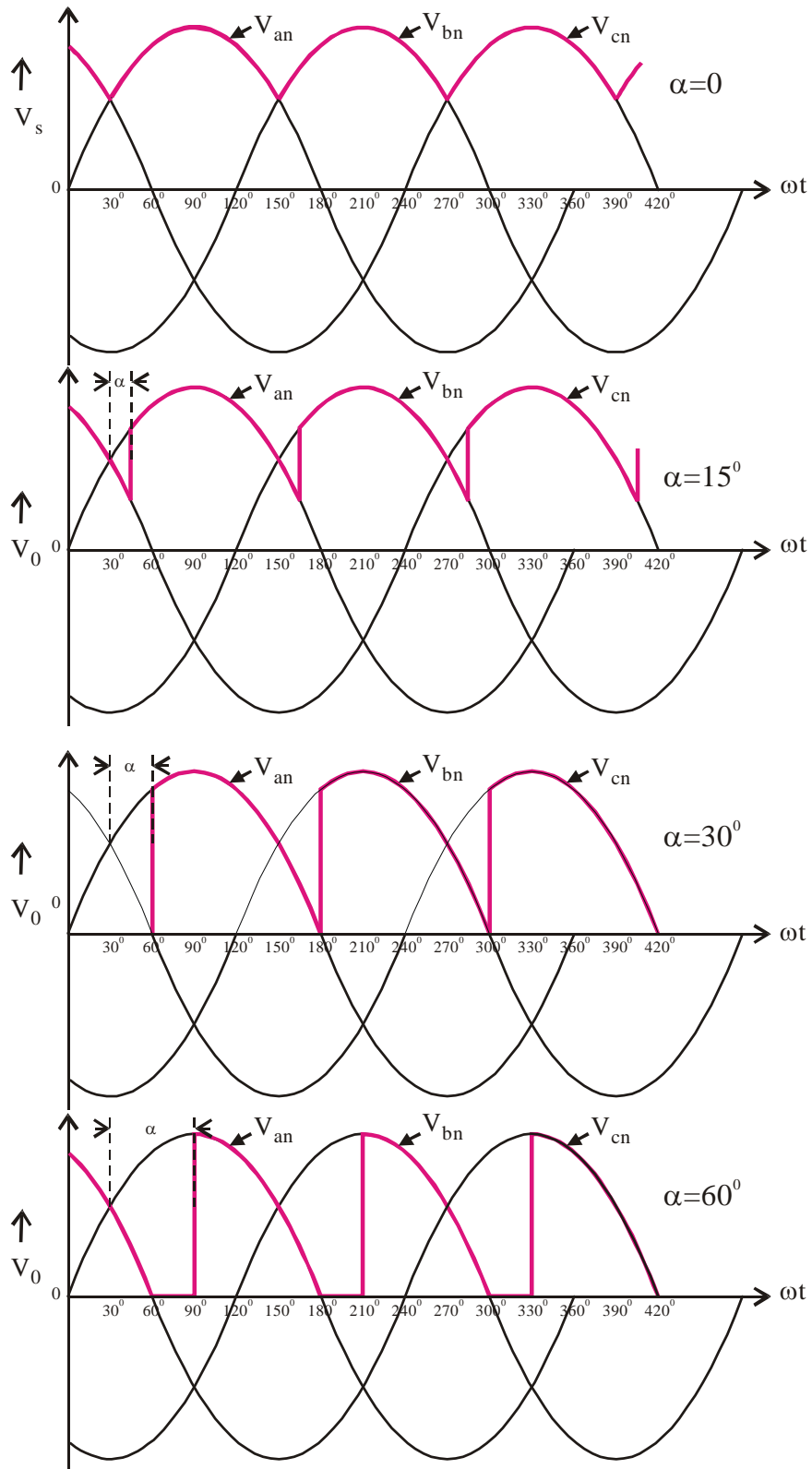

TO DERIVE AN EXPRESSION FOR THE AVERAGE OR DC OUTPUT VOLTAGE OF A 3 PHASE HALF WAVE CONVERTER WITH RESISTIVE LOAD OR RL LOAD WITH FWD.

In the case of a three-phase half wave controlled rectifier with resistive load, the thyristor T_1 is triggered at $\omega t = (30^\circ + \alpha)$ and T_1 conducts up to $\omega t = 180^\circ = \pi$ radians. When the phase supply voltage v_{an} decreases to zero at $\omega t = \pi$, the load current falls to zero and the thyristor T_1 turns off. Thus T_1 conducts from $\omega t = (30^\circ + \alpha)$ to (180°) .

Hence the average dc output voltage for a 3-pulse converter (3-phase half wave controlled rectifier) is calculated by using the equation

$$V_{dc} = \frac{3}{2\pi} \left[\int_{\alpha+30^\circ}^{180^\circ} v_o \cdot d(\omega t) \right]$$

$$v_o = v_{an} = V_m \sin \omega t; \text{ for } \omega t = (\alpha + 30^\circ) \text{ to } (180^\circ)$$

$$V_{dc} = \frac{3}{2\pi} \left[\int_{\alpha+30^\circ}^{180^\circ} V_m \sin \omega t \cdot d(\omega t) \right]$$

$$V_{dc} = \frac{3V_m}{2\pi} \left[\int_{\alpha+30^\circ}^{180^\circ} \sin \omega t \cdot d(\omega t) \right]$$

$$V_{dc} = \frac{3V_m}{2\pi} \left[-\cos \omega t \Big/_{\alpha+30^\circ}^{180^\circ} \right]$$

$$V_{dc} = \frac{3V_m}{2\pi} \left[-\cos 180^\circ + \cos(\alpha + 30^\circ) \right]$$

Since $\cos 180^\circ = -1$,

We get
$$V_{dc} = \frac{3V_m}{2\pi} \left[1 + \cos(\alpha + 30^\circ) \right]$$

THREE PHASE SEMICONVERTERS

3-phase semi-converters are three phase half controlled bridge controlled rectifiers which employ three thyristors and three diodes connected in the form of a bridge configuration. Three thyristors are controlled switches which are turned on at appropriate times by applying

appropriate gating signals. The three diodes conduct when they are forward biased by the corresponding phase supply voltages.

3-phase semi-converters are used in industrial power applications up to about 120kW output power level, where single quadrant operation is required. The power factor of 3-phase semi-converter decreases as the trigger angle α increases. The power factor of a 3-phase semi-converter is better than three phase half wave converter.

The figure shows a 3-phase semi-converter with a highly inductive load and the load current is assumed to be a constant and continuous load current with negligible ripple.

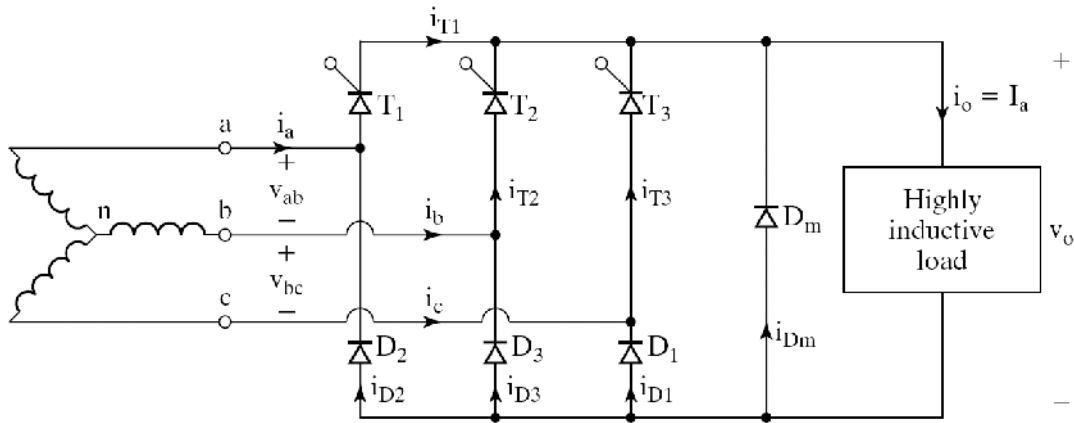

Thyristor T_1 is forward biased when the phase supply voltage v_{an} is positive and greater than the other phase voltages v_{bn} and v_{cn} . The diode D_1 is forward biased when the phase supply voltage v_{cn} is more negative than the other phase supply voltages.

Thyristor T_2 is forward biased when the phase supply voltage v_{bn} is positive and greater than the other phase voltages. Diode D_2 is forward biased when the phase supply voltage v_{an} is more negative than the other phase supply voltages.

Thyristor T_3 is forward biased when the phase supply voltage v_{cn} is positive and greater than the other phase voltages. Diode D_3 is forward biased when the phase supply voltage v_{bn} is more negative than the other phase supply voltages.

The figure shows the waveforms for the three phase input supply voltages, the output voltage, the thyristor and diode current waveforms, the current through the free wheeling diode D_m and the supply current i_a . The frequency of the output supply waveform is $3f_s$, where f_s is the input ac supply frequency. The trigger angle α can be varied from 0° to 180° .

During the time period $\left(\frac{\pi}{6}\right) \leq \omega t \leq \left(\frac{7\pi}{6}\right)$ i.e., for $30^\circ \leq \omega t \leq 210^\circ$, thyristor T_1 is forward biased. If T_1 is triggered at $\omega t = \left(\frac{\pi}{6} + \alpha\right)$, T_1 and D_1 conduct together and the line to line supply voltage v_{ac} appears across the load. At $\omega t = \left(\frac{7\pi}{6}\right)$, v_{ac} starts to become negative and the free wheeling diode D_m turns on and conducts. The load current continues to flow through the free wheeling diode D_m and thyristor T_1 and diode D_1 are turned off.

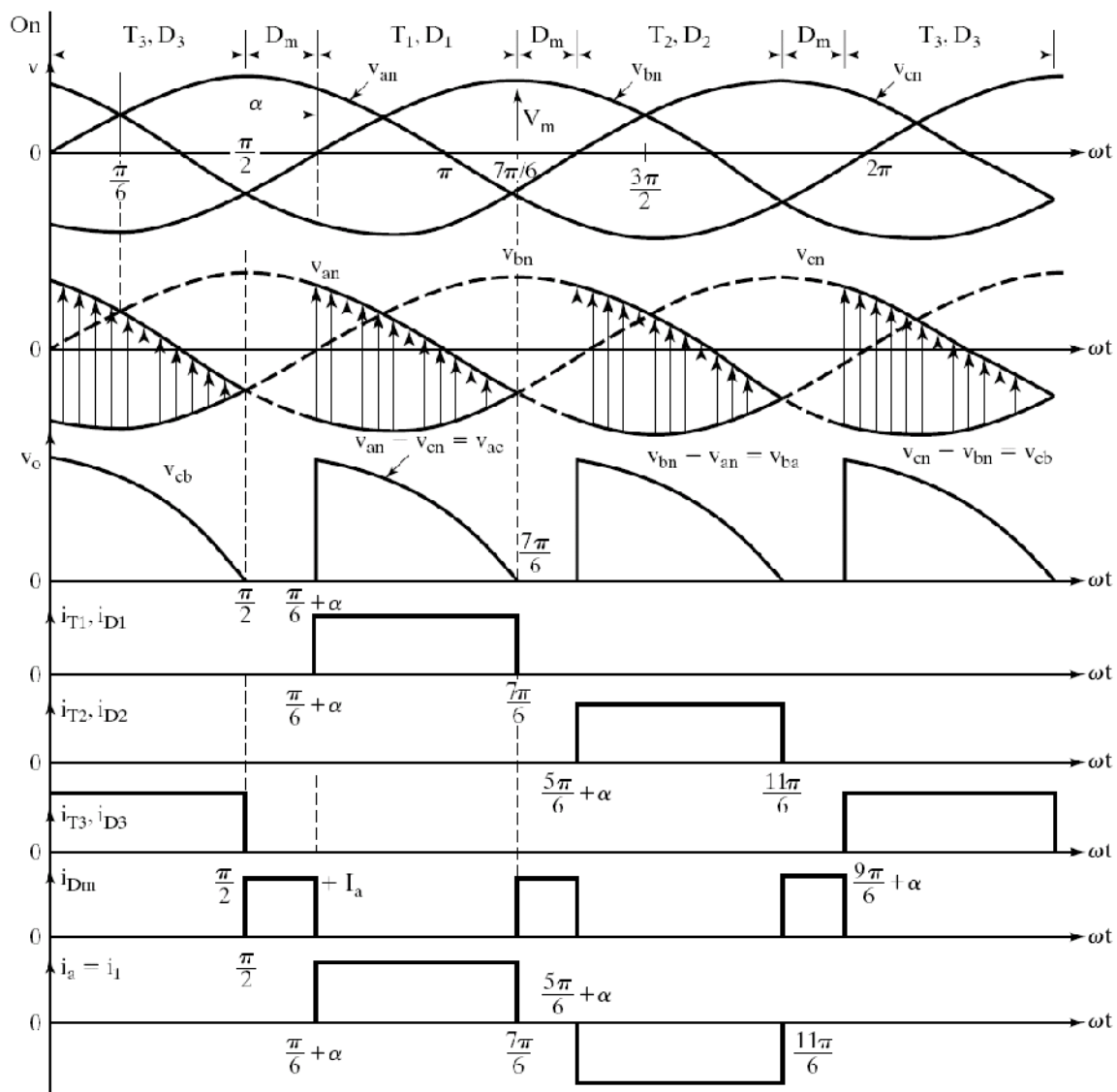

(b) Waveforms for $\alpha = 90^\circ$

If the free wheeling diode D_m is not connected across the load, then T_1 would continue to conduct until the thyristor T_2 is triggered at $\omega t = \left(\frac{5\pi}{6} + \alpha\right)$ and the free wheeling action is accomplished through T_1 and D_2 , when D_2 turns on as soon as v_{an} becomes more negative at $\omega t = \left(\frac{7\pi}{6}\right)$. If the trigger angle $\alpha \leq \left(\frac{\pi}{3}\right)$ each thyristor conducts for $\frac{2\pi}{3}$ radians (120°) and the free wheeling diode D_m does not conduct. The waveforms for a 3-phase semi-converter with $\alpha \leq \left(\frac{\pi}{3}\right)$ is shown in figure

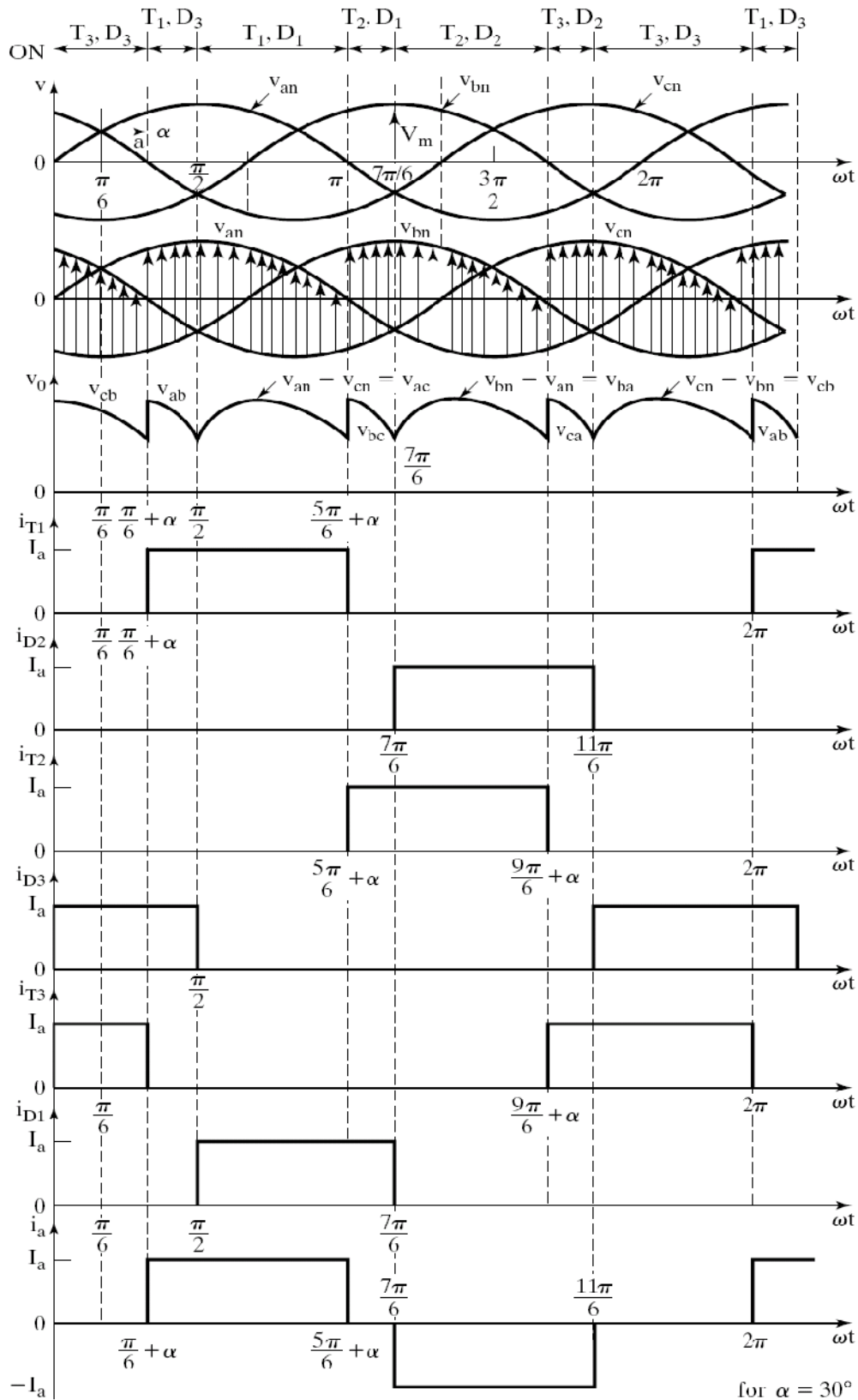

We define three line neutral voltages (3 phase voltages) as follows

$$v_{RN} = v_{an} = V_m \sin \omega t; \quad V_m = \text{Max. Phase Voltage}$$

$$v_{YN} = v_{bn} = V_m \sin \left(\omega t - \frac{2\pi}{3} \right), \quad v_{YN} = v_{bn} = V_m \sin \left(\omega t - 120^\circ \right), \quad v_{BN} = v_{cn} = V_m \sin \left(\omega t + \frac{2\pi}{3} \right)$$

$$v_{BN} = v_{cn} = V_m \sin \left(\omega t + 120^\circ \right), \quad v_{BN} = v_{cn} = V_m \sin \left(\omega t - 240^\circ \right)$$

The corresponding line-to-line voltages are

$$v_{RB} = v_{ac} = (v_{an} - v_{cn}) = \sqrt{3}V_m \sin \left(\omega t - \frac{\pi}{6} \right), \quad v_{YR} = v_{ba} = (v_{bn} - v_{an}) = \sqrt{3}V_m \sin \left(\omega t - \frac{5\pi}{6} \right)$$

$$v_{BY} = v_{cb} = (v_{cn} - v_{bn}) = \sqrt{3}V_m \sin \left(\omega t + \frac{\pi}{2} \right), \quad v_{RY} = v_{ab} = (v_{an} - v_{bn}) = \sqrt{3}V_m \sin \left(\omega t + \frac{\pi}{6} \right)$$

Where V_m is the peak phase voltage of a star (Y) connected source.

TO DERIVE AN EXPRESSION FOR THE AVERAGE OUTPUT VOLTAGE OF THREE PHASE SEMICONVERTER FOR $\alpha > \left(\frac{\pi}{3} \right)$ AND DISCONTINUOUS OUTPUT VOLTAGE

For $\alpha \geq \frac{\pi}{3}$ and discontinuous output voltage: the average output voltage is found from

$$V_{dc} = \frac{3}{2\pi} \int_{\pi/6+\alpha}^{7\pi/6} v_{ac} \cdot d(\omega t), \quad V_{dc} = \frac{3}{2\pi} \int_{\pi/6+\alpha}^{7\pi/6} \sqrt{3} V_m \sin \left(\omega t - \frac{\pi}{6} \right) d(\omega t)$$

$$V_{dc} = \frac{3\sqrt{3}V_m}{2\pi} (1 + \cos \alpha)$$

$$V_{dc} = \frac{3V_{mL}}{2\pi} (1 + \cos \alpha)$$

The maximum average output voltage that occurs at a delay angle of $\alpha = 0$ is

$$V_{dm} = \frac{3\sqrt{3}V_m}{\pi}$$

The normalized average output voltage is

$$V_n = \frac{V_{dc}}{V_{dm}} = 0.5(1 + \cos \alpha)$$

The rms output voltage is found from

$$V_{O(RMS)} = \left[\frac{3}{2\pi} \int_{\pi/6+\alpha}^{7\pi/6} 3V_m^2 \sin^2 \left(\omega t - \frac{\pi}{6} \right) d(\omega t) \right]^{\frac{1}{2}}$$

$$V_{O(RMS)} = \sqrt{3}V_m \left[\frac{3}{4\pi} \left(\pi - \alpha + \frac{1}{2} \sin 2\alpha \right) \right]^{\frac{1}{2}}$$

For $\alpha \leq \frac{\pi}{3}$, and continuous output voltage

Output voltage $v_o = v_{ab} = \sqrt{3}V_m \sin \left(\omega t + \frac{\pi}{6} \right)$; for $\omega t = \left(\frac{\pi}{6} + \alpha \right)$ to $\left(\frac{\pi}{2} \right)$

Output voltage $v_o = v_{ac} = \sqrt{3}V_m \sin \left(\omega t - \frac{\pi}{6} \right)$; for $\omega t = \left(\frac{\pi}{2} \right)$ to $\left(\frac{5\pi}{6} + \alpha \right)$

The average or dc output voltage is calculated by using the equation

$$V_{dc} = \frac{3}{2\pi} \left[\int_{\pi/6+\alpha}^{\pi/2} v_{ab} \cdot d(\omega t) + \int_{\pi/2}^{5\pi/6+\alpha} v_{ac} \cdot d(\omega t) \right]$$

$$V_{dc} = \frac{3\sqrt{3}V_m}{2\pi} (1 + \cos \alpha)$$

$$V_n = \frac{V_{dc}}{V_{dm}} = 0.5(1 + \cos \alpha)$$

The RMS value of the output voltage is calculated by using the equation

$$V_{O(RMS)} = \left[\frac{3}{2\pi} \int_{\pi/6+\alpha}^{\pi/2} v_{ab}^2 \cdot d(\omega t) + \int_{\pi/2}^{5\pi/6+\alpha} v_{ac}^2 \cdot d(\omega t) \right]^{\frac{1}{2}}$$

$$V_{O(RMS)} = \sqrt{3}V_m \left[\frac{3}{4\pi} \left(\frac{2\pi}{3} + \sqrt{3} \cos^2 \alpha \right) \right]^{\frac{1}{2}}$$

THREE PHASE FULL CONVERTER

Three phase full converter is a fully controlled bridge controlled rectifier using six thyristors connected in the form of a full wave bridge configuration. All the six thyristors are controlled switches which are turned on at a appropriate times by applying suitable gate trigger signals. The three phase full converter is extensively used in industrial power applications upto about 120kW output power level, where two quadrant operation is required. The figure shows a

three phase full converter with highly inductive load. This circuit is also known as three phase full wave bridge or as a six pulse converter. The thyristors are triggered at an interval of $\left(\frac{\pi}{3}\right)$ radians (i.e. at an interval of 60°). The frequency of output ripple voltage is $6f_s$ and the filtering requirement is less than that of three phase semi and half wave converters.

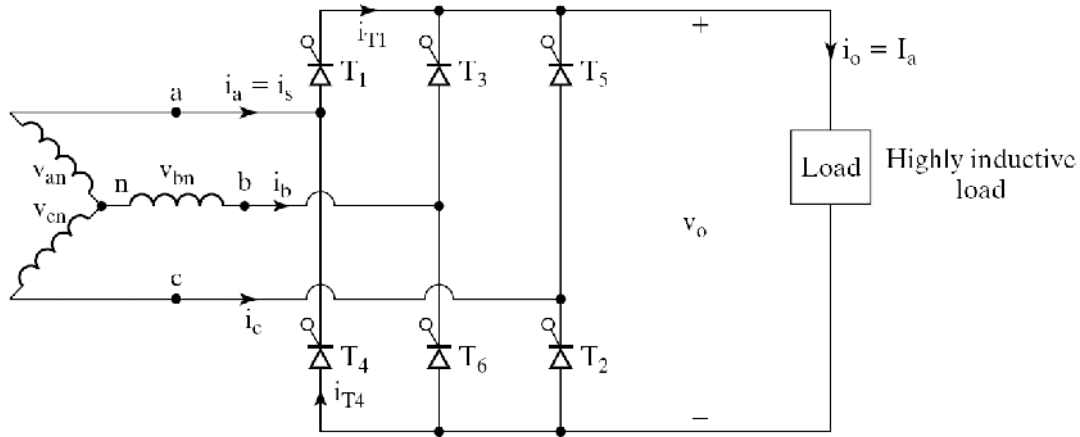

At $\omega t = \left(\frac{\pi}{6} + \alpha\right)$, thyristor T_6 is already conducting when the thyristor T_1 is turned on by applying the gating signal to the gate of T_1 . During the time period $\omega t = \left(\frac{\pi}{6} + \alpha\right)$ to $\left(\frac{\pi}{2} + \alpha\right)$, thyristors T_1 and T_6 conduct together and the line to line supply voltage v_{ab} appears across the load. At $\omega t = \left(\frac{\pi}{2} + \alpha\right)$, the thyristor T_2 is triggered and T_6 is reverse biased immediately and T_6 turns off due to natural commutation. During the time period $\omega t = \left(\frac{\pi}{2} + \alpha\right)$ to $\left(\frac{5\pi}{6} + \alpha\right)$, thyristor T_1 and T_2 conduct together and the line to line supply voltage v_{ac} appears across the load. The thyristors are numbered in the circuit diagram corresponding to the order in which they are triggered. The trigger sequence (firing sequence) of the thyristors is 12, 23, 34, 45, 56, 61, 12, 23, and so on. The figure shows the waveforms of three phase input supply voltages, output voltage, the thyristor current through T_1 and T_4 , the supply current through the line 'a'.

We define three line neutral voltages (3 phase voltages) as follows

$$v_{RN} = v_{an} = V_m \sin \omega t \quad ; \quad V_m = \text{Max. Phase Voltage}$$

$$v_{YN} = v_{bn} = V_m \sin \left(\omega t - \frac{2\pi}{3} \right) = V_m \sin(\omega t - 120^\circ),$$

$$v_{BN} = v_{cn} = V_m \sin \left(\omega t + \frac{2\pi}{3} \right) = V_m \sin(\omega t + 120^\circ) = V_m \sin(\omega t - 240^\circ)$$

Where V_m is the peak phase voltage of a star (Y) connected source.

The corresponding line-to-line voltages are

$$v_{RY} = v_{ab} = (v_{an} - v_{bn}) = \sqrt{3}V_m \sin \left(\omega t + \frac{\pi}{6} \right), \quad v_{YB} = v_{bc} = (v_{bn} - v_{cn}) = \sqrt{3}V_m \sin \left(\omega t - \frac{\pi}{2} \right)$$

$$v_{BR} = v_{ca} = (v_{cn} - v_{an}) = \sqrt{3}V_m \sin \left(\omega t + \frac{\pi}{2} \right)$$

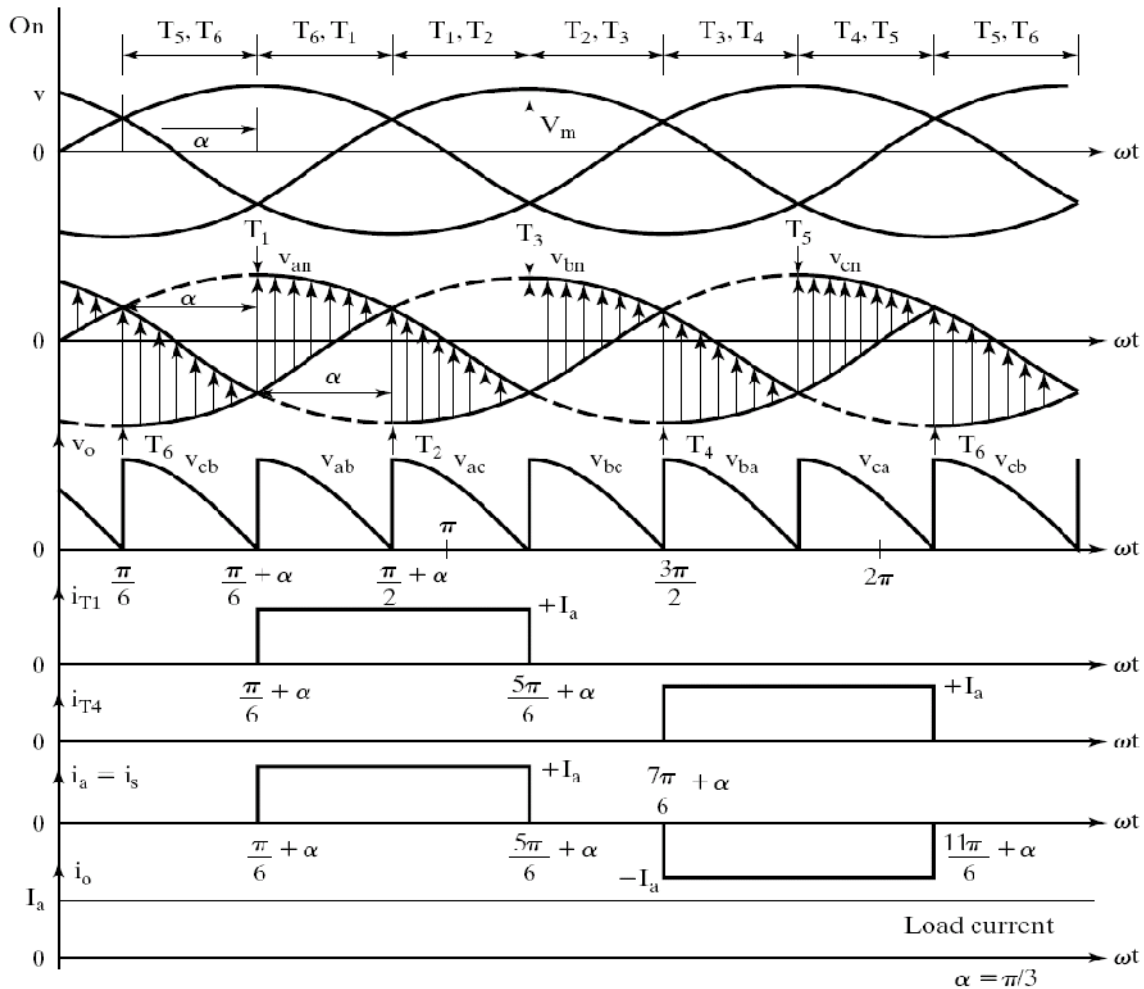

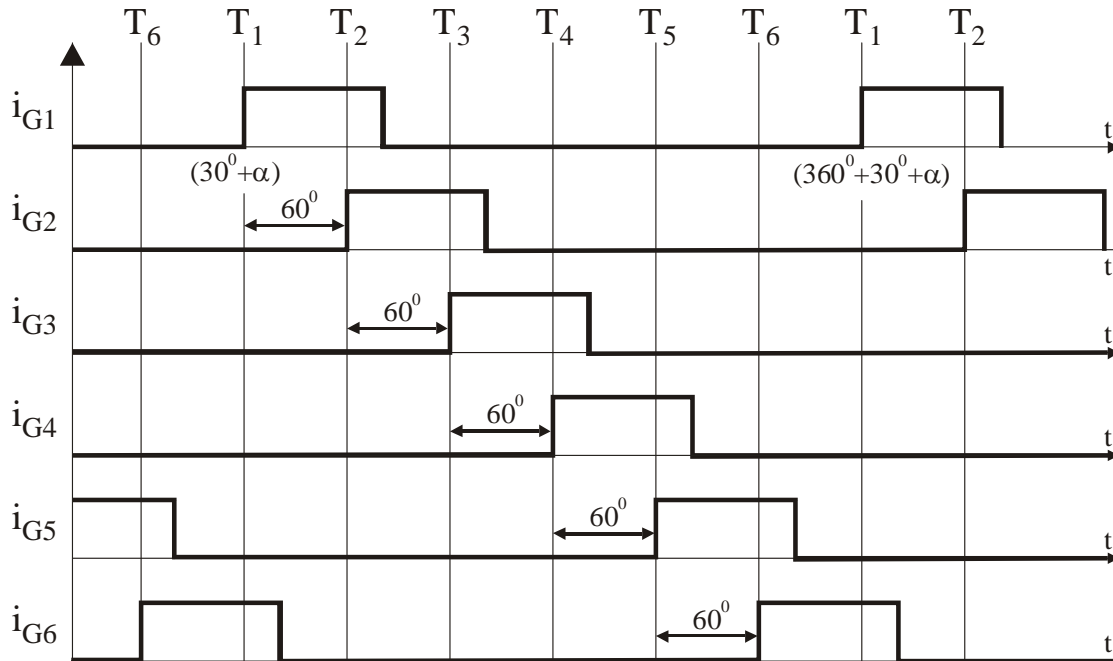

Gating (Control) Signals of 3-phase full converter

TO DERIVE AN EXPRESSION FOR THE AVERAGE OUTPUT VOLTAGE OF THREE PHASE FULL CONVERTER WITH HIGHLY INDUCTIVE LOAD ASSUMING CONTINUOUS AND CONSTANT LOAD CURRENT

The output load voltage consists of 6 voltage pulses over a period of 2π radians, hence the average output voltage is calculated as

$$V_{O(dc)} = V_{dc} = \frac{6}{2\pi} \int_{\frac{\pi}{6} + \alpha}^{\frac{\pi}{2} + \alpha} v_o \cdot d\omega t \quad ;$$

$$v_o = v_{ab} = \sqrt{3}V_m \sin\left(\omega t + \frac{\pi}{6}\right)$$

$$V_{dc} = \frac{3}{\pi} \int_{\frac{\pi}{6} + \alpha}^{\frac{\pi}{2} + \alpha} \sqrt{3}V_m \sin\left(\omega t + \frac{\pi}{6}\right) \cdot d\omega t$$

$$V_{dc} = \frac{3\sqrt{3}V_m}{\pi} \cos \alpha = \frac{3V_{mL}}{\pi} \cos \alpha$$

Where $V_{mL} = \sqrt{3}V_m = \text{Max. line-to-line supply voltage}$

The maximum average dc output voltage is obtained for a delay angle $\alpha = 0$,

$$V_{dc(\max)} = V_{dm} = \frac{3\sqrt{3}V_m}{\pi} = \frac{3V_{mL}}{\pi}$$

The normalized average dc output voltage is

$$V_{dcn} = V_n = \frac{V_{dc}}{V_{dm}} = \cos \alpha$$

The rms value of the output voltage is found from

$$V_{O(rms)} = \left[\frac{6}{2\pi} \int_{\frac{\pi}{6}}^{\frac{\pi}{2}+\alpha} v_o^2 \cdot d(\omega t) \right]^{\frac{1}{2}}$$

$$V_{O(rms)} = \left[\frac{6}{2\pi} \int_{\frac{\pi}{6}}^{\frac{\pi}{2}+\alpha} v_{ab}^2 \cdot d(\omega t) \right]^{\frac{1}{2}}$$

$$V_{O(rms)} = \left[\frac{3}{2\pi} \int_{\frac{\pi}{6}}^{\frac{\pi}{2}+\alpha} 3V_m^2 \sin^2 \left(\omega t + \frac{\pi}{6} \right) \cdot d(\omega t) \right]^{\frac{1}{2}}$$

$$V_{O(rms)} = \sqrt{3}V_m \left(\frac{1}{2} + \frac{3\sqrt{3}}{4\pi} \cos 2\alpha \right)^{\frac{1}{2}}$$

THREE PHASE DUAL CONVERTERS

In many variable speed drives, the four quadrant operation is generally required and three phase dual converters are extensively used in applications up to the 2000 kW level. Figure shows three phase dual converters where two three phase full converters are connected back to back across a common load. We have seen that due to the instantaneous voltage differences between the output voltages of converters, a circulating current flows through the converters. The circulating current is normally limited by circulating reactor, L_r . The two converters are controlled in such a way that if α_1 is the delay angle of converter 1, the delay angle of converter 2 is $\alpha_2 = (\pi - \alpha_1)$.

The operation of a three phase dual converter is similar that of a single phase dual converter system. The main difference being that a three phase dual converter gives much higher dc output voltage and higher dc output power than a single phase dual converter system. But the drawback is that the three phase dual converter is more expensive and the design of control circuit is more complex.

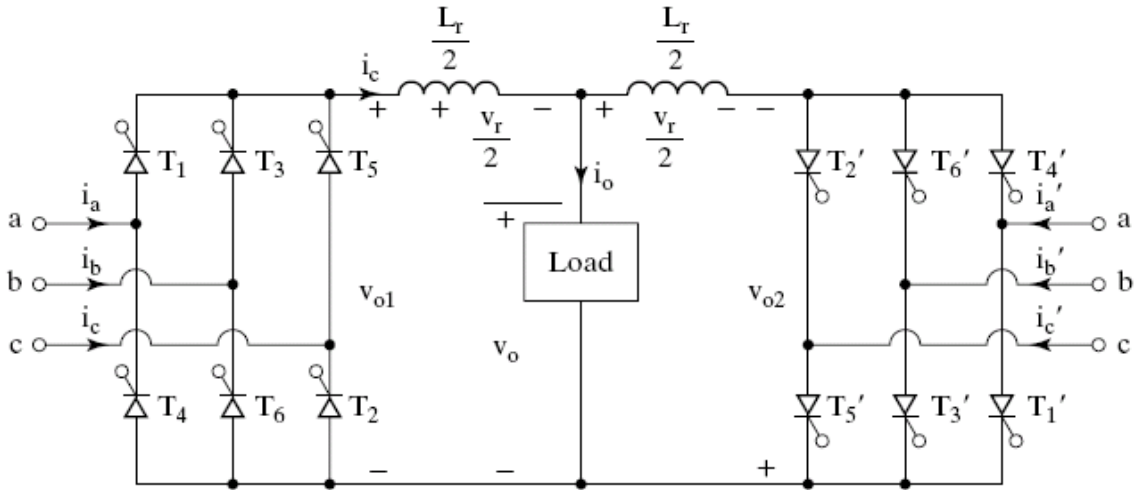

The figure below shows the waveforms for the input supply voltages, output voltages of converter1 and conveter2 , and the voltage across current limiting reactor (inductor) L_r . The operation of each converter is identical to that of a three phase full converter.

During the interval $\left(\frac{\pi}{6} + \alpha_1\right)$ to $\left(\frac{\pi}{2} + \alpha_1\right)$, the line to line voltage v_{ab} appears across the output of converter 1 and v_{bc} appears across the output of converter 2

We define three line neutral voltages (3 phase voltages) as follows

$$v_{RN} = v_{an} = V_m \sin \omega t \quad ; \quad V_m = \text{Max. Phase Voltage}$$

$$v_{YN} = v_{bn} = V_m \sin \left(\omega t - \frac{2\pi}{3} \right) = V_m \sin (\omega t - 120^\circ)$$

$$v_{BN} = v_{cn} = V_m \sin \left(\omega t + \frac{2\pi}{3} \right) = V_m \sin (\omega t + 120^\circ) = V_m \sin (\omega t - 240^\circ)$$

The corresponding line-to-line supply voltages are

$$v_{RY} = v_{ab} = (v_{an} - v_{bn}) = \sqrt{3}V_m \sin\left(\omega t + \frac{\pi}{6}\right)$$

$$v_{YB} = v_{bc} = (v_{bn} - v_{cn}) = \sqrt{3}V_m \sin\left(\omega t - \frac{\pi}{2}\right)$$

$$v_{BR} = v_{ca} = (v_{cn} - v_{an}) = \sqrt{3}V_m \sin\left(\omega t + \frac{\pi}{2}\right)$$

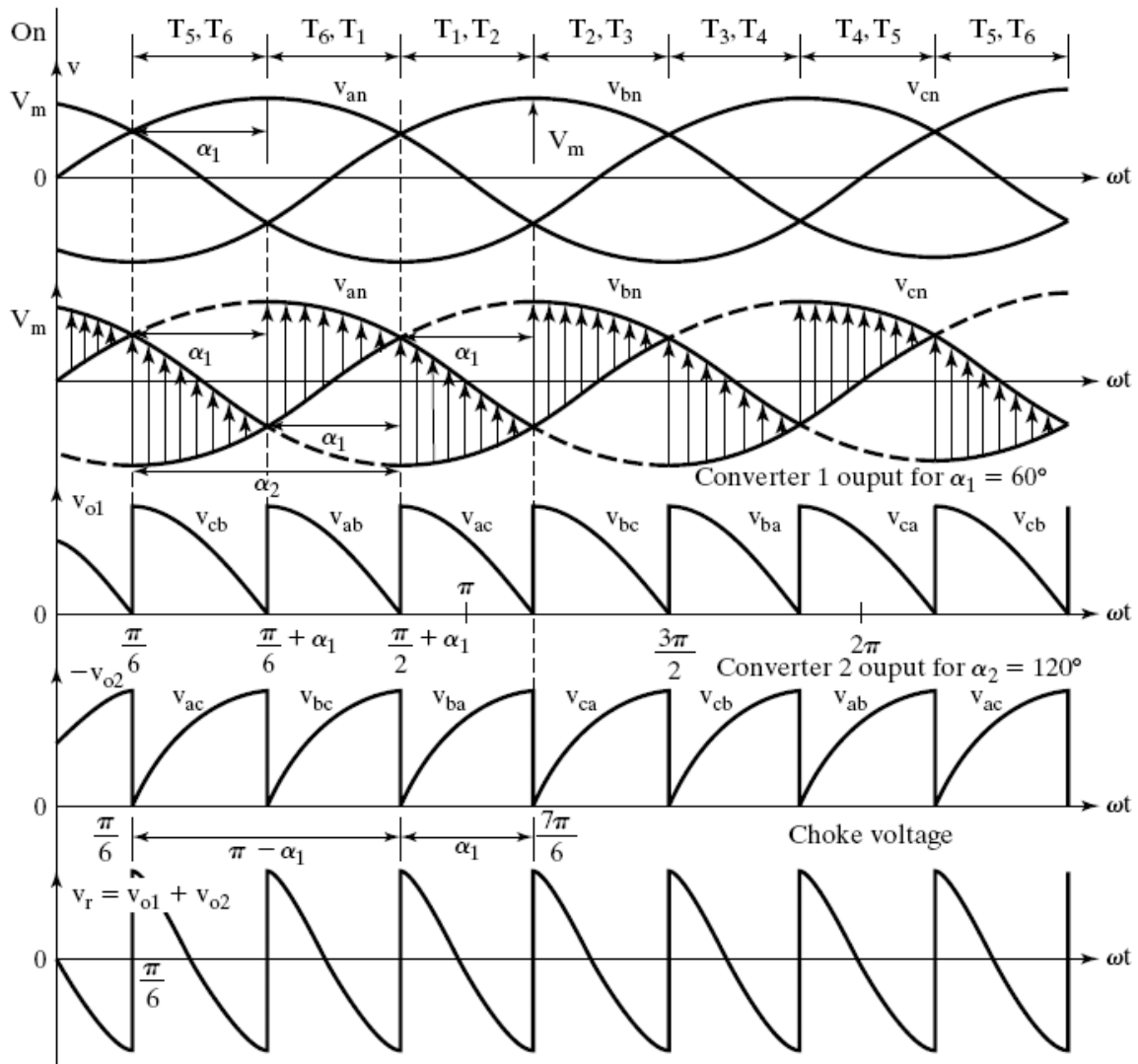

TO OBTAIN AN EXPRESSION FOR THE CIRCULATING CURRENT

If v_{o1} and v_{o2} are the output voltages of converters 1 and 2 respectively, the instantaneous voltage across the current limiting inductor during the interval

$\left(\frac{\pi}{6} + \alpha_1\right) \leq \omega t \leq \left(\frac{\pi}{2} + \alpha_1\right)$ is

$$v_r = (v_{o1} + v_{o2}) = (v_{ab} - v_{bc})$$

$$v_r = \sqrt{3}V_m \left[\sin\left(\omega t + \frac{\pi}{6}\right) - \sin\left(\omega t - \frac{\pi}{2}\right) \right]$$

$$v_r = 3V_m \cos\left(\omega t - \frac{\pi}{6}\right)$$

The circulating current can be calculated by using the equation

$$i_r(t) = \frac{1}{\omega L_r} \int_{\frac{\pi}{6} + \alpha_1}^{\omega t} v_r \cdot d(\omega t)$$

$$i_r(t) = \frac{1}{\omega L_r} \int_{\frac{\pi}{6} + \alpha_1}^{\omega t} 3V_m \cos\left(\omega t - \frac{\pi}{6}\right) \cdot d(\omega t)$$

$$i_r(t) = \frac{3V_m}{\omega L_r} \left[\sin\left(\omega t - \frac{\pi}{6}\right) - \sin \alpha_1 \right]$$

$$i_{r(\max)} = \frac{3V_m}{\omega L_r} = \text{maximum value of the circulating current.}$$

There are two different modes of operation of a three phase dual converter system.

- Circulating current free (non circulating) mode of operation
- Circulating current mode of operation

CIRCULATING CURRENT FREE (NON-CIRCULATING) MODE OF OPERATION

In this mode of operation only one converter is switched on at a time when the converter number 1 is switched on and the gate signals are applied to the thyristors the average output voltage and the average load current are controlled by adjusting the trigger angle α_1 and the gating signals of converter 1 thyristors.

The load current flows in the downward direction giving a positive average load current when the converter 1 is switched on. For $\alpha_1 < 90^\circ$ the converter 1 operates in the rectification mode V_{dc} is positive, I_{dc} is positive and hence the average load power P_{dc} is positive.

The converter 1 converts the input ac supply and feeds a dc power to the load. Power flows from the ac supply to the load during the rectification mode. When the trigger angle α_1 is increased above 90° , V_{dc} becomes negative where as I_{dc} is positive because the thyristors of converter 1 conduct in only one direction and reversal of load current through thyristors of converter 1 is not possible.

For $\alpha_1 > 90^\circ$ converter 1 operates in the inversion mode & the load energy is supplied back to the ac supply. The thyristors are switched-off when the load current decreases to zero & after a short delay time of about 10 to 20 milliseconds, the converter 2 can be switched on by releasing the gate control signals to the thyristors of converter 2.

We obtain a reverse or negative load current when the converter 2 is switched ON. The average or dc output voltage and the average load current are controlled by adjusting the trigger angle α_2 of the gate trigger pulses supplied to the thyristors of converter 2. When α_2 is less than 90° , converter 2 operates in the rectification mode and converts the input ac supply in to dc output power which is fed to the load.

When α_2 is less than 90° for converter 2, V_{dc} is negative & I_{dc} is negative, converter 2 operates as a controlled rectifier & power flows from the ac source to the load circuit. When α_2 is increased above 90° , the converter 2 operates in the inversion mode with V_{dc} positive and I_{dc} negative and hence P_{dc} is negative, which means that power flows from the load circuit to the input ac supply. The power flow from the load circuit to the input ac source is possible if the load circuit has a dc source of appropriate polarity. When the load current falls to zero the thyristors of converter 2 turn-off and the converter 2 can be turned off.

CIRCULATING CURRENT MODE OF OPERATION

Both the converters are switched on at the same time in the mode of operation. One converter operates in the rectification mode while the other operates in the inversion mode. Trigger angles α_1 & α_2 are adjusted such that $(\alpha_1 + \alpha_2) = 180^\circ$

When $\alpha_1 < 90^\circ$, converter 1 operates as a controlled rectifier. When α_2 is made greater than 90° , converter 2 operates in the inversion mode. V_{dc} , I_{dc} , P_{dc} are positive.

When $\alpha_2 < 90^\circ$, converter 2 operates as a controlled rectifier. When α_1 is made greater than 90° , converter 1 operates as an Inverter. V_{dc} and I_{dc} are negative while P_{dc} is positive.

MODULE - III&IV

DC-DC BUCK CONVERTER

A chopper is a static device that converts fixed DC input voltage to variable output voltage directly. Chopper are mostly used in electric vehicle, mini haulers.

Chopper are used for speed control and braking. The systems employing chopper offer smooth control, high efficiency and have fast response.

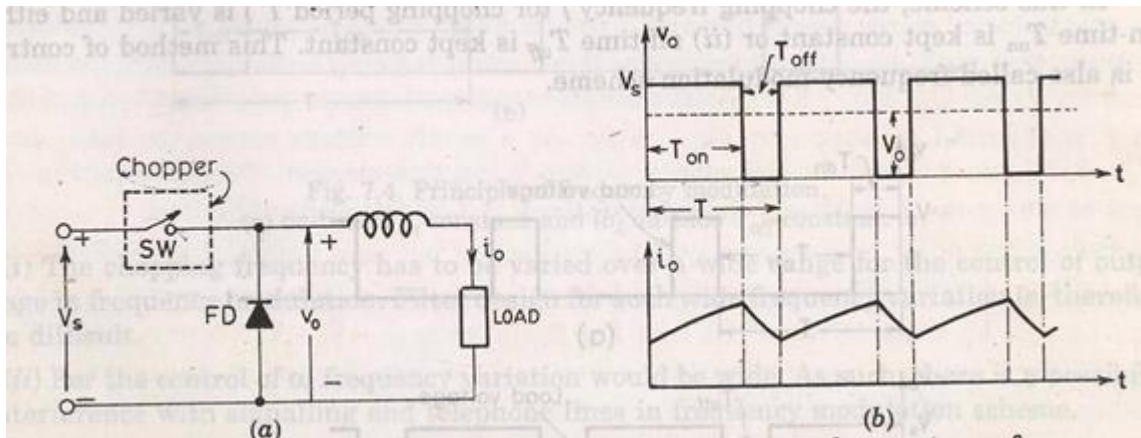

The average output voltage is

$$V_a = \frac{1}{T} \int_0^{t_1} V_0 dt = \frac{1}{T} V_s (t_1) = f t_1 V_s = \alpha V_s$$

The average load current

$$I_a = \frac{V_a}{R} = \frac{\alpha V_s}{R}$$

Where, T=chopping period

Duty cycle of chopper =

$$\alpha = \frac{t_1}{T}$$

f=chopping frequency

The rms value of output voltage is

$$V_0 = \left(\frac{1}{T} \int_0^{\alpha} V_0^2 dt \right)^{\frac{1}{2}} = \sqrt{\alpha} V_s$$

If we consider the converter to be loss less then the input power is equal to the output power and is given by

$$P_i = \frac{1}{T} \int_0^{\alpha T} V_0 i dt = \frac{1}{T} \int_0^{\alpha T} \frac{V_o^2}{R} dt$$

$$= \frac{1}{T} \frac{V_s^2}{R} (\alpha T) = \frac{\alpha V_s^2}{R}$$

The effective input resistance seen by the P source is

$$P_i = \frac{V_s}{I_a} = \frac{V_s}{\frac{\alpha V_s}{R}} = \frac{R}{\alpha}$$

The duty cycle α can be varied by varying t_1 , T of frequency.

Constant frequency operation:

1) The chopping period T is kept constant and on time is varied.

The pulse width modulation, the width of the pulse is varied.

2) Variable frequency operation, the chopping frequency f is varied.

Frequency modulation, either on time or off time is kept constant.

This type of control generate harmonics at unpredictable frequency and filter design is often difficult.

TYPES OF CHOPPER:

FIRST QUADRANT OR TYPE A CHOPPER:

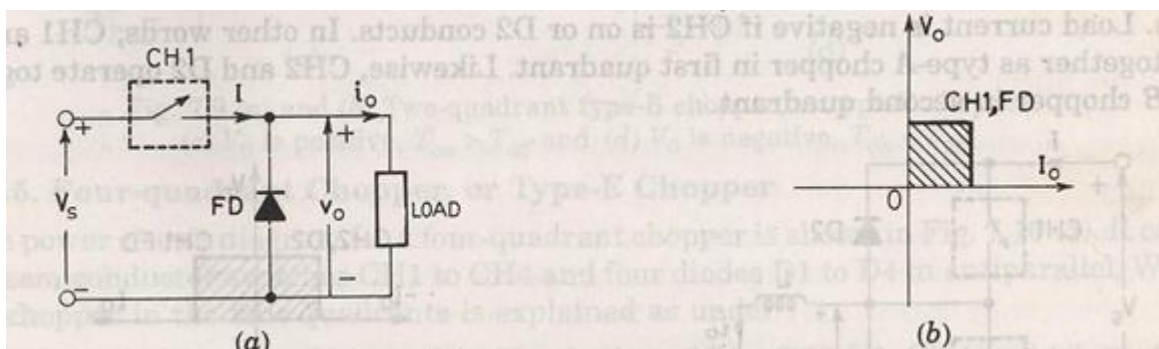

When switch ON

$$V_0 = V_s$$

Current i_o flows in the same direction when switch off.

$$V_o=0, i_o=0$$

So, average value of both the load and the current are positive.

SECOND QUADRANT OR TYPE B CHOPPER:

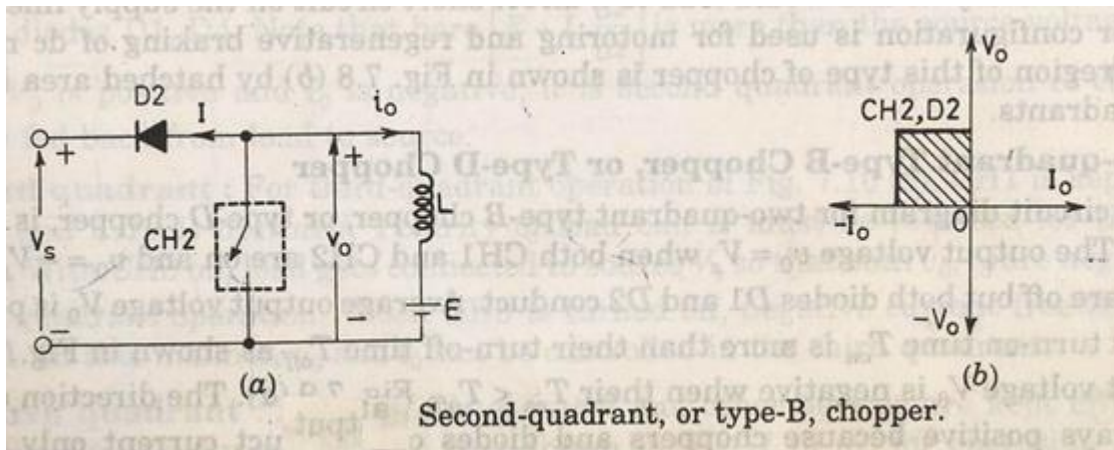

When switch are closed the load voltage E drives current through L and switch. During T_{on}

L stores energy.

When switch off V_o exceeds source voltage V_s .

$$V_o = E + L \frac{di}{dt}$$

Diode D_2 is forward biased. power is fed back to supply. As V_o is more than source voltage. So such chopper is called step up chopper.

$$V_o = E + L \frac{di}{dt}$$

So current is always negative and V_o is always positive.

TWO QUADRANT TYPE A CHOPPER OR, TYPE C CHOPPER:

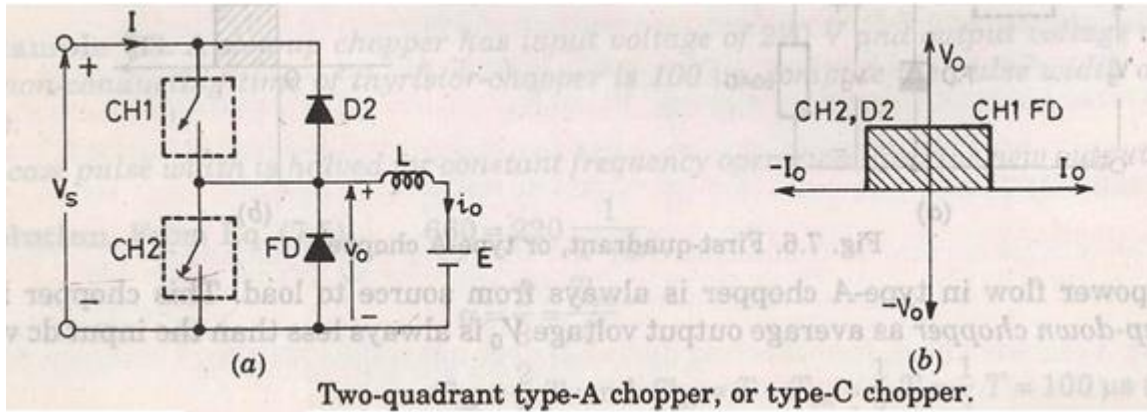

Both the switches never switch ON simultaneously as it lead direct short circuit of the supply.

Now when sw2 is closed or FD is on the output voltage V_o is zero.

When sw1 is ON or diode D conducts output voltage is V_o is $+V_s'$

CURRENT ANALYSIS:

When CH1 is ON current flows along i_o . When CH1 is off current continues to flow along i_o as FD is forward biased. So i_o is positive.

Now when CH2 is ON current direction will be opposite to i_o . When sw2 is off D2 turns ON.

Load current is $-i_o$. So average load voltage is always positive. Average load current may be positive or negative.

TWO QUADRANT TYPE B CHOPPER, OR TYPE D CHOPPER:

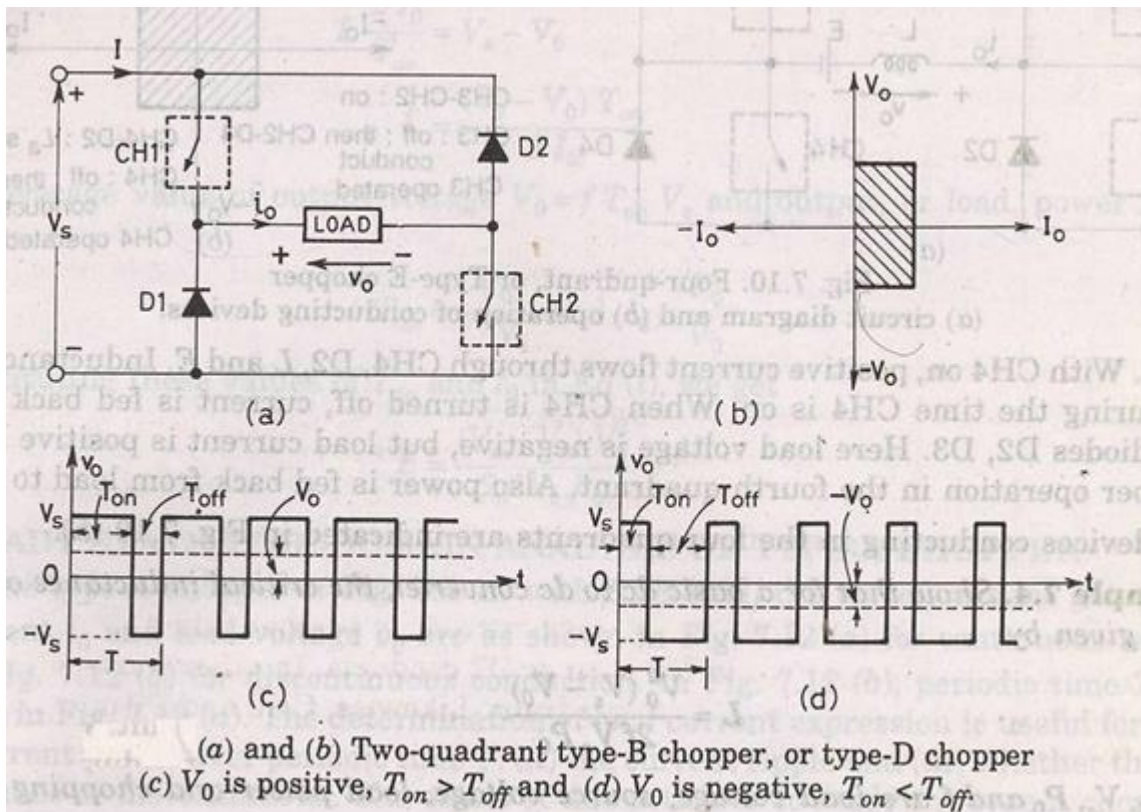

When CH1 and CH2 both are on then $V_0 = V_s$.

When CH1 and CH2 are off and D1 and D2 are on $V_0 = -V_s$.

The direction of current is always positive because chopper and diode can only conduct in the direction of arrow shown in fig.

Average voltage is positive when $T_{on} > T_{off}$

FOUR QUADRANT CHOPPER, OR TYPE E CHOPPER

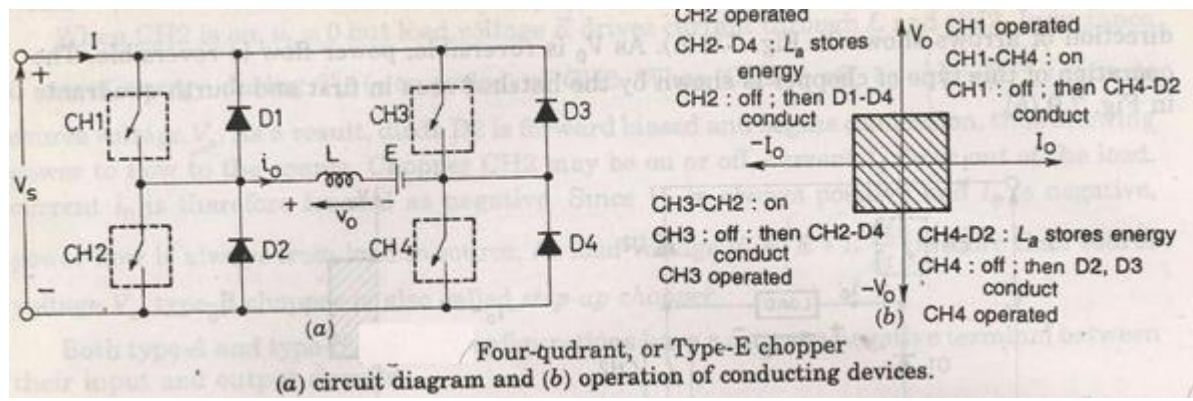

FIRST QUADRANT:

CH4 is kept ON

CH3 is off

CH1 is operated

$$V_0 = V_s$$

$i_0 =$ positive

when CH1 is off positive current free wheels through CH4, D2

so V_0 and I_2 is in first quadrant.

SECOND QUADRANT:

CH1, CH3, CH4 are off.

CH2 is operated.

Reverse current flows and I is negative through L CH2 D4 and E.

When CH2 off D1 and D4 is ON and current i_d fed back to source. So

$$E + L \frac{di}{dt} \text{ is more than source voltage } V_s.$$

As i_0 is negative and V_0 is positive, so second quadrant operation.

THIRD QUADRANT:

CH1 OFF, CH2 ON

CH3 operated. So both V_0 and i_0 is negative.

When CH3 turned off negative current freewheels through CH2 and D4.

FOURTH QUADRANT:

CH4 is operated other are off.

Positive current flows through CH4 E L D2.

Inductance L stores energy when current fed to source through D3 and D2. V_0 is negative.

STEADY STATE ANALYSIS OF PRACTICAL BUCK CHOPPER:

The voltage across the inductor L is $e_L = L di/dt$.

$$V_s - V_a = L \frac{d(i_2 - i_1)}{dt} = L \frac{\Delta i}{t_1}$$

$$t_1 = \frac{\Delta i L}{V_s - V_a}$$

The inductor current falls linearly from I_2 to I_1 in time t_2 as $V_s = 0$.

So

$$-V_a = \frac{L(i_1 - i_2)}{t_2}$$

If $I_2 - I_1 = \Delta I$ then

$$-V_a = -\frac{L\Delta I}{t_2}$$

$$t_2 = \frac{L\Delta I}{V_a}$$

$\Delta I = I_2 - I_1 =$ peak to peak ripple current.

$$\Delta I = \frac{(V_s - V_a)t_1}{L} = \frac{V_a t_2}{L}$$

Now $t_1 = \alpha T$, $t_2 = (1 - \alpha)T$

$$V_a = V_s \frac{t_1}{T} = \alpha V_s$$

$\alpha < 1$ so it is a step down or buck converter.

If the circuit is lossless then $V_s I_s = V_a I_a = \alpha V_s I_a$

$$I_s = \alpha I_a$$

Now switching period T can be expressed as

$$T=1/f= t_1+ t_2=\Delta I L/(V_s-V_a) + \Delta I L/(V_a)$$

$$=\Delta I L V_s/V_a(V_s-V_a)$$

So peak to peak ripple current

$$\Delta I = \frac{V_a(V_s - V_a)}{fL V_s}$$

$$\Delta I = \frac{V_a \alpha(1-\alpha)}{fL}$$

The peak to peak voltage of the capacitor is

$$\Delta V_c = \frac{\Delta I}{8fc}$$

So from above equation

$$\Delta V_c = \frac{V_a(V_s - V_a)}{8Lcf^2 V_s} \cdot \frac{V_s \alpha(1-\alpha)}{8Lcf^2}$$

Condition for continuous inductor current and capacitor voltage :

If I_L is the average inductor current

$$\Delta I_L = 2I_L \dots \text{as}$$

$$V_a = \alpha V_s$$

$$\frac{V_s \alpha(1-\alpha)}{fL} =$$

$$\text{As } \frac{I_2 - I_1}{2} = I_L$$

$$\text{So } \Delta I = 2I_L$$

$$\frac{V_s \alpha(1-\alpha)}{fL} \dots \text{eq (2)}$$

$$\frac{V_s \alpha(1-\alpha)}{fL} = 2I_L = 2I_a = \frac{2\alpha V_s}{R} \dots \text{eq(4)}$$

$$\text{As } V_a = \alpha V_s \text{ so } I_a = \frac{\alpha V_s}{R}$$

$$2I_a = \frac{2\alpha V_s}{R}$$

So equation 4 gives

$$L_c = \frac{(1-\alpha)R}{2f}$$

Which is the critical value of inductor

$$\Delta V_c = 2V_a$$

$$2V_a = \frac{V_s \alpha (1-\alpha)}{8L_c f^2} = 2\alpha V_s$$

$$c = \frac{1-\alpha}{16L_c f^2}$$

Peak to peak ripple voltage of capacitor:

$$\Delta V_c = V_c - V_c(t=0)$$

$$= \frac{1}{c} \int_0^{t_1} I_c dt = \frac{1}{c} \int_0^{t_1} I_a dt = \frac{I_a t_1}{c}$$

$$\text{So } t_1 = \frac{V_a - V_s}{V_{af}}$$

$$t_1 = \frac{V_a - V_s}{V_{af}}$$

$$\Rightarrow 1 - \alpha = \frac{V_s}{V_a}$$

$$\Rightarrow 1 - \frac{t_1}{T} = \frac{V_s}{V_a}$$

$$\Rightarrow t_1 = \frac{V_a - V_s}{V_a f}$$

$$\text{So } \Delta V_c = \frac{I_a}{c} \left(\frac{V_a - V_s}{V_{af}} \right)$$

$$\Rightarrow \Delta V_c = \frac{I_a \alpha}{fc}$$

Condition for continuous inductor current and capacitor voltage:

If I_L = average inductor current then

$$I_L = \frac{\Delta I}{2}$$

$$\Delta I = \frac{V_s \alpha}{fL} = 2I_L = 2I_a = \frac{2V_s}{(1-\alpha)R}$$

As $V_a = \frac{V_s}{1-\alpha}$

$$\Rightarrow 2I_a = \frac{2V_s}{(1-\alpha)R}$$

So $\Delta I_L = 2I_L = 2I_a = \frac{2V_s}{(1-\alpha)R} = \frac{V_s \alpha}{fL}$

$$\Rightarrow L_c = \frac{\alpha(1-\alpha)R}{2f}$$

$$\Delta V_c = 2V_a$$

$$\frac{I_a \alpha}{cf} = 2V_a = 2I_a R$$

$$c = \frac{\alpha}{2fR}$$

Step Up Chopper or Boost Converter

The average voltage output (V_o) in a step up chopper is greater than the voltage input (V_s). The figure below shows a configuration of a step up chopper.

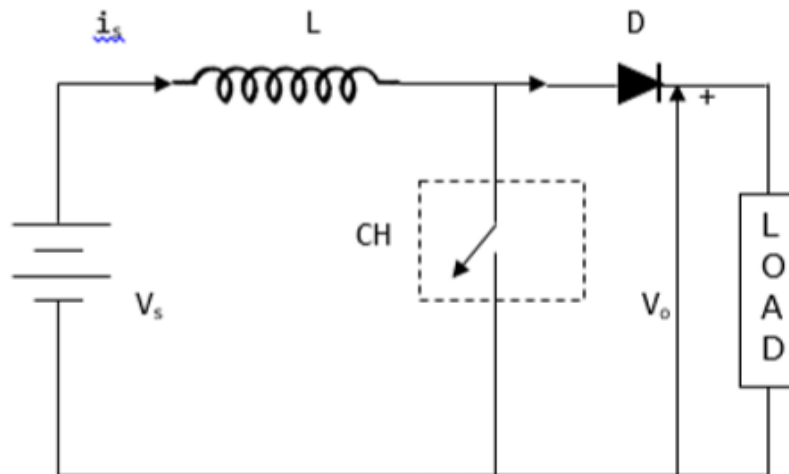

Current and Voltage Waveforms

V_o average voltage output is positive when chopper is switched ON and negative when the chopper is OFF as shown in the waveform below.

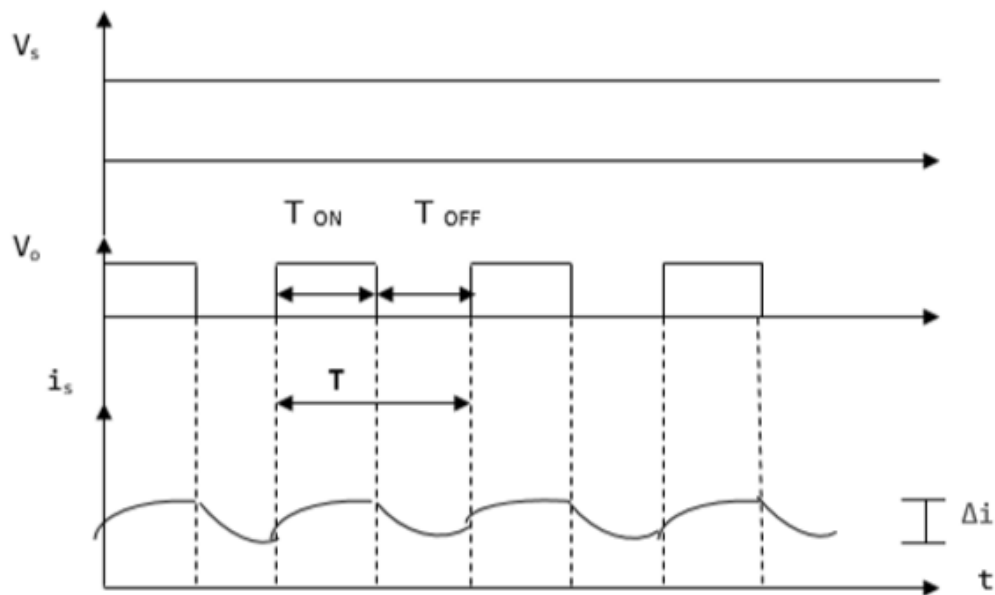

Where

T_{ON} – time interval when chopper is ON

T_{OFF} – time interval when chopper is OFF

V_L – Load voltage

V_s – Source voltage

T – Chopping time period = $T_{ON} + T_{OFF}$

V_0 is given by –

$$V_0 = \frac{1}{T} \int_0^{T_{ON}} V_S dt$$

When the chopper CH is switched ON, the load is short circuited and, therefore, the voltage output for the period T_{ON} is zero. In addition, the inductor is charged during this time. This gives $V_S = V_L$

$$L \frac{di}{dt} = V_S, \quad \frac{\Delta i}{T_{ON}} = \frac{V_S}{L}$$

Hence, $\Delta i = \frac{V_S}{L} T_{ON}$

Δi is the inductor peak to peak current. When the chopper CH is OFF, discharge occurs through the inductor L . Therefore, the summation of the V_s and V_L is given as follows –

$$V_0 = V_S + V_L, \quad V_L = V_0 - V_S$$

But $L \frac{di}{dt} = V_0 - V_S$

Thus, $L \frac{\Delta i}{T_{OFF}} = V_0 - V_S$

This gives, $\Delta i = \frac{V_0 - V_S}{L} T_{OFF}$

Equating Δi from ON state to Δi from OFF state gives -

$$\frac{V_S}{L} T_{ON} = \frac{V_0 - V_S}{L} T_{OFF} \quad , \quad V_S (T_{ON} + T_{OFF}) = V_0 T_{OFF}$$

$$V_0 = \frac{TV_S}{T_{OFF}} = \frac{V_S}{\frac{(T+T_{ON})}{T}}$$

This give the average voltage output as,

$$V_0 = \frac{V_S}{1 - D}$$

The above equation shows that V_0 can be varied from V_S to infinity. It proves that the output voltage will always be more than the voltage input and hence, it boosts up or increases the voltage level.

MODULE – V

INVERTERS

The device that converts dc power into ac power at desired output voltage and frequency is called an inverter.

Single phase voltage source inverters

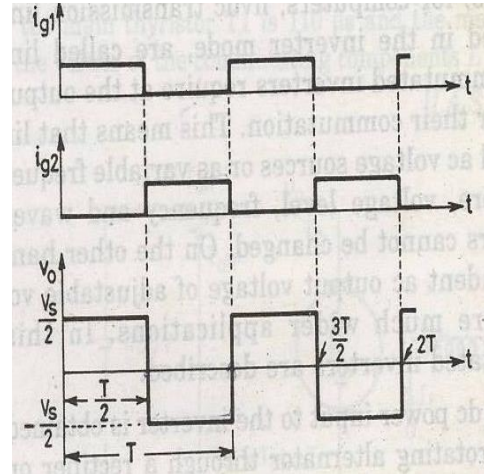
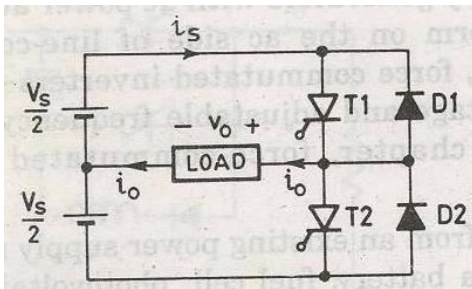

$$V_o(\text{rms}) = \frac{1}{T_0/2} \int_0^{T_0/2} \frac{V_s^2}{4} dt = \frac{V_s}{2}$$

$$V_o = \frac{a_0}{2} + \sum_{n=1}^{\infty} (a_n \cos(n\omega t) + b_n \sin(n\omega t))$$

Due to symmetry along x-axis

$$a_0 = 0, a_n = 0$$

$$b_n = \frac{4V_s}{n\pi}$$

The instantaneous output voltage

$$v_o = \sum_{n=1,3,5,\dots}^{\infty} \frac{2V_s}{n\pi} \sin(n\omega t)$$

$$=0, \quad n=2,4,\dots$$

The rms value of the fundamental output voltage

$$V_{o1} = \frac{2V_s}{\sqrt{2}\pi} = 0.45V_s$$

$$\begin{aligned} \text{So if } V_0 &= \sum_{n=1,3,5,\dots}^{\infty} \frac{2V_S}{n\pi} \sin(n\omega t) \\ &= \sum_{n=1,3,5,\dots}^{\infty} \frac{2V_S}{n\pi\sqrt{R^2+(n\omega L)^2}} \sin(n\omega t - \theta_n) \end{aligned}$$

$$P_{01} = (I_{01})^2 R = \left[\frac{2V_S}{\sqrt{2}\pi\sqrt{R^2+(n\omega L)^2}} \right]^2 R$$

DC Supply Current

Assuming a lossless inverter, the ac power absorbed by the load must be equal to the average power supplied by the dc source.

$$\int_0^T i_s(t) dt = \frac{1}{V_s} \int_0^T \sqrt{2}V_{01} \sin(\omega t) \sqrt{2}I_0 \sin(\omega t - \theta_1) dt = I_s$$

V_{01} = Fundamental rms output voltage

I_0 = rms load current

θ_1 = the load angle at the fundamental frequency

Single phase full bridge inverter

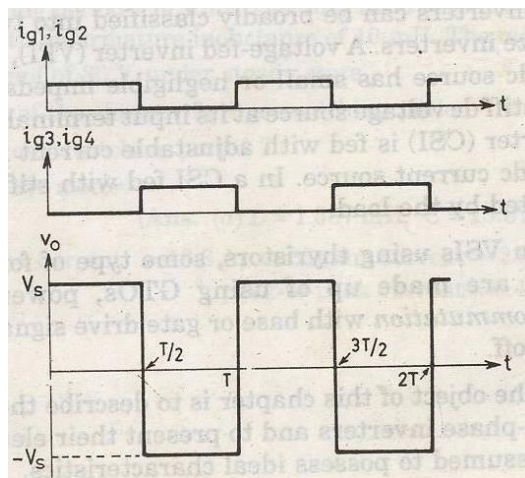
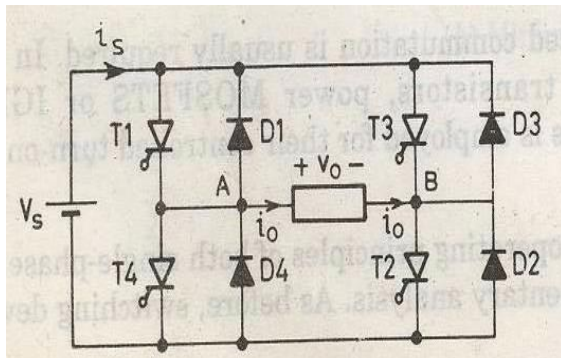

For $n=1$, $V_1 = \frac{4V_S}{\sqrt{2}\pi} = 0.9V_S$ (The rms of fundamental)

Instantaneous load current i_0 for an RL load

$$i_0 = \sum_{n=1,3,5,\dots}^{\infty} \frac{4V_S}{n\pi\sqrt{R^2+(n\omega L)^2}} \sin(n\omega t - \theta_n)$$

$$\theta_n = \tan^{-1}\left(\frac{n\omega L}{R}\right)$$

The rms output voltage is

$$V_0 = \left(\frac{2}{T_0} \int_0^{T/2} V_S^2 dt \right)^{1/2} = V_S$$

The instantaneous output voltage in a fourier series

$$v_o = \sum_{n=1,3,5,\dots}^{\infty} \frac{4V_s}{n\pi} \sin(n\omega t)$$

Single phase bridge inverter

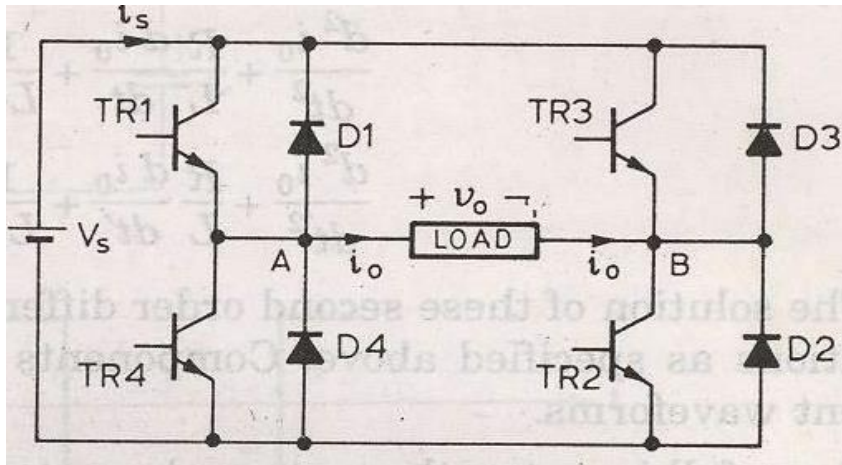

INVERTER

Inverters are of the two types

- 1) VSI
- 2) CSI

Pulse width model

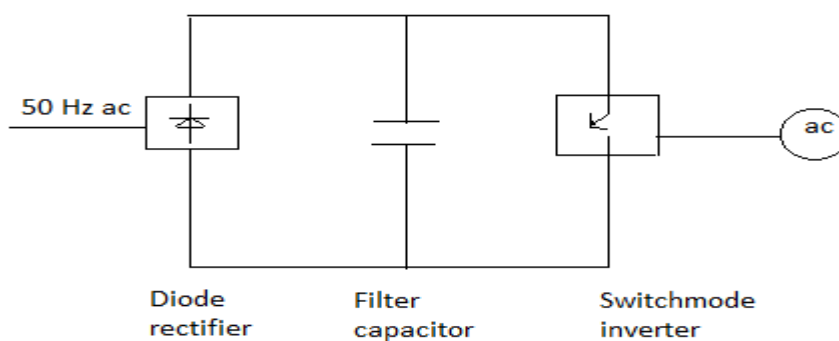

The VSI can be further divided into general 3 categories:

1. Pulse width modulated inverters
2. Square wave inverters
3. Single phase inverter with voltage cancellation

Pulse width modulated inverters

The input dc voltage is of constant magnitude . The diode rectifier is used to rectify the line voltage. The inverter control the magnitude and frequency of the ac output voltage.

This is achieved by PWM technique of inverter switches and this is called PWM inverters.

The sinusoidal PWM technique is one of the PWM technique to shape the output voltage to as close as sinusoidal output.

Basic concepts of switch mode inverter

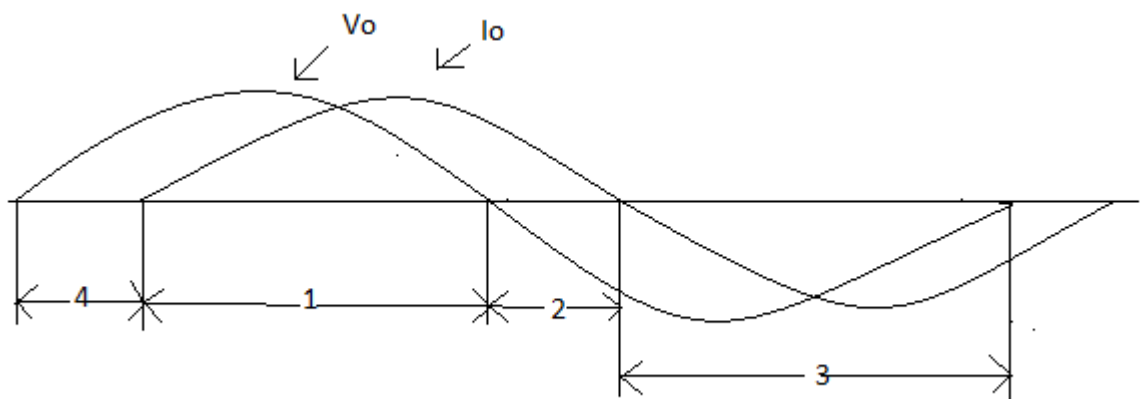
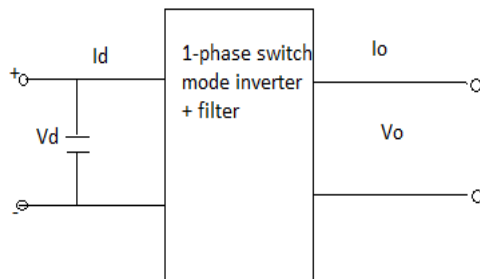

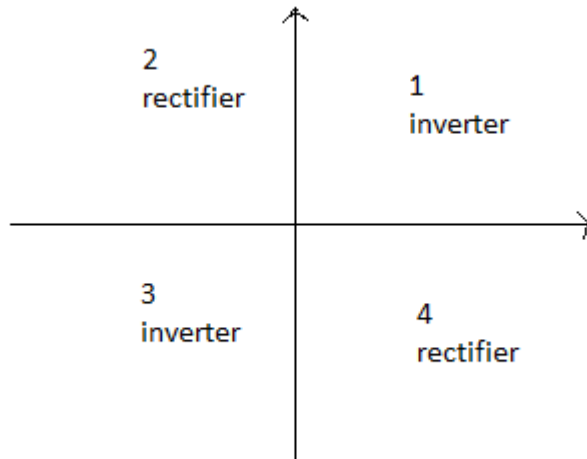

During interval 1 v_0 and i_0 both are positive

During interval 3 v_0 and i_0 both are negative

Therefore during 1 and 3 the instantaneous power flow is from dc side to corresponding to inverter mode of operation.

In contrast during interval 2 and 4 v_0 and i_0 are of opposite sign i.e. power flows from ac side to dc side corresponding to rectifier mode of operation.

Pulse width modulated switching scheme

We require the inverter output to be sinusoidal with magnitude and frequency controllable.

In order to produce sinusoidal output voltage at desired frequency a sinusoidal control signal at desired frequency is compared with a triangular waveform as show.

The frequency of the triangular waveform established the inverter switching frequency.

The triangular waveform is called carrier waveform. The triangular waveform establishes switching frequency f_s , which establishes with which the inverter switches are applied.

The control signal has frequency f_s and is used to modulate the switch duty ratio.

f_1 is the desired fundamental frequency of the output voltage.

The amplitude modulation ratio m_a is defined as

$$m_a = \frac{V_{control}}{V_{tri}}$$

$V_{control}$ is the peak amplitude of control signal.

V_{tri} peak amplitude of triangular signal.

The frequency modulation ratio m_f

$$m_f = \frac{f_s}{f_1}$$

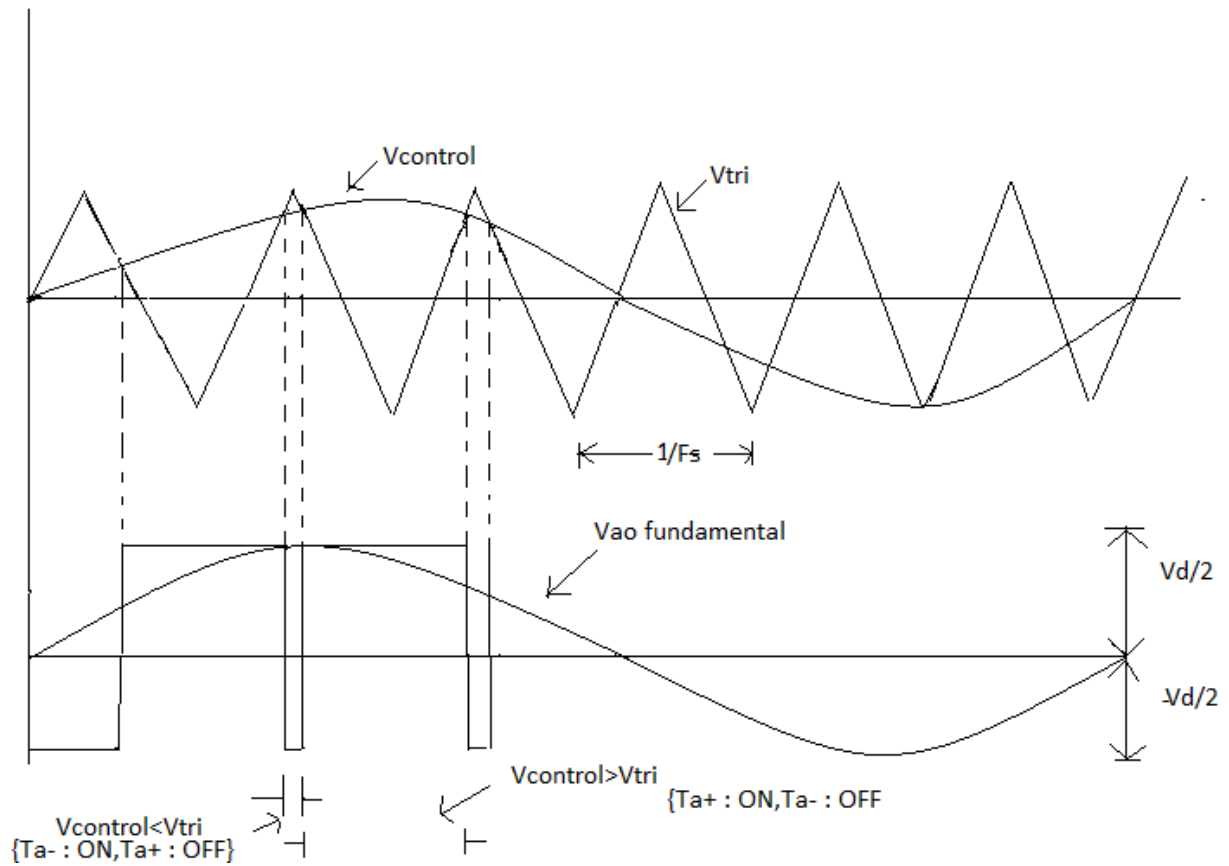

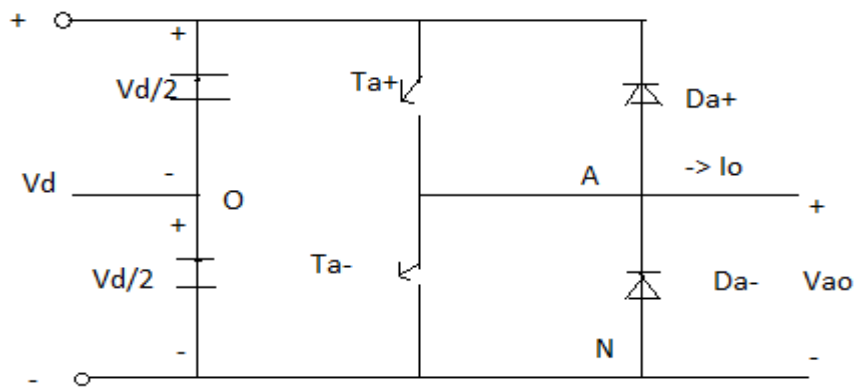

When $V_{control} > V_{tri}$ T_A^+ is ON $V_{AO} = \frac{1}{2}V_d$

$V_{control} < V_{tri}$ T_A^- is ON $V_{AO} = -\frac{1}{2}V_d$

So the following inferences can be drawn

The peak amplitude of fundamental frequency is m_a times $\frac{1}{2}V_d$

$$V_{AO} = m_a \frac{V_d}{2}$$

$$V_{AO} = \frac{V_{control}}{\hat{V}_{tri}} * \frac{V_d}{2} \quad V_{control} \leq \hat{V}_{tri}$$

The foregoing arguments shown why $V_{control}$ is chosen to be sinusoidal to provide sinusoidal output voltage with fewer harmonics

Let the $V_{control}$ vary sinusoidal with frequency f_1 , which is the desired frequency of the inverter output voltage.

$$\text{Let } V_{control} = \hat{V}_{control} \sin \omega_1 t$$

$$\hat{V}_{control} \leq \hat{V}_{tri}$$

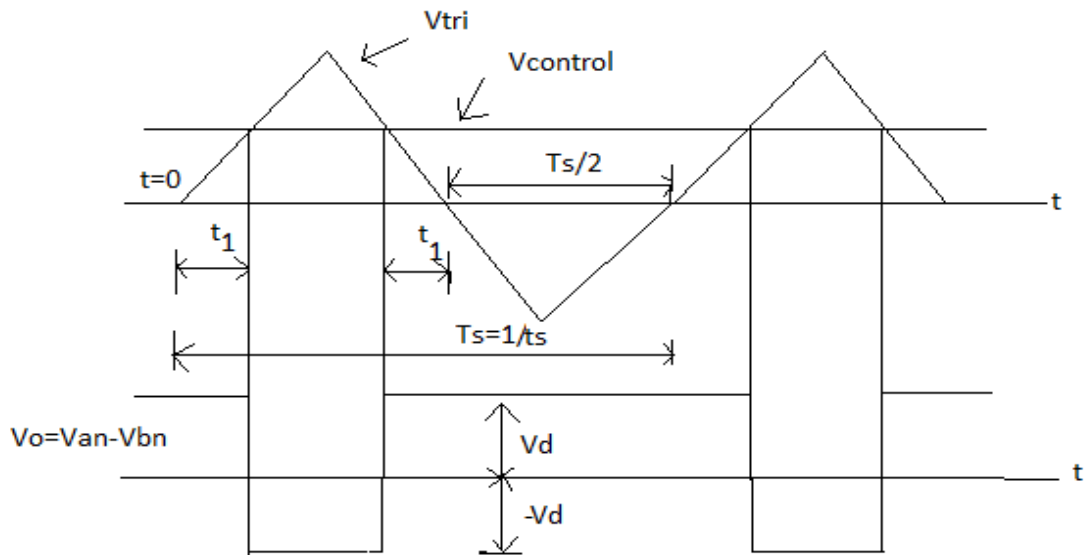

$$\frac{\hat{v}_{tri}}{t_1} = \frac{\hat{V}_{tri}}{T_s/4}$$

At $t=t_1$, $v_{tri}=v_{control}$

$$\text{So } \frac{v_{control}}{t_1} = \frac{\hat{V}_{tri}}{T_s/4}$$

$$t_1 = \frac{\hat{v}_{control} * T_s}{\hat{V}_{tri} * 4}$$

$$T_{on} = 2t_1 + \frac{T_s}{2}$$

$$D_1 = \frac{T_{on}}{T_s} = \frac{2t_1 + \frac{T_s}{2}}{T_s}$$

$$= \frac{1}{2} + \frac{2t_1}{T_s}$$

$$D_1 = \frac{1}{2} + \frac{1}{2} \left(\frac{\hat{v}_{control}}{\hat{V}_{tri}} \right)$$

Three phase inverter

When three single-phase inverters are connected in parallel a three phase inverter is formed.

The gating signal has to be displaced by 120° with respect to each other so as achieve three phase balanced voltages.

A 3-phase output can be achieved from a configuration of six transistors and six diodes.

Two type of control signal can be applied to transistors, they are such as 180° or 120° conduction.

180-degree conduction

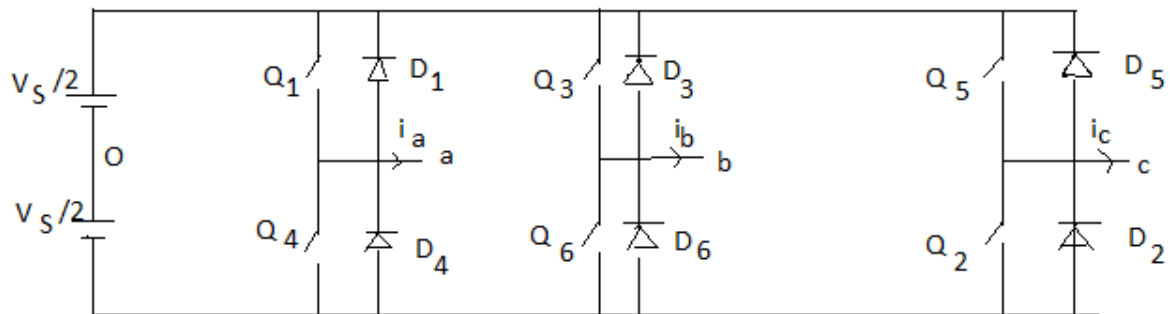

When Q_1 is switched on, terminal a is connected to the positive terminal of dc input voltage.

When Q_4 is switched on terminal a is brought to negative terminal of the dc source.

There are 6 modes of operation in a cycle and the duration of each mode is 60° .

The conduction sequence of transistors is 123,234,345,456,561,612. The gating signals are shifted from each other by 60° to get 3- ϕ balanced voltages.

Switching states for the three phase voltage inverters

Step I

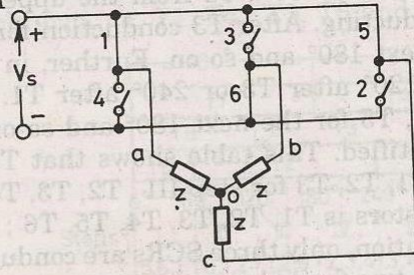

(a) $0-60^\circ$; 5, 6, 1 closed.

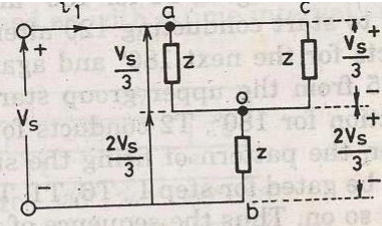

$$v_{ao} = v_{co} = V_s/3$$

$$v_{bo} = -v_{ob} = -2V_s/3$$

Step II

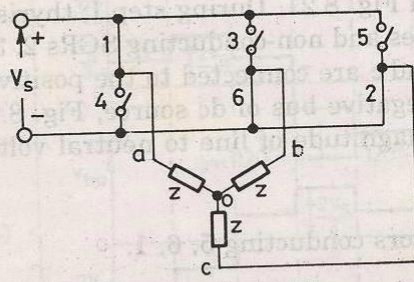

(b) $60-120^\circ$; 6, 1, 2 closed.

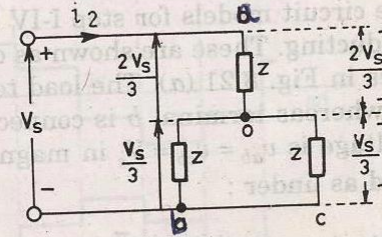

$$v_{ao} = V_s/3$$

$$v_{bo} = v_{co} = -V_s/3$$

Step III

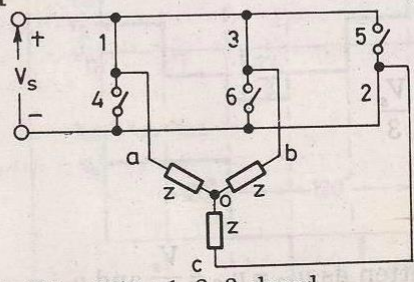

(c) $120-180^\circ$; 1, 2, 3 closed.

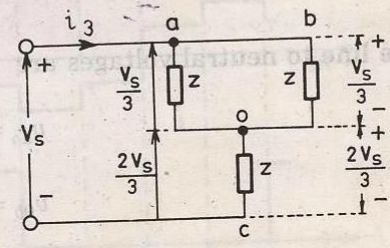

$$v_{ao} = v_{bo} = V_s/3$$

$$v_{co} = -2V_s/3$$

Step IV

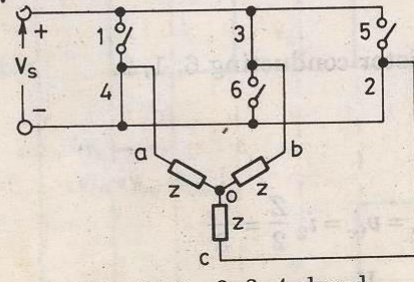

(d) $180-240^\circ$; 2, 3, 4 closed.

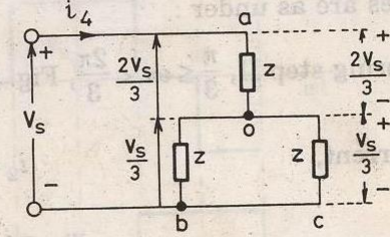

$$v_{bo} = 2V_s/3$$

$$v_{ao} = v_{co} = -V_s/3$$



V_{RN}	V_{YN}	V_{BN}	V_{RY}	V_{YB}	V_{BR}	V_1
$\frac{V}{3}$	$\frac{-2V}{3}$	$\frac{V}{3}$	V_{ac}	$-V_{dc}$	0	$\frac{2}{\sqrt{3}}(330^\circ)$
$\frac{2V}{3}$	$\frac{-V}{3}$	$\frac{-V}{3}$	V_{dc}	0	$-V_{dc}$	$\frac{2}{\sqrt{3}}(30^\circ)$
$\frac{V}{3}$	$\frac{V}{3}$	$\frac{-2V}{3}$	0	V	-V	$\frac{2}{\sqrt{3}}(90^\circ)$
$\frac{-V}{3}$	$\frac{2V}{3}$	$\frac{-V}{3}$	-V	V	0	$\frac{2}{\sqrt{3}}(150^\circ)$
$\frac{-2V}{3}$	$\frac{V}{3}$	$\frac{V}{3}$	-V	0	0	$\frac{2}{\sqrt{3}}(210^\circ)$
$\frac{-V}{3}$	$\frac{-V}{3}$	$\frac{2V}{3}$	0	-V	0	$\frac{2}{\sqrt{3}}(270^\circ)$

Fourier analysis

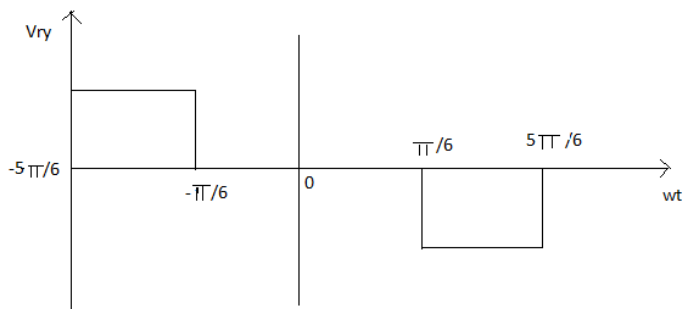

If we go for harmonic analysis $V_{RY} = \sum_{n=1,3,5,\dots}^{\infty} \frac{4V}{n\pi} \sin \frac{n\pi}{3} \sin n(\omega t + \pi/6)$

$$V_{YB} = \sum_{n=1,3,5,\dots}^{\infty} \frac{4V_S}{n\pi} \sin \frac{n\pi}{3} \sin n(\omega t - \pi/2)$$

$$V_{BR} = \sum_{n=1,3,5,\dots}^{\infty} \frac{4V_S}{n\pi} \sin \frac{n\pi}{3} \sin n(\omega t - \pi/6)$$

All even harmonics are zero all triple n harmonics are zero.

The rms nth component of the line voltage is

$$= \frac{4V}{\sqrt{2}n\pi} \sin \frac{n\pi}{3} = \frac{4V}{\sqrt{2}\pi} \sin(60)$$

For n=1

$$= 0.7797V_S$$

Three phase 120° mode VSI

The circuit diagram is same as that for 180° mode of conduction.

Here each thyristor conducts for 120°. There are 6 steps each of 60° duration, for completing one cycle of ac output voltage.

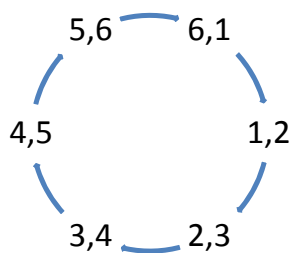

Step I

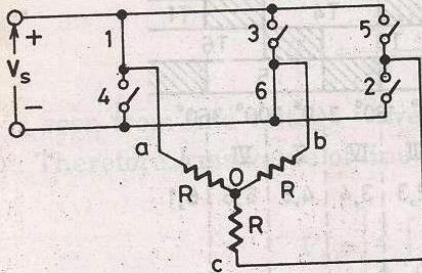

(a) $0-60^\circ$; 6, 1 closed

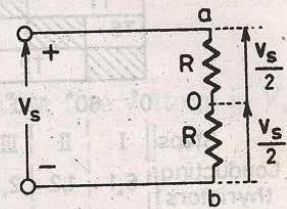

$$v_{ao} = V_s/2$$

$$v_{bo} = -V_s/2 \text{ and } v_{co} = 0$$

Step II

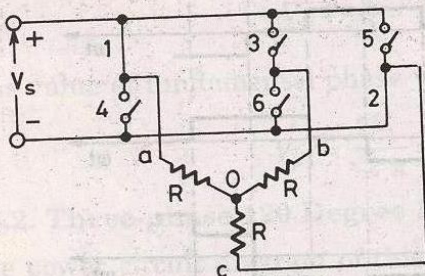

(b) $60-120^\circ$; 1, 2 closed

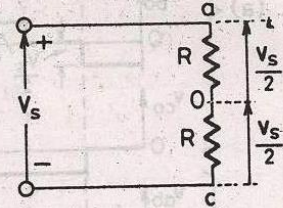

$$v_{ao} = V_s/2$$

$$v_{co} = -V_s/2 \text{ and } v_{bo} = 0$$

Step III

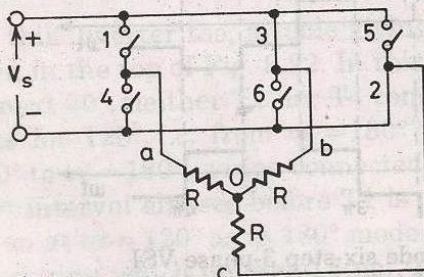

(c) $120-180^\circ$; 2, 3 closed

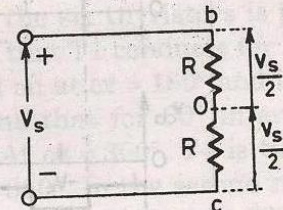

$$v_{bo} = V_s/2$$

$$v_{co} = -V_s/2 \text{ and } v_{ao} = 0$$

Step IV

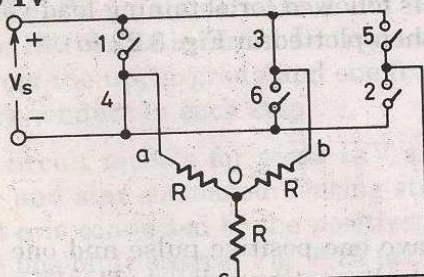

(d) $180-240^\circ$; 3, 4 closed

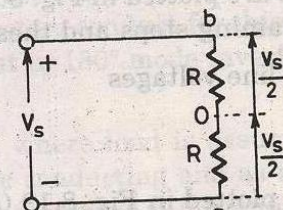

$$v_{bo} = V_s/2$$

$$v_{ao} = -V_s/2 \text{ and } v_{co} = 0$$

Step 1: 6,1 conducting

$$V_{an} = \frac{V_s}{2}, V_{bn} = -\frac{V_s}{2}, V_{cn} = 0$$

Step 2: 1,2 conducting

$$V_{an} = \frac{V_s}{2}, V_{bn} = 0, V_{cn} = -\frac{V_s}{2}$$

Step 3: 2,3 conducting

$$V_{an} = 0, V_{bn} = \frac{V_s}{2}, V_{cn} = -\frac{V_s}{2}$$

Step 4: 3,4 conducting

$$V_{an} = -\frac{V_s}{2}, V_{bn} = \frac{V_s}{2}, V_{cn} = 0$$

Step 5: 4,5 conducting

$$V_{an} = -\frac{V_s}{2}, V_{bn} = 0, V_{cn} = \frac{V_s}{2}$$

Step 6: 5,6 conducting

$$V_{an} = 0, V_{bn} = -\frac{V_s}{2}, V_{cn} = \frac{V_s}{2}$$

120° conduction mode

Step	Thyristor conducting	V_{Rn}	V_{Yn}	V_{Bn}	\vec{v}
1	6,1	$V_s/2$	$-V_s/2$	0	$\frac{\sqrt{3}V_s}{2}(-30^\circ)$
2	1,2	$V_s/2$	0	$-V_s/2$	$\frac{\sqrt{3}V_s}{2}(30^\circ)$
3	2,3	0	$V_s/2$	$-V_s/2$	$\frac{\sqrt{3}V_s}{2}(90^\circ)$
4	3,4	$-V_s/2$	$V_s/2$	0	$\frac{\sqrt{3}V_s}{2}(150^\circ)$
5	4,5	$-V_s/2$	0	$V_s/2$	$\frac{\sqrt{3}V_s}{2}(210^\circ)$
6	5,6	0	$-V_s/2$	$V_s/2$	$\frac{\sqrt{3}V_s}{2}(-30^\circ)$

