

**LECTURE NOTES**  
**ON**  
**ELECTROMAGNETIC FIELD**  
**THEORY**

**2019 – 2020**

**II B. Tech I Semester (R15)**

**Dr. V.Bala Krishna Reddy, Professor**



**DEPARTMENT OF ELECTRICAL AND ELECTRONICS ENGINEERING**

**NARASARAOPETA ENGINEERING COLLEGE,  
NARASARAOPET**

**(Approved by AICTE, New Delhi & Affiliated to JNTUK, Kakinada)**

## **SYLLABUS**

### **UNIT – I     ELECTROSTATICS**

Sources and effects of electromagnetic fields – Coordinate Systems – Vector fields – Gradient, Divergence, Curl – theorems and applications

Electrostatic Fields - Coulomb's Law - Electric Field Intensity(EFI) due to Line, Surface and Volume charges- Work Done in Moving a Point Charge in Electrostatic Field-Electric Potential due to point charges, line charges and Volume Charges - Potential Gradient - Gauss's Law- Application of Gauss's Law-Maxwell's First Law – Numerical Problems.

Laplace's Equation and Poisson's Equations - Solution of Laplace's Equation in one Variable.

Electric Dipole - Dipole Moment - Potential and EFI due to Electric Dipole - Torque on an Electric Dipole in an Electric Field – Numerical Problems.

### **UNIT – II     CONDUCTORS AND DIELECTRICS**

Behavior of Conductors in an Electric Field-Conductors and Insulators – Electric Field inside a Dielectric Material – Polarization – Dielectric Conductors and Dielectric Boundary Conditions – Capacitance-Capacitance of Parallel Plate, Spherical & Co-axial capacitors – Energy Stored and Energy Density in a Static Electric Field – Current Density – Conduction and Convection Current Densities – Ohm's Law in Point Form – Equation of Continuity – Numerical Problems.

### **UNIT – III     MAGNETOSTATICS**

Static Magnetic Fields – Biot-Savart Law – Oerstead's experiment – Magnetic Field Intensity (MFI) due to a Straight, Circular & Solenoid Current Carrying Wire – Maxwell's Second Equation. Ampere's Circuital Law and its Applications Viz., MFI Due to an Infinite Sheet of Current and a Long Current Carrying Filament – Point Form of Ampere's Circuital Law – Maxwell's Third Equation – Numerical Problems.

Magnetic Force — Lorentz Force Equation – Force on Current Element in a Magnetic Field - Force on a Straight and Long Current Carrying Conductor in a Magnetic Field - Force Between two Straight and Parallel Current Carrying Conductors – Magnetic Dipole and Dipole moment – A Differential Current Loop as a Magnetic Dipole – Torque on a Current Loop Placed in a Magnetic Field – Numerical Problems.

### **UNIT - IV     MAGNETIC POTENTIAL**

Scalar Magnetic Potential and Vector Magnetic Potential and its Properties - Vector Magnetic Potential due to Simple Configuration – Vector Poisson's Equations.

Self and Mutual Inductances – Neumann's Formulae – Determination of Self Inductance of a Solenoid and Toroid and Mutual Inductance Between a Straight, Long Wire and a Square Loop Wire in the Same Plane – Energy Stored and Intensity in a Magnetic Field – Numerical Problems.

### **UNIT - V     TIME VARYING FIELDS**

Faraday's Law of Electromagnetic Induction – It's Integral and Point Forms – Maxwell's Fourth Equation. Statically and Dynamically Induced E.M.F's – Simple Problems – Modified Maxwell's Equations for Time Varying Fields – Displacement Current.

Wave Equations – Uniform Plane Wave Motion in Free Space, Conductors and Dielectrics – Velocity, Wave Length, Intrinsic Impedence and Skin Depth – Poynting Theorem – Poynting Vector and its Significance.

### **TEXT BOOKS:**

1 . Engineering Electromagnetics, William.H.Hayt, Mc.Graw Hill, 2010.

2. Principles of Electromagnetics, 6th Edition, Sadiku, Kulkarni, OXFORD University Press, 2015.

**REFERENCE BOOKS:**

1. Field Theory, K.A.Gangadhar, Khanna Publications, 2003.
2. Electromagnetics 5th edition, J.D.Kraus,Mc.Graw – Hill Inc, 1999.
3. Electromagnetics, Joseph Edminister, Tata Mc Graw Hill, 2006.

## UNIT – I

## ELECTROSTATICS

Sources and effects of electromagnetic fields – Coordinate Systems – Vector fields – Gradient, Divergence, Curl – theorems and applications. Electrostatic Fields - Coulomb's Law - Electric Field Intensity (EFI) due to Line, Surface and Volume charges- Work Done in Moving a Point Charge in Electrostatic Field-Electric Potential due to point charges, line charges and Volume Charges - Potential Gradient - Gauss's Law-Application of Gauss's Law-Maxwell's First Law – Numerical Problems.

Laplace's Equation and Poisson's Equations - Solution of Laplace's Equation in one Variable. Electric Dipole - Dipole Moment - Potential and EFI due to Electric Dipole - Torque on an Electric Dipole in an Electric Field – Numerical Problems.

### 1.2 Scalars and Vectors

The various quantities involved in the study of engineering electromagnetics can be classified as,

1. Scalars
- and
2. Vectors

#### 1.2.1 Scalar

The scalar is a quantity whose value may be represented by a single real number, which may be positive or negative. The direction is not at all required in describing a scalar. Thus,

A scalar is a quantity which is wholly characterized by its magnitude.

The various examples of scalar quantity are temperature, mass, volume, density, speed, electric charge etc.

#### 1.2.2 Vector

A quantity which has both, a magnitude and a specific direction in space is called a vector. In electromagnetics vectors defined in two and three dimensional spaces are required but vectors may be defined in n-dimensional space. Thus,

A vector is a quantity which is characterized by both, a magnitude and a direction.

The various examples of vector quantity are force, velocity, displacement, electric field intensity, magnetic field intensity, acceleration etc.

#### 1.2.3 Scalar Field

A field is a region in which a particular physical function has a value at each and every point in that region. The distribution of a scalar quantity with a definite position in a space is called **scalar field**. For example the temperature of atmosphere. It has a definite value in the atmosphere but no need of direction to specify it hence it is a scalar field. The height of surface of earth above sea level is a scalar field. Few other examples of scalar field are sound intensity in an auditorium, light intensity in a room, atmospheric pressure in a given region etc.

#### 1.2.4 Vector Field

If a quantity which is specified in a region to define a field is a vector then the corresponding field is called a **vector field**. For example the gravitational force on a mass

in a space is a vector field. This force has a value at various points in a space and always has a specific direction.

The other examples of vector field are the velocity of particles in a moving fluid, wind velocity of atmosphere, voltage gradient in a cable, displacement of a flying bird in a space, magnetic field existing from north to south field etc.

### 1.3 Representation of a Vector

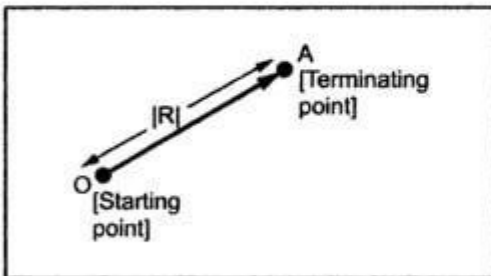


Fig. 1.1 Representation of a vector

In two dimensions, a vector can be represented by a straight line with an arrow in a plane. This is shown in the Fig. 1.1. The length of the segment is the magnitude of a vector while the arrow indicates the direction of the vector in a given co-ordinate system. The vector shown in the Fig. 1.1 is symbolically denoted as  $\overline{OA}$ . The point O is its starting point while A is its terminating point. Its length is called its magnitude, which is R for the vector OA shown. It is represented as  $|\overline{OA}| = R$ . It

is the distance between the starting point and terminating point of a vector.

**Key Point:** The vector hereafter will be indicated by bold letter with a bar over it.

#### 1.3.1 Unit Vector

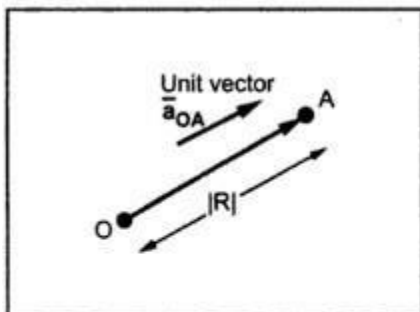


Fig. 1.2 Unit vector

A unit vector has a function to indicate the direction. Its magnitude is always unity, irrespective of the direction which it indicates and the co-ordinate system under consideration. Thus for any vector, to indicate its direction a unit vector can be used. Consider a unit vector  $\bar{a}_{OA}$  in the direction of  $\overline{OA}$  as shown in the Fig. 1.2. This vector indicates the direction of  $\overline{OA}$  but its magnitude is unity.

So vector  $\overline{OA}$  can be represented completely as its magnitude R and the direction as indicated by unit

vector along its direction.

$$\therefore \overline{OA} = |\overline{OA}| \bar{a}_{OA} = R \bar{a}_{OA}$$

where  $\bar{a}_{OA}$  = Unit vector along the direction OA and  $|\bar{a}_{OA}| = 1$

**Key Point:** Hereafter, letter  $\bar{a}$  is used to indicate the unit vector and its suffix indicates the direction of the unit vector. Thus  $\bar{a}_x$  indicates the unit vector along x axis direction.

In case if a vector is known then the unit vector along that vector can be obtained by dividing the vector by its magnitude. Thus unit vector can be expressed as,

## 1.4 Vector Algebra

The various mathematical operations such as addition, subtraction, multiplication etc. can be performed with the vectors. In this section the following mathematical operations with the vectors are discussed.

1. Scaling
2. Addition
3. Subtraction

### 1.4.1 Scaling of Vector

This is nothing but, multiplication by a scalar to a vector. Such a multiplication changes the magnitude (length) of a vector but not its direction, when the scalar is positive.

Let  $\alpha$  = Scalar with which vector is to be multiplied

Then if  $\alpha > 1$  then the magnitude of a vector increases but direction remains same, when multiplied. This is shown in the Fig. 1.3 (a). If  $\alpha < 1$  then the magnitude of a vector decreases but direction remains same, when multiplied. This is shown in the Fig. 1.3 (b).

If  $\alpha = -1$  then the magnitude remains same but direction of the vector reverses, when multiplied. This is shown in the Fig. 1.3 (c).

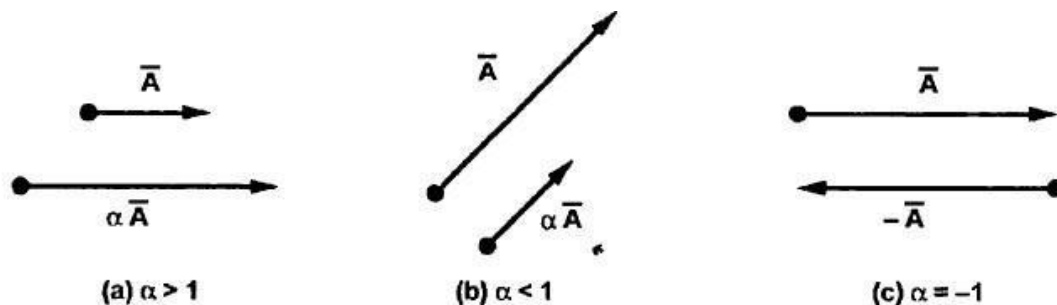
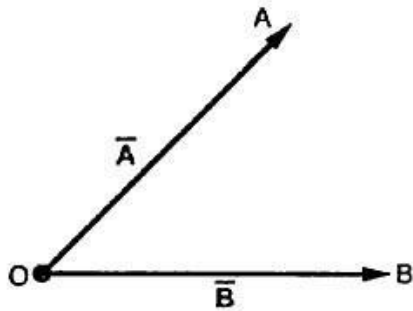


Fig. 1.3 Multiplication by a scalar

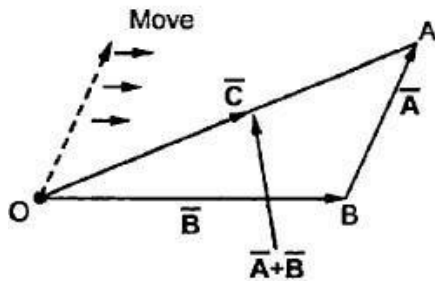
**Key Point:** Thus if  $\alpha$  is negative, the magnitude of vector changes by  $\alpha$  times while the direction becomes exactly opposite to the original vector, after multiplication.

### 1.4.2 Addition of Vectors

Consider two coplanar vectors as shown in the Fig. 1.4. The vectors which lie in the same plane are called coplanar vectors.



**Fig. 1.4 Coplanar vectors**



**Fig. 1.5 Addition of vectors**

Let us find the sum of these two vectors  $\vec{A}$  and  $\vec{B}$ , shown in the Fig. 1.4.

The procedure is to move one of the two vectors parallel to itself at the tip of the other vector. Thus move  $\vec{A}$ , parallel to itself at the tip of  $\vec{B}$ .

Then join tip of  $\vec{A}$  moved, to the origin. This vector represents resultant which is the addition of the two vectors  $\vec{A}$  and  $\vec{B}$ . This is shown in the Fig. 1.5.

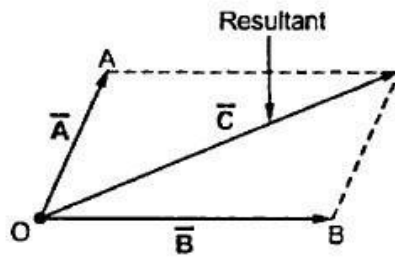
Let us denote this resultant as  $\vec{C}$  then

$$\vec{C} = \vec{A} + \vec{B}$$

It must be remembered that the direction of  $\vec{C}$  is from origin O to the tip of the vector moved.

Another point which can be noticed that if  $\vec{B}$  is moved parallel to itself at the tip of  $\vec{A}$ , we get the same resultant  $\vec{C}$ . Thus, the order of the addition is not important. The addition of vectors obeys the commutative law i.e.  $\vec{A} + \vec{B} = \vec{B} + \vec{A}$ .

Another method of performing the addition of vectors is the **parallelogram rule**. Complete the parallelogram as shown in the Fig. 1.6. Then the diagonal of the parallelogram represents the addition of the two vectors.



**Fig. 1.6 Parallelogram rule for addition**

By using any of these two methods not only two but any number of vectors can be added to obtain the resultant. For example, consider four vectors as shown in the Fig. 1.7(a). These can be added by shifting these vectors one by one to the tip of other vectors to complete the polygon. The vector joining origin O to the tip of the last shifted vector represents the sum, as shown in the Fig. 1.7 (b). This method is called **head to tail rule** of addition of vectors.

Once the co-ordinate systems are defined, then the vectors can be expressed in terms of the components along the axes of the co-ordinate system. Then by adding the corresponding components of the vectors, the components of the resultant vector which is



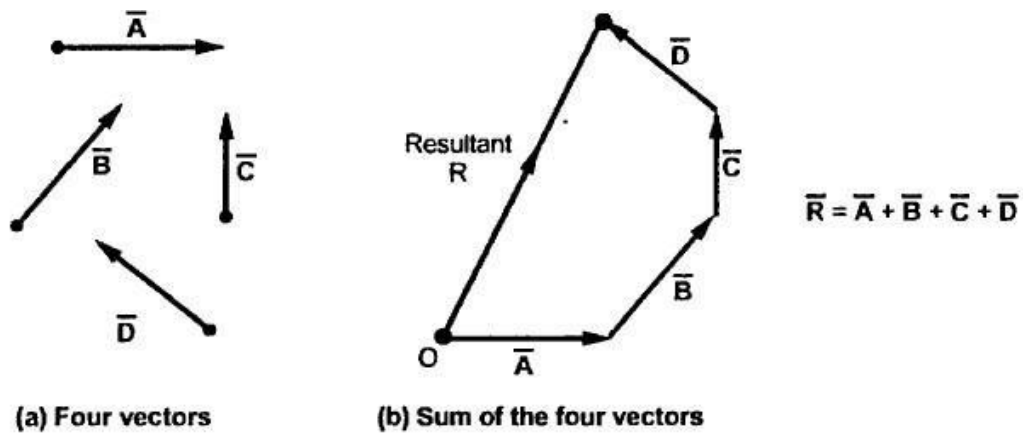


Fig. 1.7

the addition of the vectors, can be obtained. This method is explained after the co-ordinate systems are discussed.

The following basic laws of algebra are obeyed by the vectors  $\vec{A}$ ,  $\vec{B}$  and  $\vec{C}$  :

Law	Addition	Multiplication by scalar
Commutative	$\vec{A} + \vec{B} = \vec{B} + \vec{A}$	$\alpha \vec{A} = \vec{A} \alpha$
Associative	$\vec{A} + (\vec{B} + \vec{C}) = (\vec{A} + \vec{B}) + \vec{C}$	$\beta (\alpha \vec{A}) = (\beta \alpha) \vec{A}$
Distributive	$\alpha (\vec{A} + \vec{B}) = \alpha \vec{A} + \alpha \vec{B}$	$(\alpha + \beta) \vec{A} = \alpha \vec{A} + \beta \vec{A}$

### 1.4.3 Subtraction of Vectors

The subtraction of vectors can be obtained from the rules of addition. If  $\vec{B}$  is to be subtracted from  $\vec{A}$  then based on addition it can be represented as,

$$\vec{C} = \vec{A} + (-\vec{B})$$

Thus reverse the sign of  $\vec{B}$  i.e. reverse its direction by multiplying it with  $-1$  and then add it to  $\vec{A}$  to obtain the subtraction. This is shown in the Fig. 1.8 (a) and (b).

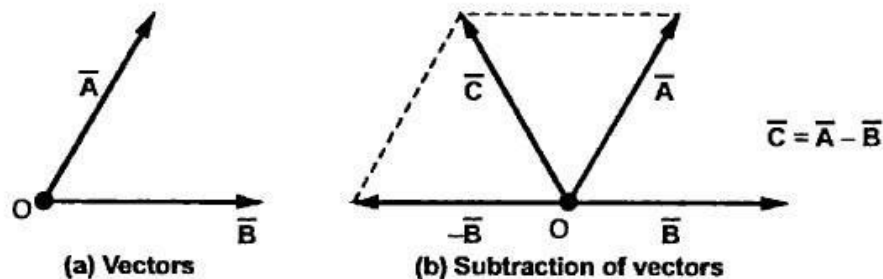


Fig. 1.8

### 1.4.3.1 Identical Vectors

Two vectors are said to be **identical** if their difference is zero. Thus  $\vec{A}$  and  $\vec{B}$  are identical if  $\vec{A} - \vec{B} = 0$  i.e.  $\vec{A} = \vec{B}$ . Such two vectors are also called **equal vectors**.

## 1.5 The Co-ordinate Systems

To describe a vector accurately and to express a vector in terms of its components, it is necessary to have some reference directions. Such directions are represented in terms of various co-ordinate systems. There are various coordinate systems available in mathematics, out of which three co-ordinate systems are used in this book, which are

1. Cartesian or rectangular co-ordinate system
2. Cylindrical co-ordinate system
3. Spherical co-ordinate system

Let us discuss these systems in detail.

### 1.6 Cartesian Co-ordinate System

This is also called **rectangular co-ordinate system**. This system has three co-ordinate axes represented as  $x$ ,  $y$  and  $z$  which are mutually at right angles to each other. These three axes intersect at a common point called **origin** of the system. There are two types of such system called

## 1. Right handed system and 2. Left handed system.

The right handed system means if  $x$  axis is rotated towards  $y$  axis through a smaller angle, then this rotation causes the upward movement of right handed screw in the  $z$  axis direction. This is shown in the Fig. 1.9 (a). In this system, if right hand is used then thumb indicates  $x$  axis, the forefinger indicates  $y$  axis and middle finger indicates  $z$  axis, when three fingers are held mutually perpendicular to each other.

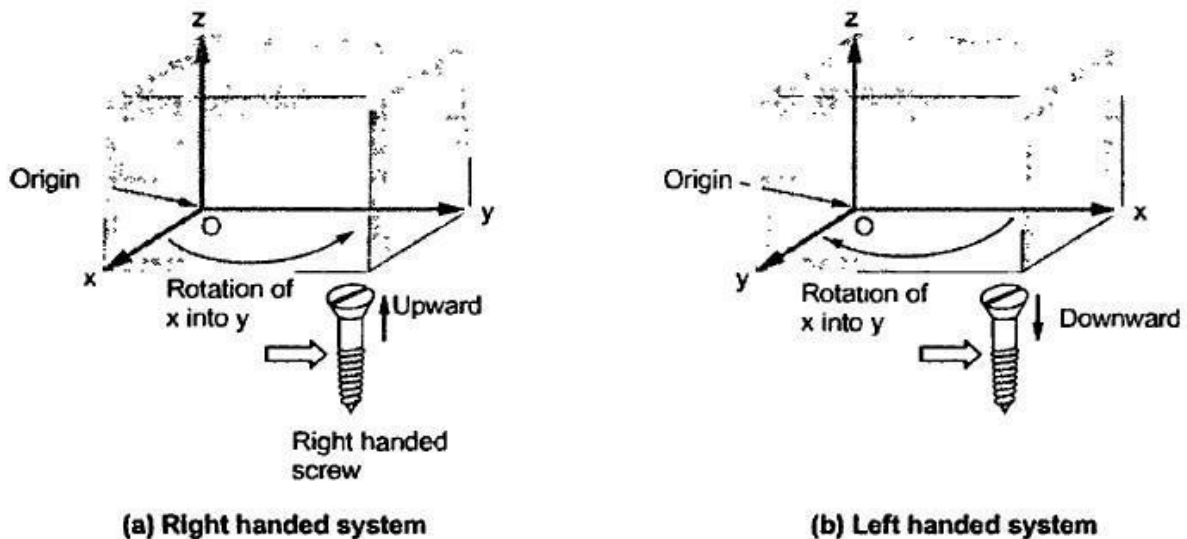


Fig. 1.9

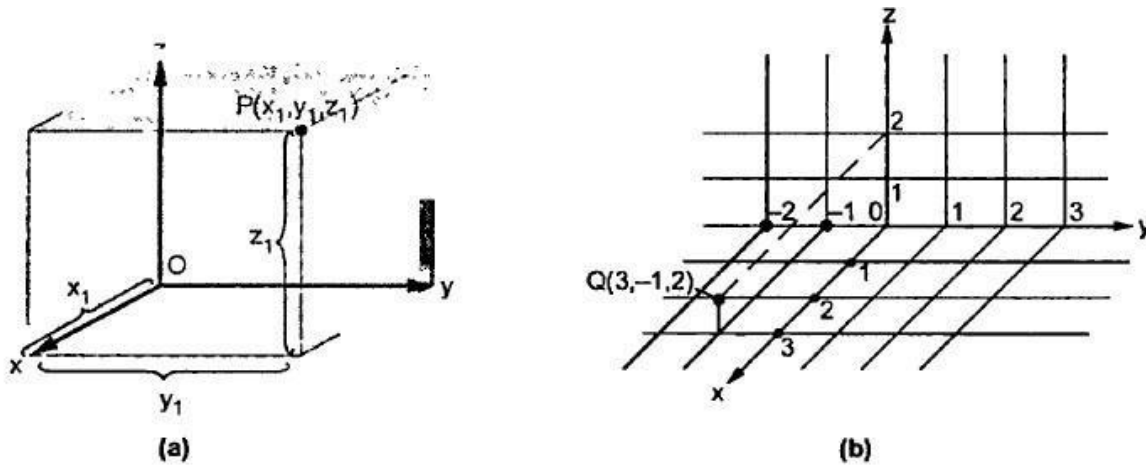
In left handed system  $x$  and  $y$  axes are interchanged compared to right handed system. This means the rotation of  $x$  axis into  $y$  axis through smaller angle causes the downward movement of right handed screw in the  $z$  axis direction. This is shown in the Fig. 1.9 (b).

**Key Point:** *The right handed system is very commonly used and followed in this book.*

In cartesian co-ordinate system  $x = 0$  plane indicates two dimensional  $y$ - $z$  plane,  $y = 0$  plane indicates two dimensional  $x$ - $z$  plane and  $z = 0$  plane indicates two dimensional  $x$ - $y$  plane.

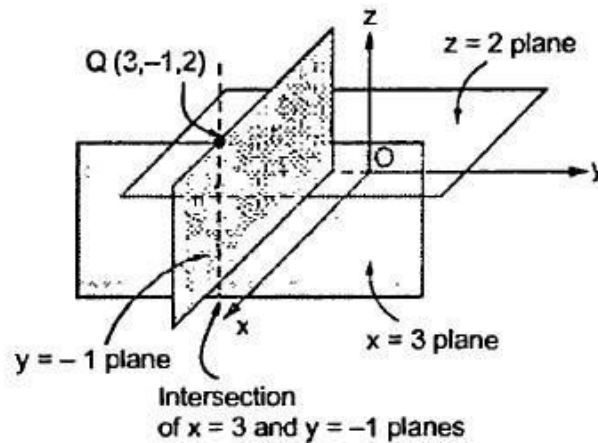
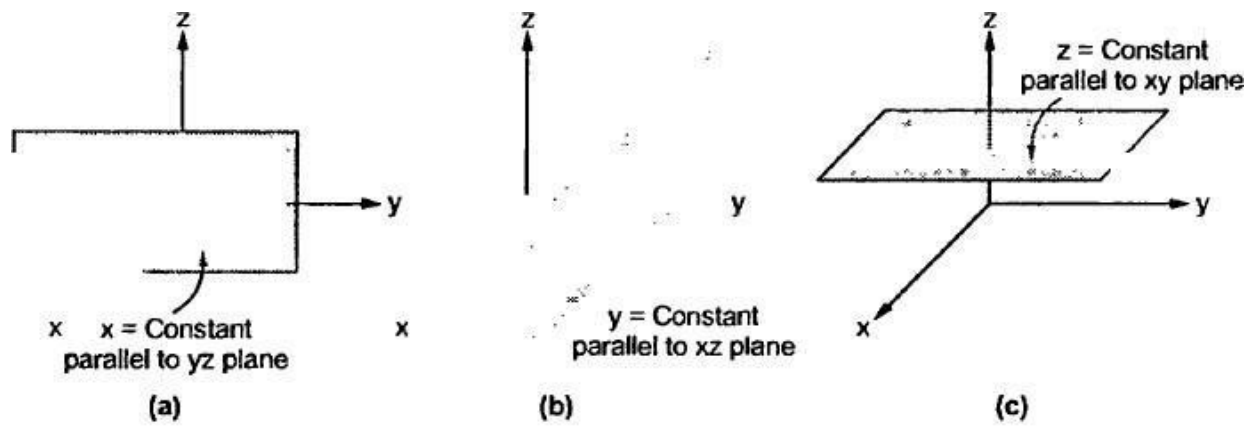
### 1.6.1 Representing a Point in Rectangular Co-ordinate System

A point in rectangular co-ordinate system is located by three co-ordinates namely  $x$ ,  $y$  and  $z$  co-ordinates. The point can be reached by moving from origin, the distance  $x$  in  $x$  direction then the distance  $y$  in  $y$  direction and finally the distance  $z$  in  $z$  direction. Consider a point  $P$  having co-ordinates  $x_1, y_1$  and  $z_1$ . It is represented as  $P(x_1, y_1, z_1)$ . It can be shown as in the Fig. 1.10 (a). The co-ordinates  $x_1, y_1$  and  $z_1$  can be positive or negative. The point  $Q(3, -1, 2)$  can be shown in this system as in the Fig. 1.10 (b).



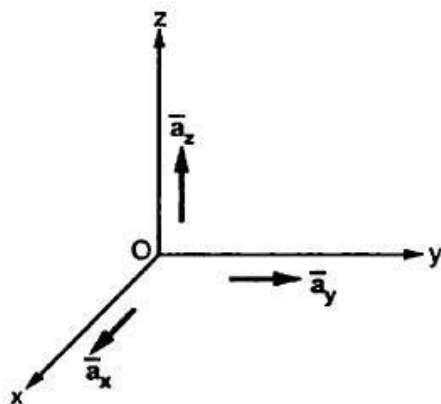
**Fig. 1.10 Representing a point in cartesian system**

Another method to define a point is to consider three surfaces namely  $x = \text{constant}$ ,  $y = \text{constant}$  and  $z = \text{constant}$  planes. The common intersection point of these three surfaces is the point to be defined and the constants indicate the coordinates of that point. For example, consider point Q which is intersection of three planes namely  $x = 3$  plane,  $y = -1$  plane and  $z = 2$  plane. The planes  $x = \text{constant}$ ,  $y = \text{constant}$  and  $z = \text{constant}$  are shown in the Fig. 1.11. The constants may be positive or negative.



### 1.6.2 Base Vectors

The **base vectors** are the unit vectors which are strictly oriented along the directions of the co-ordinate axes of the given co-ordinate system.



**Fig. 1.12 Unit vectors in cartesian system**

Thus for cartesian co-ordinate system, the three base vectors are the unit vectors oriented in  $x$ ,  $y$  and  $z$  axis of the system. So  $\bar{a}_x$ ,  $\bar{a}_y$  and  $\bar{a}_z$  are the base vectors of cartesian co-ordinate system. These are shown in the Fig. 1.12.

So any point on  $x$ -axis having co-ordinates  $(x_1, 0, 0)$  can be represented by a vector joining origin to this point and denoted as  $x_1 \bar{a}_x$ .

The base vectors are very important in representing a vector in terms of its components, along the three co-ordinate axes.

### 1.6.4 Differential Elements in Cartesian Co-ordinate System

Consider a point  $P(x, y, z)$  in the rectangular co-ordinate system. Let us increase each co-ordinate by a differential amount. A new point  $P'$  will be obtained having co-ordinates  $(x+dx, y+dy, z+dz)$ .

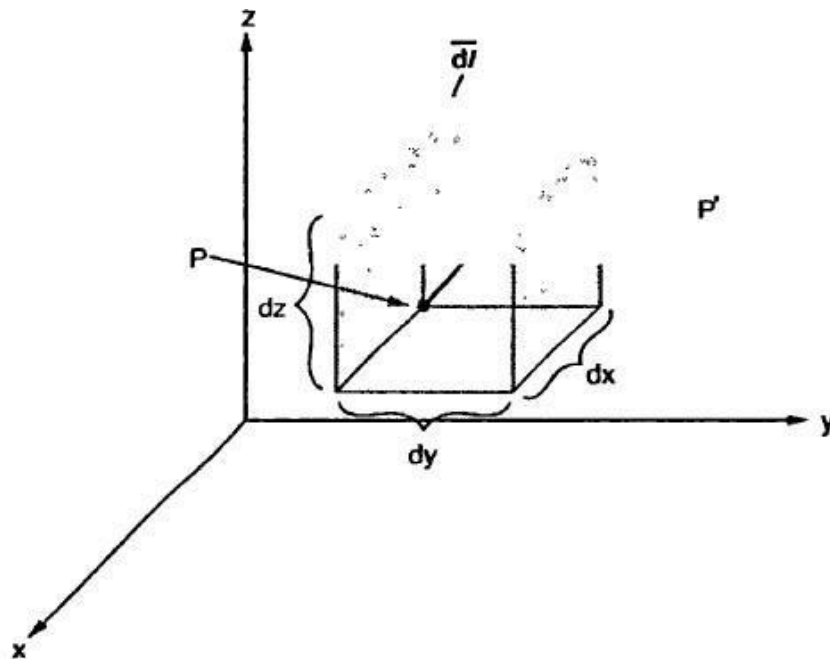
Thus,  $dx =$  Differential length in  $x$  direction  
 $dy =$  Differential length in  $y$  direction  
 $dz =$  Differential length in  $z$  direction

Hence differential vector length also called elementary vector length can be represented as,

$$\overline{dl} = dx \overline{a}_x + dy \overline{a}_y + dz \overline{a}_z \quad \dots (6)$$

This is the vector joining original point  $P$  to new point  $P'$ .

Now point  $P$  is the intersection of three planes while point  $P'$  is the intersection of three new planes which are slightly displaced from original three planes. These six planes together define a differential volume which is a rectangular parallelepiped as shown in the Fig. 1.15. The diagonal of this parallelepiped is the differential vector length.



**Fig. 1.15 Differential elements and different length in cartesian system**

The distance of  $P'$  from  $P$  is given by magnitude of the differential vector length,

$$|\overline{dl}| = \sqrt{(dx)^2 + (dy)^2 + (dz)^2} \quad \dots (7)$$

Hence the **differential volume** of the rectangular parallelepiped is given by,

$$\boxed{dv = dx \, dy \, dz} \quad \dots(8)$$

Note that  $\bar{dl}$  is a vector but  $dv$  is a scalar.

Let us define **differential surface areas**. The differential surface element  $\bar{dS}$  is represented as,

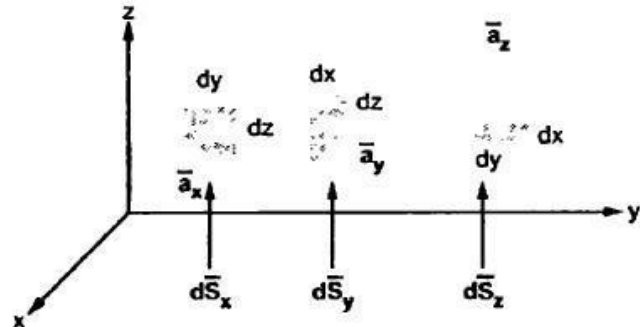
$$\boxed{d\bar{S} = dS \bar{a}_n} \quad \dots(9)$$

where  $dS$  = Differential surface area of the element

$\bar{a}_n$  = Unit vector normal to the surface  $dS$

Thus various differential surface elements in cartesian co-ordinate system are shown in the Fig. 1.16.

The vector representation of these elements is given as,



**Fig. 1.16 Differential surface elements in cartesian system**

$$\begin{aligned} d\bar{S}_x &= \text{Differential vector surface area normal to } x \text{ direction} \\ &= dydz \bar{a}_x \end{aligned} \quad \dots (10)$$

$$\begin{aligned} d\bar{S}_y &= \text{Differential vector surface area normal to } y \text{ direction} \\ &= dx dz \bar{a}_y \end{aligned} \quad \dots (11)$$

$$\begin{aligned} d\bar{S}_z &= \text{Differential vector surface area normal to } z \text{ direction} \\ &= dx dy \bar{a}_z \end{aligned} \quad \dots (12)$$

The differential elements play very important role in the study of engineering electromagnetics.

## 1.7 Cylindrical Co-ordinate System

The circular cylindrical co-ordinate system is the three dimensional version of polar co-ordinate system. The surfaces used to define the cylindrical co-ordinate system are,

1. Plane of constant  $z$  which is parallel to  $xy$  plane.
  2. A cylinder of radius  $r$  with  $z$  axis as the axis of the cylinder.
  3. A half plane perpendicular to  $xy$  plane and at an angle  $\phi$  with respect to  $xz$  plane.
- The angle  $\phi$  is called **azimuthal angle**.

The ranges of the variables are,

$$0 \leq r \leq \infty$$

... (1)

$$0 \leq \phi \leq 2\pi$$

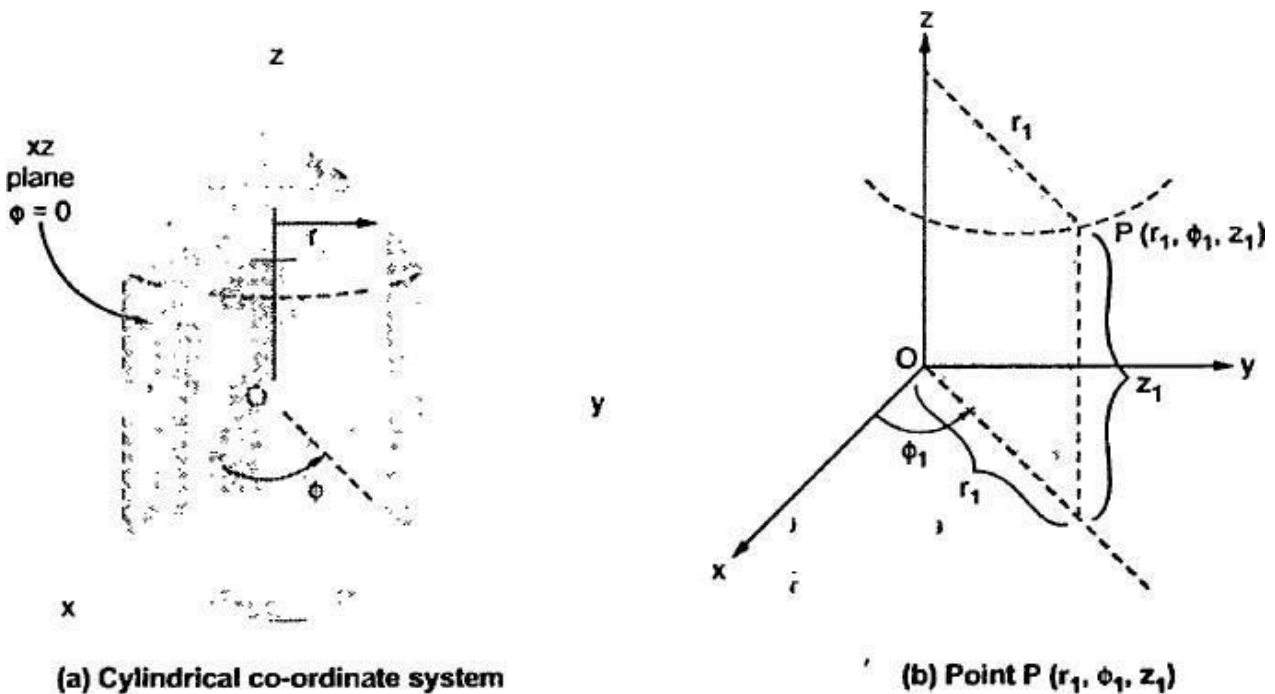
... (2)

$$-\infty < z \leq \infty$$

... (3)

The point P in cylindrical co-ordinate system has three co-ordinates  $r$ ,  $\phi$  and  $z$  whose values lie in the respective ranges given by the equations (1), (2) and (3).

The point  $P(r, \phi, z)$  can be shown as in the Fig. 1.17(b).



**Fig. 1.17**

The point P can be defined as the intersection of three surfaces in cylindrical co-ordinate system. These three surfaces are,

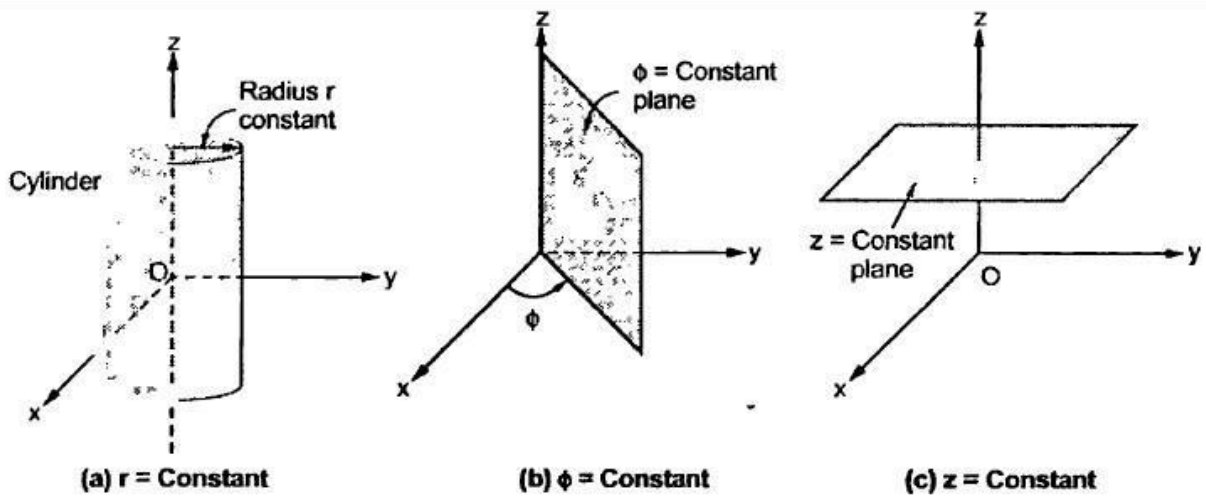
$r = \text{Constant}$  which is a circular cylinder with  $z$  axis as its axis.

$\phi = \text{Constant}$  plane which is a vertical plane perpendicular to  $xy$  plane making angle  $\phi$  with respect to  $xz$  plane.

$z = \text{Constant}$  plane is a plane parallel to  $xy$  plane.

These surfaces are shown in the Fig. 1.18.

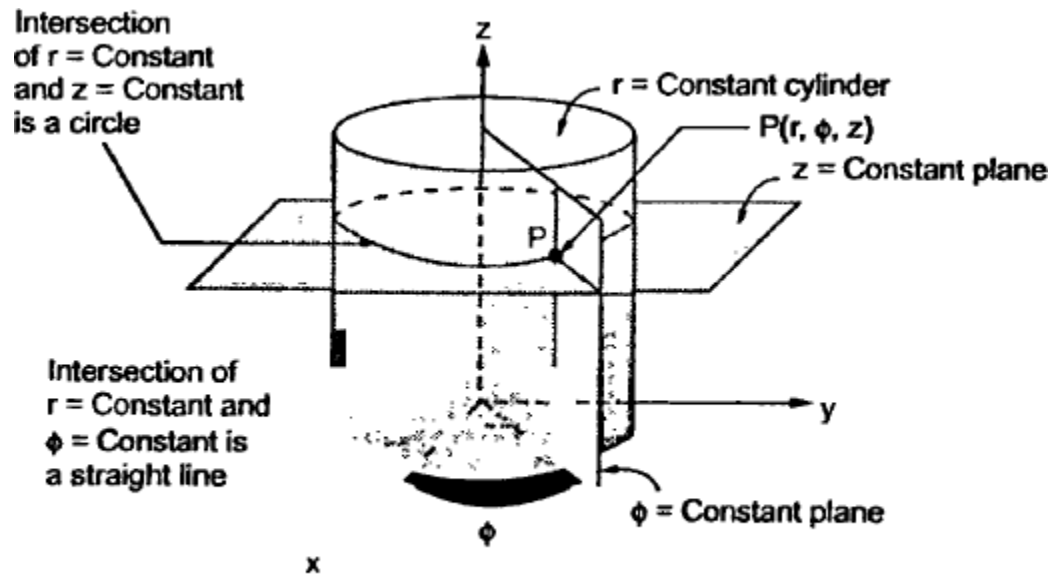




**Fig. 1.18**

The intersection of any two surfaces out of the above three surfaces is either a line or a circle and intersection of three surfaces defines a point P.

The intersection of  $z = \text{constant}$  and  $r = \text{constant}$  is a circle. The intersection of  $\phi = \text{constant}$  and  $r = \text{constant}$  is a line. The point P which is intersection of all three surfaces is shown in the Fig. 1.19.

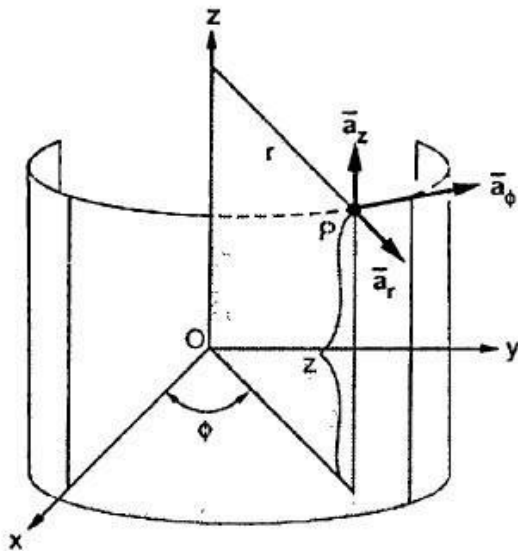


**Fig. 1.19 Representing point P in cylindrical system**

### 1.7.1 Base Vectors

Similar to cartesian coordinate system, there are three unit vectors in the  $r$ ,  $\phi$  and  $z$  directions denoted as  $\bar{a}_r$ ,  $\bar{a}_\phi$  and  $\bar{a}_z$ .

These unit vectors are shown in the Fig. 1.20.



**Fig. 1.20 Unit vectors in cylindrical system**

These are mutually perpendicular to each other.

The  $\bar{a}_r$  lies in a plane parallel to the  $xy$  plane and is perpendicular to the surface of the cylinder at a given point, coming radially outward.

The unit vector  $\bar{a}_\phi$  lies also in a plane parallel to the  $xy$  plane but it is tangent to the cylinder and pointing in a direction of increasing  $\phi$  at the given point.

The unit vector  $\bar{a}_z$  is parallel to  $z$  axis and directed towards increasing  $z$ .

Hence vector of point  $P$  can be represented as,

$$\bar{P} = P_r \bar{a}_r + P_\phi \bar{a}_\phi + P_z \bar{a}_z \quad \dots (4)$$

### 1.7.2 Differential Elements in Cylindrical Co-ordinate System

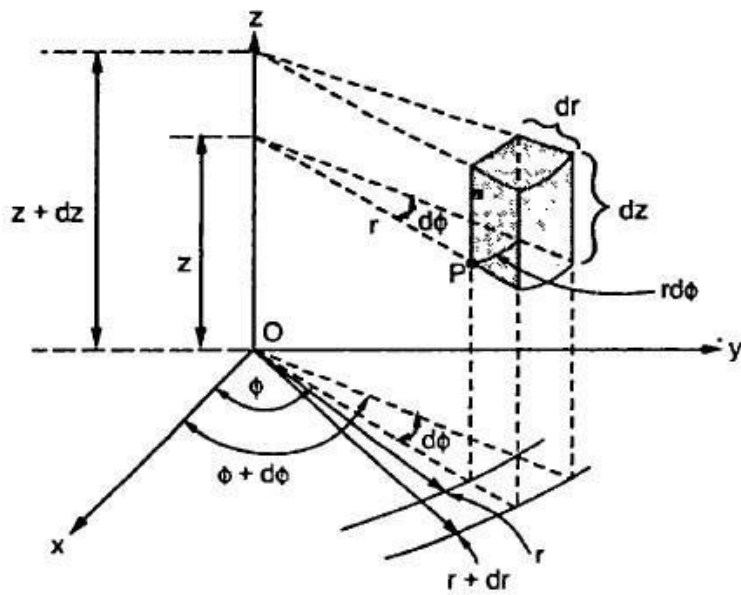
Consider a point  $P(r, \phi, z)$  in a cylindrical co-ordinate system. Let each co-ordinate is increased by the differential amount. The differential increments in  $r, \phi, z$  are  $dr, d\phi$  and  $dz$  respectively.

Now there are two cylinders of radius  $r$  and  $r+dr$ . There are two radial planes at the angles  $\phi$  and  $\phi+d\phi$ . And there are two horizontal planes at the heights  $z$  and  $z+dz$ . All these surfaces enclose a small volume as shown in the Fig. 1.21.

The differential lengths in  $r$  and  $z$  directions are  $dr$  and  $dz$  respectively. In  $\phi$  direction,  $d\phi$  is the change in angle  $\phi$  and is not the differential length. Due to this change  $d\phi$ , there exists a differential arc length in  $\phi$  direction. This differential length, due to  $d\phi$ , in  $\phi$  direction is  $r d\phi$  as shown in the Fig. 1.21.

Thus the differential lengths are,

$$dr = \text{Differential length in } r \text{ direction} \quad \dots (5)$$



**Fig. 1.21 Differential volume in cylindrical co-ordinate system**

$$r \, d\phi = \text{Differential length in } \phi \text{ direction} \quad \dots (6)$$

$$dz = \text{Differential length in } z \text{ direction} \quad \dots (7)$$

Hence the **differential vector length** in cylindrical co-ordinate system is given by,

$$\boxed{\bar{dl} = dr \bar{a}_r + r \, d\phi \bar{a}_\phi + dz \bar{a}_z} \quad \dots (8)$$

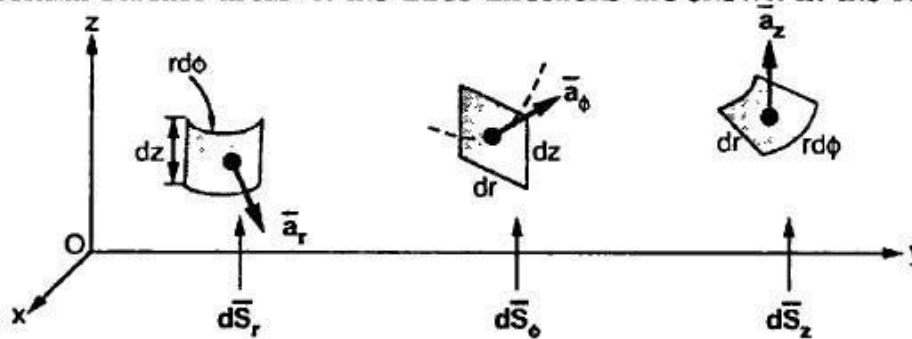
The magnitude of the differential length vector is given by,

$$|\bar{dl}| = \sqrt{(dr)^2 + (r d\phi)^2 + (dz)^2} \quad \dots (9)$$

Hence the differential volume of the differential element formed is given by,

$$dv = r dr d\phi dz \quad \dots (10)$$

The differential surface areas in the three directions are shown in the Fig. 1.22.



**Fig. 1.22 Differential surface elements in cylindrical system**

The vector representation of these differential surface areas are given by,

$$\begin{aligned} d\bar{S}_r &= \text{Differential vector surface area normal to } r \text{ direction} \\ &= r d\phi dz \bar{a}_r \end{aligned} \quad \dots (11)$$

$$\begin{aligned} d\bar{S}_\phi &= \text{Differential vector surface area normal to } \phi \text{ direction} \\ &= dr dz \bar{a}_\phi \end{aligned} \quad \dots (12)$$

$$\begin{aligned} d\bar{S}_z &= \text{Differential vector surface area normal to } z \text{ direction} \\ &= r dr d\phi \bar{a}_z \end{aligned} \quad \dots (13)$$

## 1.8 Spherical Co-ordinate System

The surfaces which are used to define the spherical co-ordinate system on the three cartesian axes are,

1. Sphere of radius  $r$ , origin as the centre of the sphere.
2. A right circular cone with its apex at the origin and its axis as  $z$  axis. Its half angle is  $\theta$ . It rotates about  $z$  axis and  $\theta$  varies from  $0$  to  $180^\circ$ .
3. A half plane perpendicular to  $xy$  plane containing  $z$  axis, making an angle  $\phi$  with the  $xz$  plane.

Thus the three co-ordinates of a point  $P$  in the spherical co-ordinate system are  $(r, \theta, \phi)$ . These surfaces are shown in the Fig. 1.25.

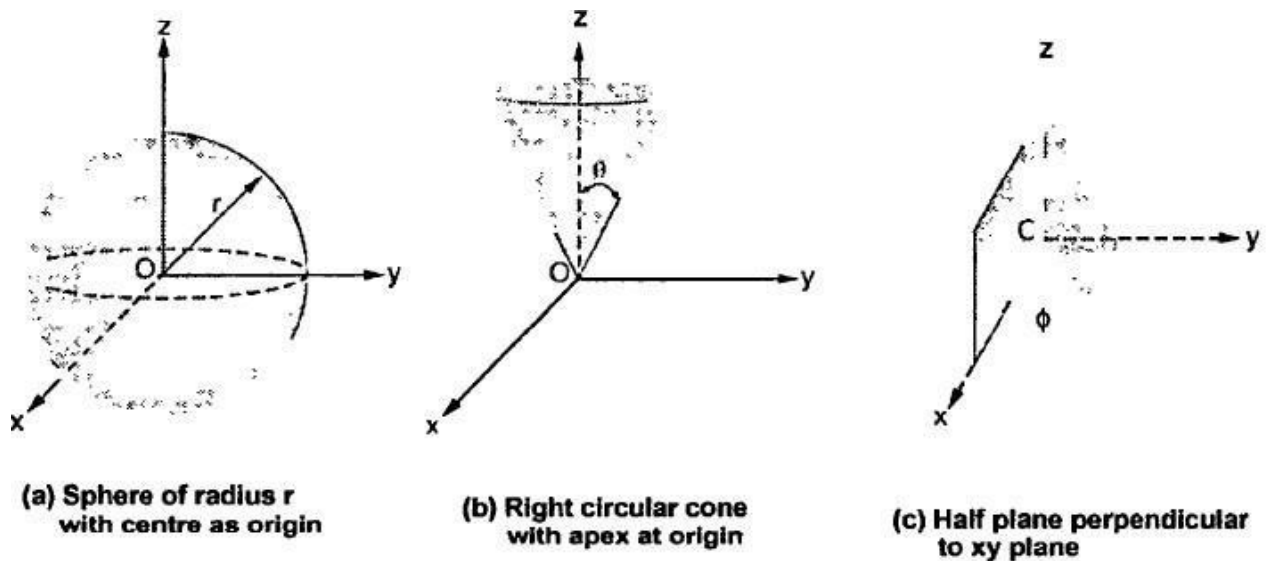


Fig. 1.25

The ranges of the variables are,

$$0 \leq r < \infty \quad \dots (1)$$

$$0 \leq \phi \leq 2\pi \quad \dots (2)$$

$$0 \leq \theta \leq \pi \text{ as half angle} \quad \dots (3)$$

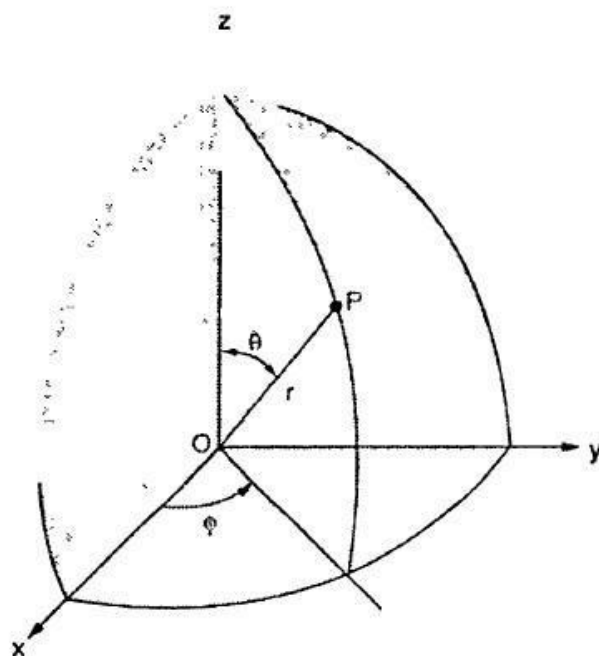


Fig. 1.26 Representing point  $P$  in spherical co-ordinate system

from the Fig. 1.27, the radius of this circle is  $r \sin \theta$

The point  $P(r, \theta, \phi)$  can be represented in the spherical co-ordinate system as shown in the Fig. 1.26. The angles  $\theta$  and  $\phi$  are measured in radians.

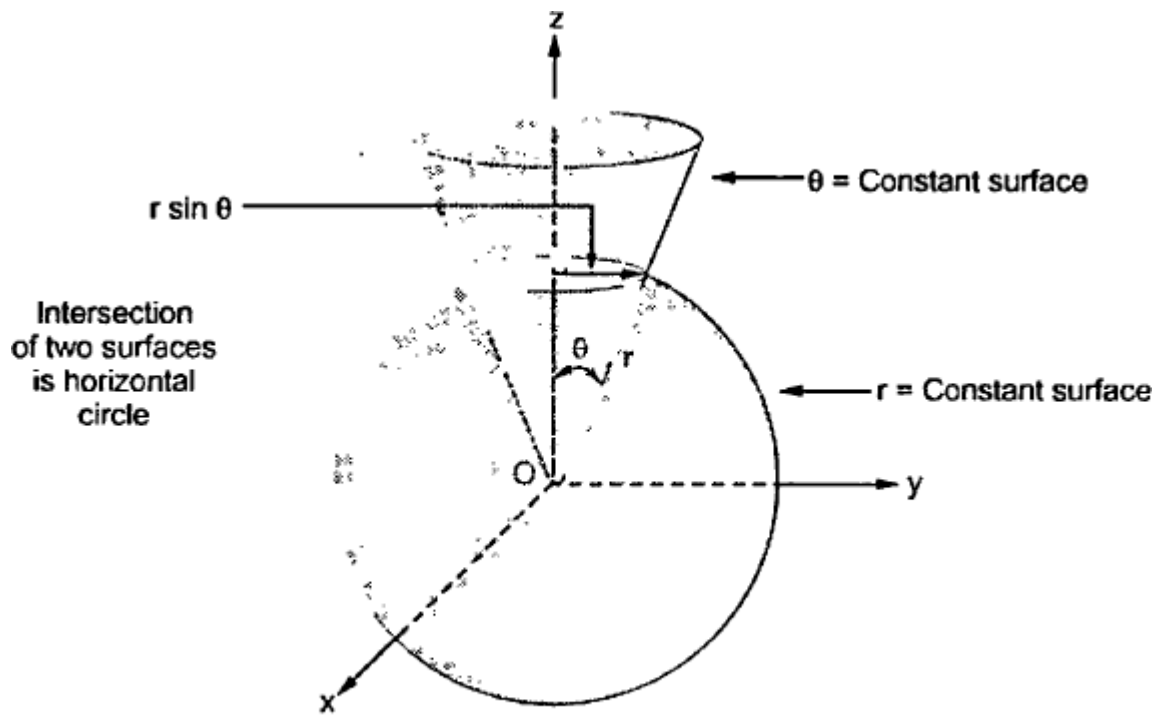
The point  $P$  can be defined as the intersection of three surfaces in spherical co-ordinate system. These three surfaces are,

$r = \text{Constant}$  which is a sphere with centre as origin.

$\theta = \text{Constant}$  which is right circular cone with apex as origin and axis as  $z$  axis.

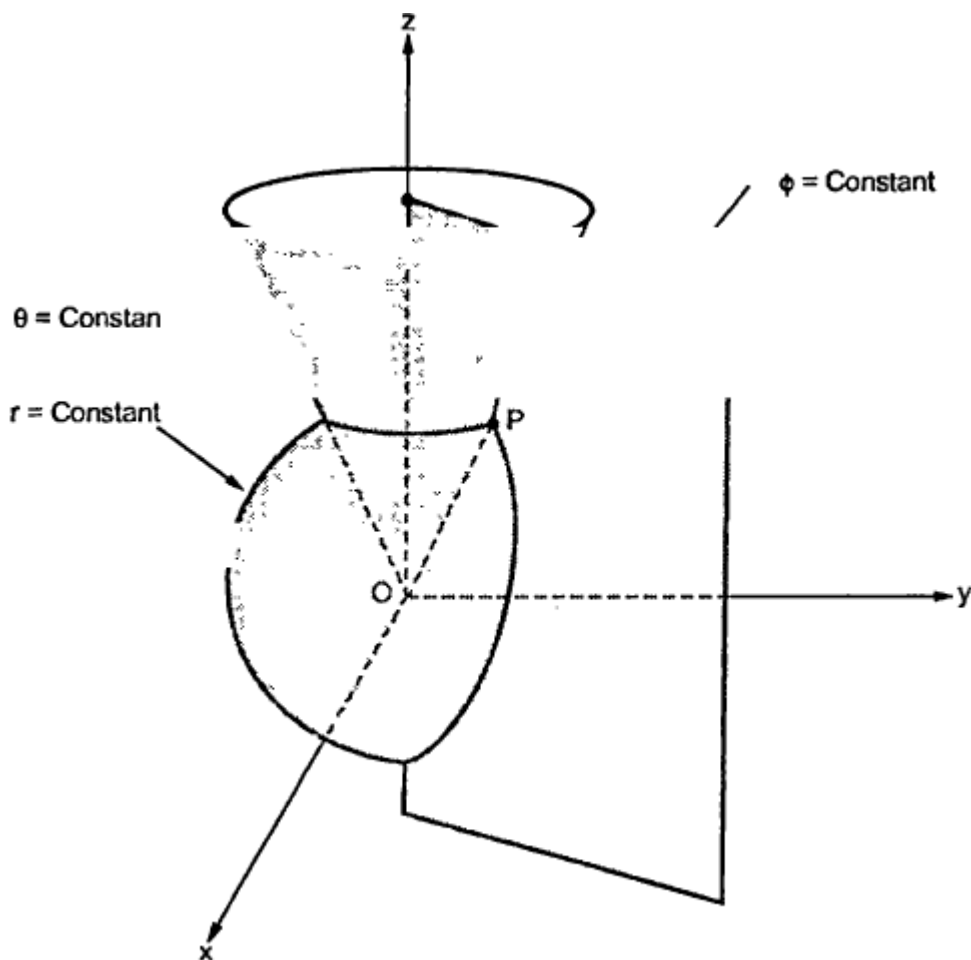
$\phi = \text{Constant}$  is a plane perpendicular to  $xy$  plane.

The surfaces are already shown in the Fig. 1.25. The intersection of the sphere i.e.  $r = \text{Constant}$  surface and right circular cone i.e.  $\theta = \text{Constant}$  surface is a horizontal circle as shown in the Fig. 1.27. As seen



**Fig. 1.27**

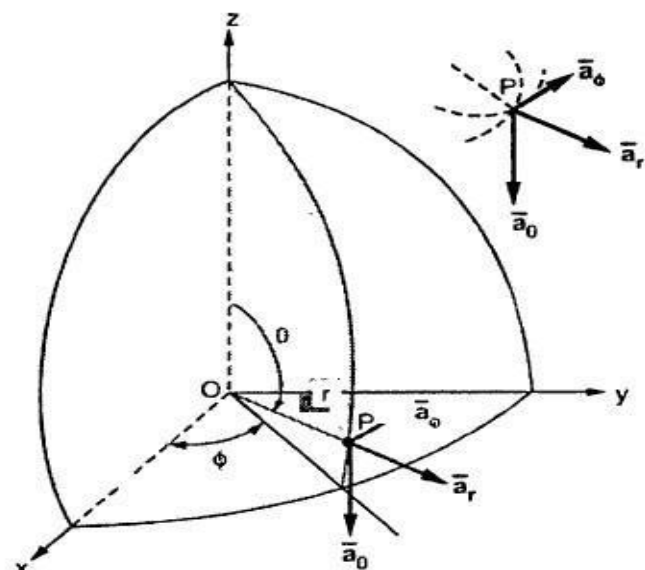
Now consider intersection of  $\phi = \text{constant}$  plane with the intersection of  $r = \text{constant}$  and  $\theta = \text{constant}$  planes as shown in the Fig. 1.28. This defines a point P.



**Fig. 1.28 Representing point P in spherical co-ordinate system**

### 1.8.1 Base Vectors

Similar to other two co-ordinate systems, there are three unit vectors in the  $r$ ,  $\theta$  and  $\phi$  directions denoted as  $\bar{a}_r$ ,  $\bar{a}_\theta$  and  $\bar{a}_\phi$ . These unit vectors are mutually perpendicular to each other and are shown in the Fig.1.29. The unit vector  $\bar{a}_r$  is directed from the centre of the sphere i.e. origin to the given point P. It is directed radially outward, normal to the sphere. It lies in the cone  $\theta = \text{constant}$  and plane  $\phi = \text{constant}$ .



**Fig. 1.29 Unit vectors in spherical co-ordinate systems**

The unit vector  $\bar{a}_\theta$  is tangent to the sphere and oriented in the direction of increasing  $\theta$ . It is normal to the conical surface.

The third unit vector  $\bar{a}_\phi$  is tangent to the sphere and also tangent to the conical surface. It is oriented in the direction of increasing  $\phi$ . It is same as defined in the cylindrical co-ordinate system.

Hence vector of point P can be represented as,

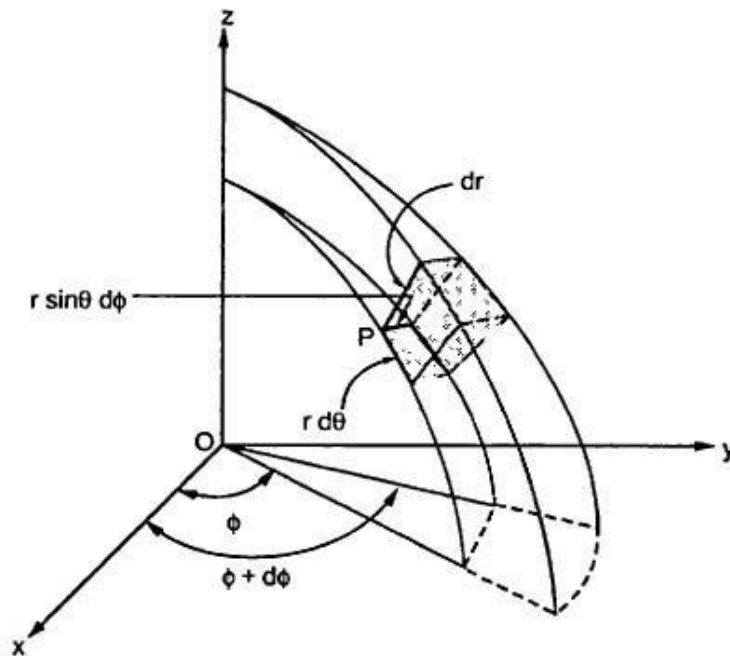
$$\bar{P} = P_r \bar{a}_r + P_\theta \bar{a}_\theta + P_\phi \bar{a}_\phi \quad \dots (4)$$

where  $P_r$  is the radius  $r$  and  $P_\theta, P_\phi$  are the two angle components of point P.

### 1.8.2 Differential Elements in Spherical Co-ordinate System

Consider a point  $P(r, \theta, \phi)$  in a spherical co-ordinate system. Let each co-ordinate is increased by the differential amount. The differential increments in  $r, \theta, \phi$  are  $dr, d\theta$  and  $d\phi$ .

Now there are two spheres of radius  $r$  and  $r+dr$ . There are two cones with half angles  $\theta$  and  $\theta+d\theta$ . There are two planes at the angles  $\phi$  and  $\phi+d\phi$  measured from  $xz$  plane. All these surfaces enclose a small volume as shown in the Fig. 1.30.



**Fig. 1.30 Differential volume in spherical co-ordinate system**

The differential length in  $r$  direction is  $dr$ . The differential length in  $\phi$  direction is  $r \sin \theta d\phi$ . The differential length in  $\theta$  direction is  $r d\theta$ . Thus,

$$dr = \text{Differential length in } r \text{ direction} \quad \dots (5)$$

$$r d\theta = \text{Differential length in } \theta \text{ direction} \quad \dots (6)$$

$$r \sin \theta d\phi = \text{Differential length in } \phi \text{ direction} \quad \dots (7)$$



Hence the differential vector length in spherical coordinate system is given by,

$$\vec{dl} = dr \vec{a}_r + r d\theta \vec{a}_\theta + r \sin \theta d\phi \vec{a}_\phi \quad \dots (8)$$

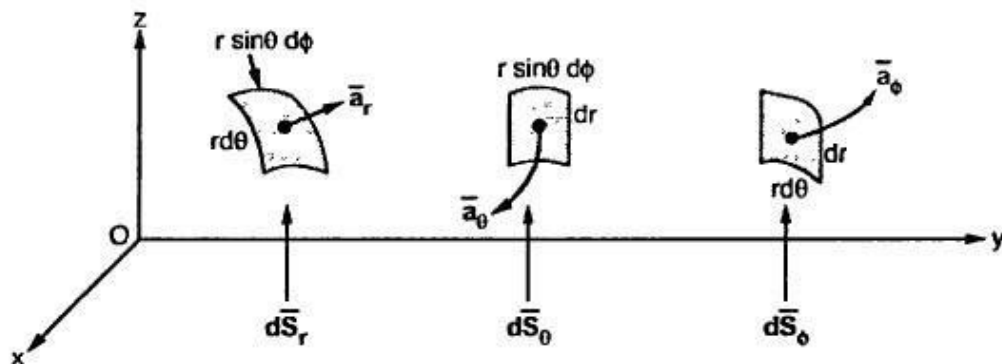
The magnitude of the differential length vector is given by,

$$|\vec{dl}| = \sqrt{(dr)^2 + (r d\theta)^2 + (r \sin \theta d\phi)^2} \quad \dots (9)$$

Hence the differential volume of the differential element formed, in spherical co-ordinate system is given by,

$$dv = r^2 \sin \theta dr d\theta d\phi \quad \dots (10)$$

The differential surface areas in the three directions are shown in the Fig. 1.31.



**Fig. 1.31 Differential surface elements in spherical co-ordinate system**

The vector representation of these differential surface areas are given by,

$$\begin{aligned} d\vec{S}_r &= \text{Differential vector surface area normal to } r \text{ direction} \\ &= r^2 \sin \theta d\theta d\phi \quad \dots (11) \end{aligned}$$

$$\begin{aligned} d\vec{S}_\theta &= \text{Differential vector surface area normal to } \theta \text{ direction} \\ &= r \sin \theta dr d\phi \quad \dots (12) \end{aligned}$$

$$\begin{aligned} d\vec{S}_\phi &= \text{Differential vector surface area normal to } \phi \text{ direction} \\ &= r dr d\theta \quad \dots (13) \end{aligned}$$

## 1.16 Divergence Theorem

It is known that,

$$\nabla \cdot \vec{F} = \lim_{\Delta v \rightarrow 0} \frac{\oint_S \vec{F} \cdot d\vec{S}}{\Delta v} \quad \dots \text{Definition of divergence}$$

From this definition it can be written that,

$$\boxed{\oint_S \vec{F} \cdot d\vec{S} = \int_v (\nabla \cdot \vec{F}) dv} \quad \dots(1)$$

This equation (1) is known as **divergence theorem** or **Gauss-Ostrogradsky theorem**.

The Divergence theorem states that,

The integral of the normal component of any vector field over a closed surface is equal to the integral of the divergence of this vector field throughout the volume enclosed by that closed surface.

The theorem can be applied to any vector field but partial derivatives of that vector field must exist. The divergence theorem as applied to the flux density. Both sides of the divergence theorem give the net charge enclosed by the closed surface i.e. net flux crossing the closed surface.

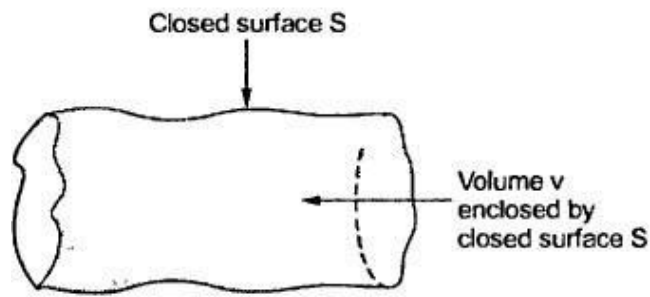


Fig. 1.49

This is advantageous in electromagnetic theory as volume integrals are more easy to evaluate than the surface integrals.

The Fig. 1.49 shows how closed surface S encloses a volume v for which divergence theorem is applicable.

**Key Point:** The divergence theorem as applied with Gauss's law is included in the section 3.12 of chapter 3.

## 1.17 Gradient of a Scalar

Consider that in space let  $W$  be the unique function of  $x$ ,  $y$  and  $z$  co-ordinates in the cartesian system. This is the **scalar function** and denoted as  $W(x, y, z)$ . Consider the vector operator in cartesian system denoted as  $\nabla$  called del. It is defined as,

$$\boxed{\nabla (\text{del}) = \frac{\partial}{\partial x} \vec{a}_x + \frac{\partial}{\partial y} \vec{a}_y + \frac{\partial}{\partial z} \vec{a}_z}$$

The gradient of a scalar  $W$  in various co-ordinate systems are given by,

Sr. No	Co-ordinate system	Grad $W = \nabla W$
1.	Cartesian	$\nabla W = \frac{\partial W}{\partial x} \bar{a}_x + \frac{\partial W}{\partial y} \bar{a}_y + \frac{\partial W}{\partial z} \bar{a}_z$
2.	Cylindrical	$\nabla W = \frac{\partial W}{\partial r} \bar{a}_r + \frac{1}{r} \frac{\partial W}{\partial \phi} \bar{a}_\phi + \frac{\partial W}{\partial z} \bar{a}_z$
3.	Spherical	$\nabla W = \frac{\partial W}{\partial r} \bar{a}_r + \frac{1}{r} \frac{\partial W}{\partial \theta} \bar{a}_\theta + \frac{1}{r \sin \theta} \frac{\partial W}{\partial \phi} \bar{a}_\phi$

Table 1.4

### 1.17.1 Properties of Gradient of a Scalar

The various properties of a gradient of a scalar field  $W$  are,

1. The gradient  $\nabla W$  gives the maximum rate of change of  $W$  per unit distance.
2. The gradient  $\nabla W$  always indicates the direction of the maximum rate of change of  $W$ .
3. The gradient  $\nabla W$  at any point is perpendicular to the constant  $W$  surface, which passes through the point.
4. The directional derivative of  $W$  along the unit vector  $\bar{a}$  is  $\nabla W \cdot \bar{a}$  (dot product), which is projection of  $\nabla W$  in the direction of unit vector  $\bar{a}$ .

If  $U$  is the another scalar function then,

### 1.18 Curl of a Vector

The circulation of a vector field around a closed path is given by curl of a vector. Mathematically it is defined as,

$$\text{Curl of } \bar{F} = \lim_{\Delta S_N \rightarrow 0} \frac{\oint \bar{F} \cdot d\bar{l}}{\Delta S_N} \quad \dots (1)$$

where  $\Delta S_N =$  Area enclosed by the line integral in normal direction

Thus maximum circulation of  $\bar{F}$  per unit area as area tends to zero whose direction is normal to the surface is called curl of  $\bar{F}$ .

Symbolically it is expressed as,

$$\nabla \times \bar{F} = \text{curl of } \bar{F} \quad \dots (2)$$

**Key Point:** Curl indicates the rotational property of vector field. If curl of vector is zero, the vector field is irrotational.

In various co-ordinate systems, the curl of  $\bar{F}$  is given by,

$$\nabla \times \bar{F} = \left[ \frac{\partial F_z}{\partial y} - \frac{\partial F_y}{\partial z} \right] \bar{a}_x + \left[ \frac{\partial F_x}{\partial z} - \frac{\partial F_z}{\partial x} \right] \bar{a}_y + \left[ \frac{\partial F_y}{\partial x} - \frac{\partial F_x}{\partial y} \right] \bar{a}_z$$

i.e. 
$$\nabla \times \bar{F} = \begin{vmatrix} \bar{a}_x & \bar{a}_y & \bar{a}_z \\ \frac{\partial}{\partial x} & \frac{\partial}{\partial y} & \frac{\partial}{\partial z} \\ F_x & F_y & F_z \end{vmatrix} \quad \text{Cartesian} \quad \dots(3)$$

$$\nabla \times \bar{F} = \left[ \frac{1}{r} \frac{\partial F_z}{\partial \phi} - \frac{\partial F_\phi}{\partial z} \right] \bar{a}_r + \left[ \frac{\partial F_r}{\partial z} - \frac{\partial F_z}{\partial r} \right] \bar{a}_\phi + \left[ \frac{1}{r} \frac{\partial(r F_\phi)}{\partial r} - \frac{1}{r} \frac{\partial F_r}{\partial \phi} \right] \bar{a}_z$$

i.e. 
$$\nabla \times \bar{F} = \frac{1}{r} \begin{vmatrix} \bar{a}_r & r \bar{a}_\phi & \bar{a}_z \\ \frac{\partial}{\partial r} & \frac{\partial}{\partial \phi} & \frac{\partial}{\partial z} \\ F_r & F_\phi & F_z \end{vmatrix} \quad \text{Cylindrical} \quad \dots(4)$$

**Key Point:** In  $\frac{\partial(r F_\phi)}{\partial r}$ ,  $r$  cannot be taken outside as differentiation is with respect to  $r$ .

$$\nabla \times \bar{F} = \frac{1}{r \sin \theta} \left[ \frac{\partial F_\phi \sin \theta}{\partial \theta} - \frac{\partial F_\theta}{\partial \phi} \right] \bar{a}_r + \frac{1}{r} \left[ \frac{1}{\sin \theta} \frac{\partial F_r}{\partial \phi} - \frac{\partial(r F_\phi)}{\partial r} \right] \bar{a}_\theta + \frac{1}{r} \left[ \frac{\partial(r F_\theta)}{\partial r} - \frac{\partial F_r}{\partial \theta} \right] \bar{a}_\phi$$

i.e. 
$$\nabla \times \bar{F} = \frac{1}{r^2 \sin \theta} \begin{vmatrix} \bar{a}_r & r \bar{a}_\theta & r \sin \theta \bar{a}_\phi \\ \frac{\partial}{\partial r} & \frac{\partial}{\partial \theta} & \frac{\partial}{\partial \phi} \\ F_r & r F_\theta & r \sin \theta F_\phi \end{vmatrix} \quad \text{Spherical}$$

**Key Point:** The physical significance and concept of curl is discussed in detail in section 7.10 of chapter 7.

### 2.2.1 Statement of Coulomb's Law

The Coulomb's law states that force between the two point charges  $Q_1$  and  $Q_2$ ,

1. Acts along the line joining the two point charges.
2. Is directly proportional to the product ( $Q_1 Q_2$ ) of the two charges.
3. Is inversely proportional to the square of the distance between them.

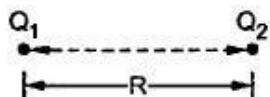


Fig. 2.1

Consider the two point charges  $Q_1$  and  $Q_2$  as shown in the Fig. 2.1, separated by the distance  $R$ . The charge  $Q_1$  exerts a force on  $Q_2$  while  $Q_2$  also exerts a force on  $Q_1$ . The force acts along the line joining  $Q_1$  and  $Q_2$ . The force exerted between them is repulsive if the charges are of same polarity while it is attractive if the charges are of different polarity.

Mathematically the force  $F$  between the charges can be expressed as,

$$F \propto \frac{Q_1 Q_2}{R^2} \quad \dots (1)$$

where  $Q_1 Q_2$  = Product of the two charges

$R$  = Distance between the two charges

The Coulomb's law also states that this force depends on the **medium** in which the point charges are located. The effect of medium is introduced in the equation of force as a constant of proportionality denoted as  $k$ .

$$\therefore F = k \frac{Q_1 Q_2}{R^2} \quad \dots (2)$$

where  $k$  = Constant of proportionality

### 2.2.1.1 Constant of Proportionality ( $k$ )

The constant of proportionality takes into account the effect of medium, in which charges are located. In the International System of Units (SI), the charges  $Q_1$  and  $Q_2$  are expressed in Coulombs (C), the distance  $R$  in metres (m) and the force  $F$  in newtons (N). Then to satisfy Coulomb's law, the constant of proportionality is defined as,

$$k = \frac{1}{4\pi\epsilon} \quad \dots (3)$$

where  $\epsilon$  = Permittivity of the medium in which charges are located

The units of  $\epsilon$  are farads/metre (F/m).

In general  $\epsilon$  is expressed as,

$$\epsilon = \epsilon_0 \epsilon_r \quad \dots (4)$$

where  $\epsilon_0$  = Permittivity of the free space or vacuum

$\epsilon_r$  = Relative permittivity or dielectric constant of the medium with respect to free space

$\epsilon$  = Absolute permittivity

For the **free space** or **vacuum**, the relative permittivity  $\epsilon_r = 1$ , hence

$$\therefore F = \frac{1}{4\pi\epsilon_0} \frac{Q_1 Q_2}{R^2} \quad \dots (5)$$

The value of permittivity of free space  $\epsilon_0$  is,

$$\epsilon_0 = \frac{1}{36\pi} \times 10^{-9} = 8.854 \times 10^{-12} \text{ F/m} \quad \dots (6)$$

$$\therefore k = \frac{1}{4\pi\epsilon_0} = \frac{1}{4\pi \times 8.854 \times 10^{-12}} = 8.98 \times 10^9 = 9 \times 10^9 \text{ m/F} \quad \dots (7)$$

Hence the Coulomb's law can be expressed as,

$$F = \frac{Q_1 Q_2}{4\pi\epsilon_0 R^2} \quad \dots (8)$$

This is the force between the two point charges located in **free space** or **vacuum**.

**Key Point:** As  $Q$  is measured in Coulomb,  $R$  in metre and  $F$  in newton, the units of  $\epsilon_0$  are,

$$\text{Unit of } \epsilon_0 = \frac{(C)(C)}{(N)(m^2)} = \frac{C^2}{N \cdot m^2} = \frac{C^2}{N \cdot m} \times \frac{1}{m}$$

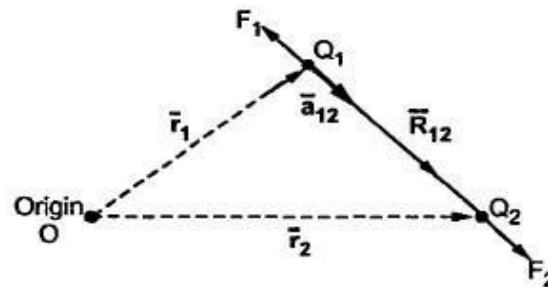
But  $\frac{C^2}{N \cdot m} = \text{Farad}$  which is practical unit of capacitance

$$\therefore \text{Unit of } \epsilon_0 = \text{F/m}$$

## 2.2.2 Vector Form of Coulomb's Law

The force exerted between the two point charges has a fixed direction which is a straight line joining the two charges. Hence the force exerted between the two charges can be expressed in a vector form.

Consider the two point charges  $Q_1$  and  $Q_2$  located at the points having position vectors  $\vec{r}_1$  and  $\vec{r}_2$  as shown in the Fig. 2.2.



**Fig. 2.2 Vector form of Coulomb's law**

Then the force exerted by  $Q_1$  on  $Q_2$  acts along the direction  $\vec{R}_{12}$  where  $\vec{a}_{12}$  is unit vector along  $\vec{R}_{12}$ . Hence the force in the vector form can be expressed as,

$$\vec{F}_2 = \frac{Q_1 Q_2}{4\pi\epsilon_0 R_{12}^2} \vec{a}_{12} \quad \dots (9)$$

where  $\vec{a}_{12} = \text{Unit vector along } \vec{R}_{12} = \frac{\text{Vector}}{\text{Magnitude of vector}}$

$$\therefore \vec{a}_{12} = \frac{\vec{R}_{12}}{|\vec{R}_{12}|} = \frac{\vec{r}_2 - \vec{r}_1}{|\vec{r}_2 - \vec{r}_1|} = \frac{\vec{r}_2 - \vec{r}_1}{|\vec{r}_2 - \vec{r}_1|} \quad \dots (10)$$

where  $|\vec{R}_{12}| = R = \text{distance between the two charges}$

The following observations are important :

1. As shown in the Fig. 2.3, the force  $F_1$  is the force exerted on  $Q_1$  due to  $Q_2$ . It can be expressed as,

$$\vec{F}_1 = \frac{Q_1 Q_2}{4\pi\epsilon_0 R_{21}^2} \vec{a}_{21} = \frac{Q_1 Q_2}{4\pi\epsilon_0 R_{21}^2} \times \frac{\vec{r}_1 - \vec{r}_2}{|\vec{r}_1 - \vec{r}_2|} \quad \dots (11)$$

But  $\vec{r}_1 - \vec{r}_2 = -[\vec{r}_2 - \vec{r}_1]$

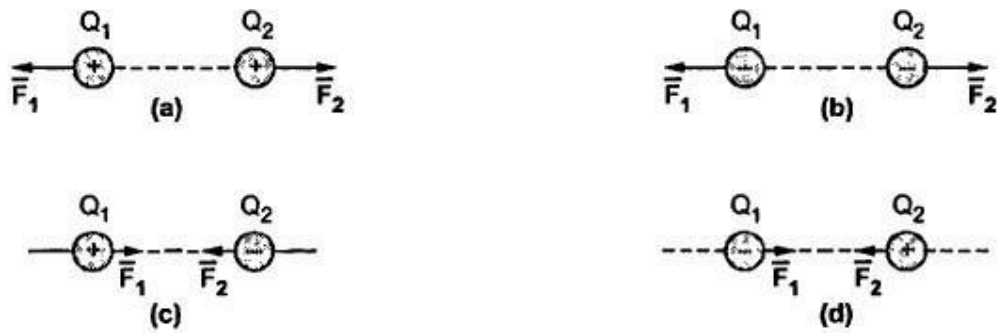
$$\therefore \vec{a}_{21} = -\vec{a}_{12}$$

Hence substituting in (11),

$$\vec{F}_1 = \frac{Q_1 Q_2}{4\pi\epsilon_0 R_{21}^2} (-\vec{a}_{21}) = -\vec{F}_2 \quad \dots (12)$$

Hence force exerted by the two charges on each other is equal but opposite in direction.

2. The like charges repel each other while the unlike charges attract each other. This is shown in the Fig. 2.3. These are experiment conclusions though not reflected in the mathematical expression.



**Fig. 2.3**

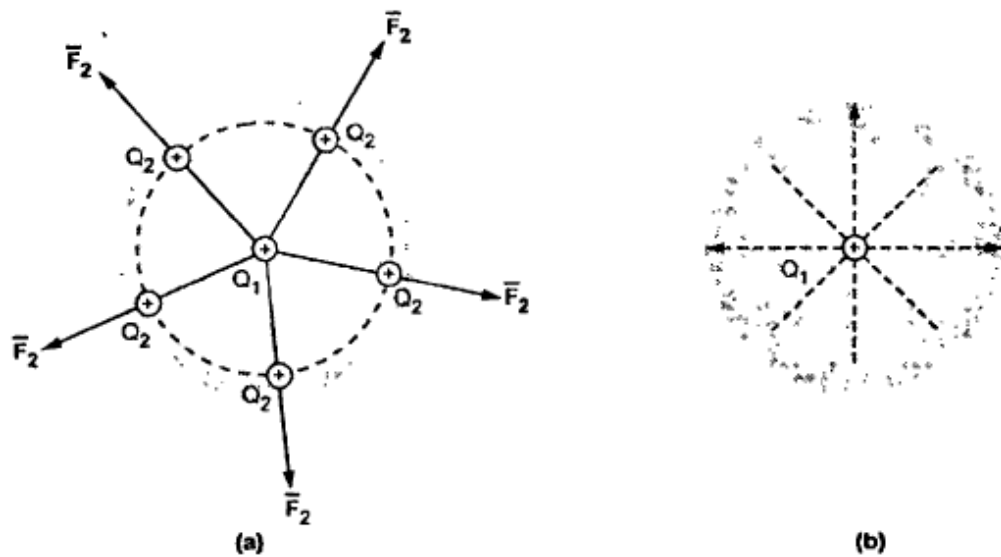
3. It is necessary that the two charges are the point charges and stationary in nature.
4. The two point charges may be positive or negative. Hence their signs must be considered while using equation (9) to calculate the force exerted.
5. The Coulomb's law is linear which shows that if any one charge is increased 'n' times then the force exerted also increase by n times.

$$\therefore \quad \bar{F}_2 = -\bar{F}_1 \quad \text{then} \quad n\bar{F}_2 = -n\bar{F}_1$$

where  $n = \text{Scalar}$

### 2.3 Electric Field Intensity

Consider a point charge  $Q_1$  as shown in Fig. 2.7 (a).



**Fig. 2.7 Electric field**



If any other similar charge  $Q_2$  is brought near it,  $Q_2$  experiences a force. Infact if  $Q_2$  is moved around  $Q_1$ , still  $Q_2$  experiences a force as shown in the Fig. 2.7 (a).

Thus there exists a region around a charge in which it exerts a force on any other charge. This region where a particular charge exerts a force on any other charge located in that region is called **electric field** of that charge. The electric field of  $Q_1$  is shown in the Fig. 2.7 (b).

The force experienced by the charge  $Q_2$  due to  $Q_1$  is given by Coulomb's law as,

$$\vec{F}_2 = \frac{Q_1 Q_2}{4\pi\epsilon_0 R_{12}^2} \vec{a}_{12}$$

Thus force per unit charge can be written as,

$$\frac{\vec{F}_2}{Q_2} = \frac{Q_1}{4\pi\epsilon_0 R_{12}^2} \vec{a}_{12} \quad \dots (1)$$

This force exerted per unit charge is called **electric field intensity** or **electric field strength**. It is a **vector quantity** and is directed along a segment from the charge  $Q_1$  to the position of any other charge. It is denoted as  $\vec{E}$ .

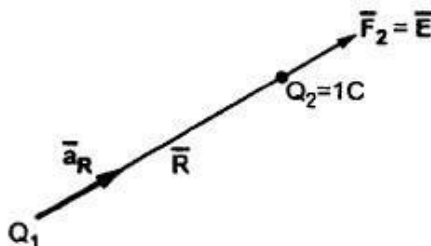
$$\therefore \quad \boxed{\vec{E} = \frac{Q_1}{4\pi\epsilon_0 R_{1p}^2} \vec{a}_{1p}} \quad \dots (2)$$

where  $p$  = Position of any other charge around  $Q_1$

The equation (2) is the electric field intensity due to a single point charge  $Q_1$  in a free space or vacuum.

Another definition of electric field intensity is the force experienced by a unit positive test charge i.e.  $Q_2 = 1C$ .

Consider a charge  $Q_1$  as shown in the Fig. 2.8. The unit positive charge  $Q_2 = 1C$  is placed at a distance  $R$  from  $Q_1$ . Then the force acting on  $Q_2$  due to  $Q_1$  is along the unit vector  $\vec{a}_R$ . As the charge  $Q_2$  is unit charge, the force exerted on  $Q_2$  is nothing but electric field intensity  $\vec{E}$  of  $Q_1$  at the point where unit charge is placed.



**Fig. 2.8 Concept of electric field intensity**

$$\therefore \quad \boxed{\bar{E} = \frac{Q_1}{4\pi\epsilon_0 R^2} \bar{a}_R} \quad \dots (3)$$

If a charge  $Q_1$  is located at the center of the spherical coordinate system then unit vector  $\bar{a}_R$  in the equation (3) becomes the radial unit vector  $\bar{a}_r$ , coming radially outwards from  $Q_1$ . And the distance  $R$  is the radius of the sphere  $r$ .

$$\therefore \quad \bar{E} = \frac{Q_1}{4\pi\epsilon_0 r^2} \bar{a}_r, \text{ in spherical system} \quad \dots (4)$$

## 2.4 Types of Charge Distributions

Uptill now the forces and electric fields due to only point charges are considered. In addition to the **point charges**, there is possibility of continuous charge distributions along a line, on a surface or in a volume. Thus there are four types of charge distributions which are,

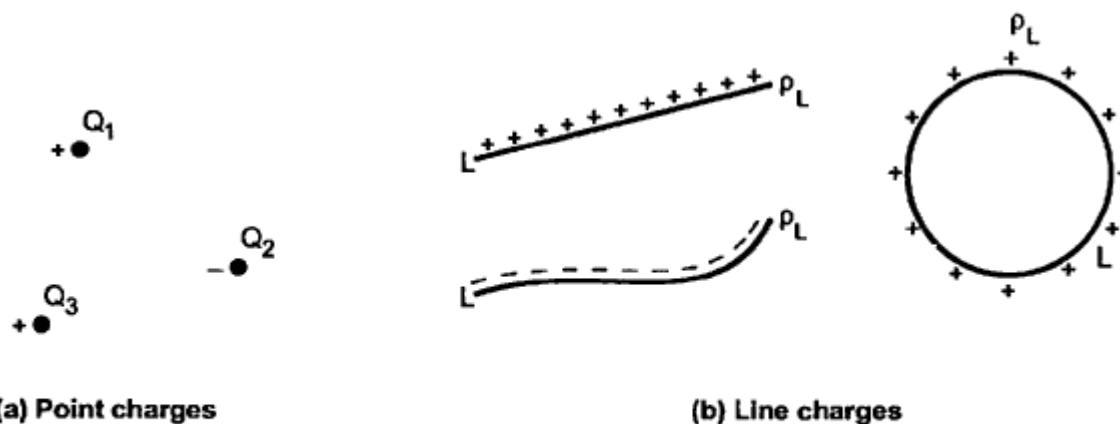
1. Point charge
2. Line charge
3. Surface charge
4. Volume charge

### 2.4.1 Point Charge

It is seen that if the dimensions of a surface carrying charge are very very small compared to region surrounding it then the surface can be treated to be a point. The corresponding charge is called **point charge**. The point charge has a position but not the dimensions. This is shown in the Fig. 2.14 (a). The point charge can be positive or negative.

### 2.4.2 Line Charge

It is possible that the charge may be spreaded all along a line, which may be finite or infinite. Such a charge uniformly distributed along a line is called a **line charge**. This is shown in the Fig. 2.14 (b).



**Fig. 2.14 Charge distributions**

The charge density of the line charge is denoted as  $\rho_L$  and defined as charge per unit length.

$$\therefore \rho_L = \frac{\text{Total charge in coulomb}}{\text{Total length in metres}} \text{ (C/m)}$$

Thus  $\rho_L$  is measured in C/m. The  $\rho_L$  is constant all along the length L of the line carrying the charge.

#### 2.4.2.1 Method of Finding Q from $\rho_L$

In many cases,  $\rho_L$  is given to be the function of coordinates of the line i.e.  $\rho_L = 3x$  or  $\rho_L = 4y^2$  etc. In such a case it is necessary to find the total charge Q by considering differential length  $dl$  of the line. Then by integrating the charge  $dQ$  on  $dl$ , for the entire length, total charge Q is to be obtained. Such an integral is called line integral.

Mathematically,  $dQ = \rho_L dl = \text{charge on differential length } dl$

$$\therefore Q = \int_L dQ = \int_L \rho_L dl \quad \dots (1)$$

If the line of length L is a closed path as shown in the Fig. 2.14 (b) then integral is called closed contour integral and denoted as,

$$Q = \oint_L \rho_L dl \quad \dots (2)$$

A sharp beam in a cathode ray tube or a charged circular loop of conductor are the examples of line charge. The charge distributed may be positive or negative along a line.

➔ **Example 2.6 :** A charge is distributed on x axis of cartesian system having a line charge density of  $3x^2 \mu\text{C/m}$ . Find the total charge over the length of 10 m.

**Solution :** Given  $\rho_L = 3x^2 \mu\text{C/m}$  and  $L = 10$  m along x axis.

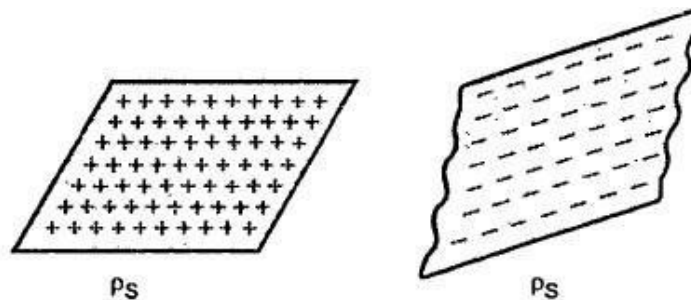
The differential length be  $dl = dx$  in x direction and corresponding charge is  $dQ = \rho_L dl = \rho_L dx$ .

$$\begin{aligned} \therefore Q &= \int_L \rho_L dl = \int_0^{10} 3x^2 dx = \left[ \frac{3x^3}{3} \right]_0^{10} \\ &= 1000 \mu\text{C} = 1 \text{ mC} \end{aligned}$$

### 2.4.3 Surface Charge

If the charge is distributed uniformly over a two dimensional surface then it is called a **surface charge** or a **sheet of charge**. The surface charge is shown in the Fig. 2.15.

The two dimensional surface has area in square metres. Then the surface charge density is denoted as  $\rho_S$  and defined as the charge per unit surface area.



**Fig. 2.15 Surface charge distributions**

$$\therefore \rho_S = \frac{\text{Total charge in coulomb}}{\text{Total area in square metres}} \text{ (C/m}^2\text{)}$$

Thus  $\rho_S$  is expressed in  $\text{C/m}^2$ . The  $\rho_S$  is constant over the surface carrying the charge.

#### 2.4.3.1 Method of Finding Q from $\rho_S$

In case of surface charge distribution, it is necessary to find the total charge Q by considering elementary surface area  $dS$ . The charge  $dQ$  on this differential area is given by  $\rho_S dS$ . Then integrating this  $dQ$  over the given surface, the total charge Q is to be obtained. Such an integral is called a **surface integral** and mathematically given by,

$$Q = \int_S dQ = \int_S \rho_S dS \quad \dots (3)$$

The plate of a charged parallel plate capacitor is an example of surface charge distribution. If the dimensions of the sheet of charge are very large compared to the distance at which the effects of charge are to be considered then the distribution is called infinite sheet of charge.

### 2.4.4 Volume Charge

If the charge distributed uniformly in a volume then it is called volume charge. The volume charge is shown in the Fig. 2.16.

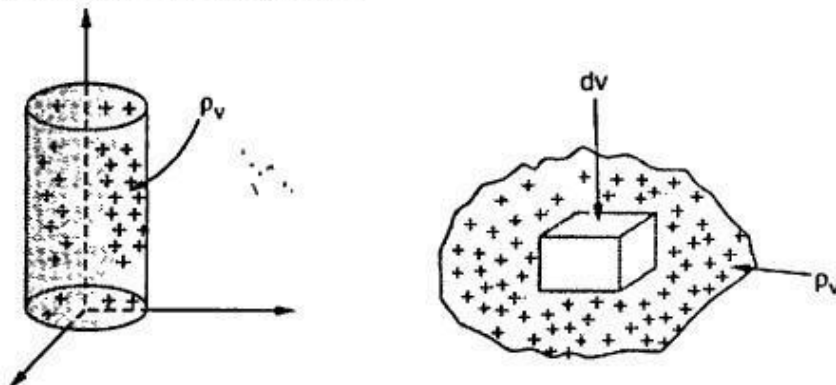


Fig. 2.16 Volume charge distribution

The volume charge density is denoted as  $\rho_v$  and defined as the charge per unit volume.

$$\rho_v = \frac{\text{Total charge in coulomb}}{\text{Total volume in cubic metres}} \left( \frac{\text{C}}{\text{m}^3} \right)$$

Thus  $\rho_v$  is expressed in  $\text{C}/\text{m}^3$ .

#### 2.4.4.1 Method of Finding Q from $\rho_v$

In case of volume charge distribution, consider the differential volume  $dv$  as shown in the Fig. 2.16. Then the charge  $dQ$  possessed by the differential volume is  $\rho_v dv$ . Then the total charge within the finite given volume is to be obtained by integrating the  $dQ$  throughout that volume. Such an integral is called volume integral. Mathematically it is given by,

$$Q = \int_{\text{vol}} \rho_v dv \quad \dots (4)$$

## 2.5 Electric Field Intensity due to Various Charge Distributions

It is known that the electric field intensity due to a point charge  $Q$  is given by,

$$\vec{E} = \frac{Q}{4\pi\epsilon_0 R^2} \vec{a}_R$$

Let us consider various charge distributions.

### 2.5.1 $\vec{E}$ due to Line Charge

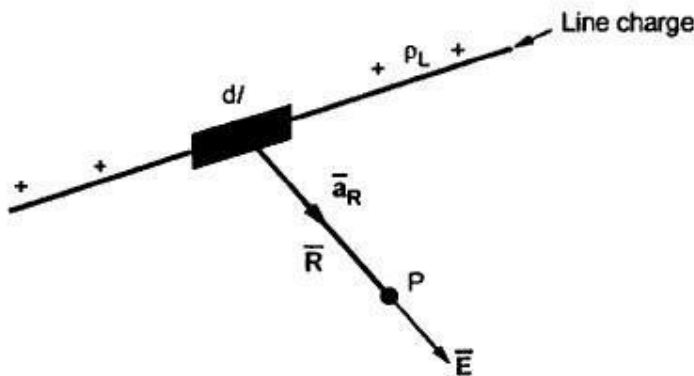


Fig. 2.17

Consider a line charge distribution having a charge density  $\rho_L$  as shown in the Fig. 2.17.

The charge  $dQ$  on the differential length  $dl$  is,

$$dQ = \rho_L dl$$

Hence the differential electric field  $d\vec{E}$  at point  $P$  due to  $dQ$  is given by,

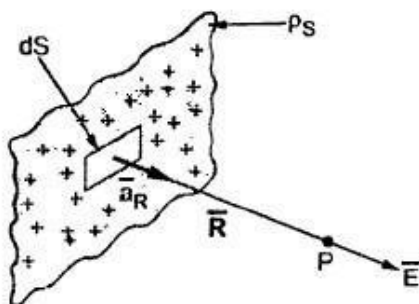
$$d\vec{E} = \frac{dQ}{4\pi\epsilon_0 R^2} \vec{a}_R = \frac{\rho_L dl}{4\pi\epsilon_0 R^2} \vec{a}_R \quad \dots (1)$$

Hence the total  $\vec{E}$  at a point  $P$  due to line charge can be obtained by integrating  $d\vec{E}$  over the length of the charge.

$$\therefore \vec{E} = \int_L \frac{\rho_L dl}{4\pi\epsilon_0 R^2} \vec{a}_R \quad \dots (2)$$

The  $\vec{a}_R$  and  $dl$  is to be obtained depending upon the co-ordinate system used.

### 2.5.2 $\vec{E}$ due to Surface Charge



Consider a surface charge distribution having a charge density  $\rho_S$  as shown in the Fig. 2.18.

The charge  $dQ$  on the differential surface area  $dS$  is,

$$dQ = \rho_S dS$$

Hence the differential electric field  $d\vec{E}$  at a point P due to dQ is given by,

$$d\vec{E} = \frac{dQ}{4\pi\epsilon_0 R^2} \vec{a}_R = \frac{\rho_S dS}{4\pi\epsilon_0 R^2} \vec{a}_R \quad \dots (3)$$

Hence the total  $\vec{E}$  at a point P is to be obtained by integrating  $d\vec{E}$  over the surface area on which charge is distributed. Note that this will be a double integration.

$$\therefore \vec{E} = \int_S \frac{\rho_S dS}{4\pi\epsilon_0 R^2} \vec{a}_R \quad \dots (4)$$

The  $\vec{a}_R$  and  $dS$  to be obtained according to the position of the sheet of charge and the coordinate system used.

### 2.5.3 $\vec{E}$ due to Volume Charge

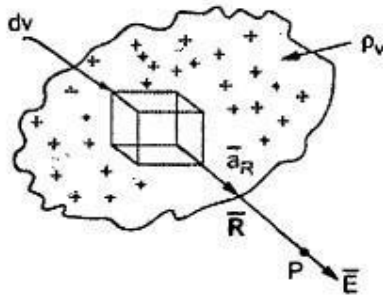


Fig. 2.19

Consider a volume charge distribution having a charge density  $\rho_v$  as shown in the Fig. 2.19.

The charge dQ on the differential volume  $dv$  is,

$$dQ = \rho_v dv$$

Hence the differential electric field  $d\vec{E}$  at a point P due to dQ is given by,

$$d\vec{E} = \frac{dQ}{4\pi\epsilon_0 R^2} \vec{a}_R = \frac{\rho_v dv}{4\pi\epsilon_0 R^2} \vec{a}_R \quad \dots (5)$$

Hence the total  $\vec{E}$  at a point P is to be obtained by integrating  $d\vec{E}$  over the volume in which charge is accumulated. Note that this integration will be a triple integration.

$$\therefore \vec{E} = \int_{\text{Vol}} \frac{\rho_v dv}{4\pi\epsilon_0 R^2} \vec{a}_R \quad \dots (6)$$

The  $\vec{a}_R$  and  $dv$  must be obtained according to the co-ordinate system used.

Thus if there are all possible types of charge distributions, then the total  $\vec{E}$  at a point is the vector sum of individual electric field intensities produced by each of the charges at a point under consideration.

$$\therefore \vec{E}_{\text{total}} = \vec{E}_p + \vec{E}_l + \vec{E}_s + \vec{E}_v \quad \dots (7)$$

where  $\vec{E}_p$ ,  $\vec{E}_l$ ,  $\vec{E}_s$  and  $\vec{E}_v$  are the field intensities due to point, line, surface and volume charge distributions respectively.

Let us discuss and learn the method of obtaining electric field intensities under widely varying charge distributions.

## 2.6 Electric Field due to Infinite Line Charge

Consider an infinitely long straight line carrying uniform line charge having density  $\rho_L$  C/m. Let this line lies along z-axis from  $-\infty$  to  $\infty$  and hence called infinite line charge. Let point P is on y-axis at which electric field intensity is to be determined. The distance of point P from the origin is 'r' as shown in the Fig. 2.20.

Consider a small differential length  $dl$  carrying a charge  $dQ$ , along the line as shown in the Fig. 2.20. It is along z axis hence  $dl = dz$ .

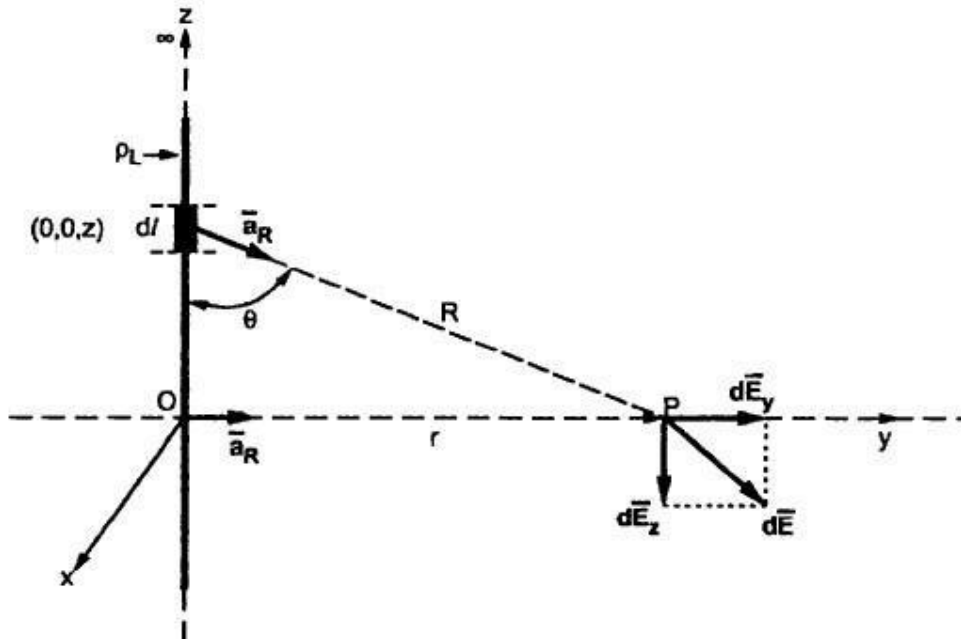


Fig. 2.20 Field due to infinite line charge

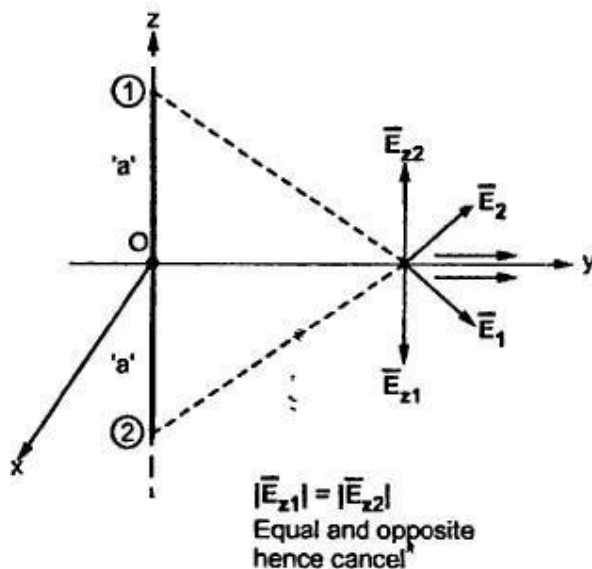


Fig. 2.21

$$\therefore dQ = \rho_L dl = \rho_L dz \quad \dots (1)$$

The co-ordinates of  $dQ$  are  $(0, 0, z)$  while the co-ordinates of point P are  $(0, r, 0)$ . Hence the distance vector  $\vec{R}$  can be written as,

$$\vec{R} = \vec{r}_P - \vec{r}_{dl} = [r\vec{a}_y - z\vec{a}_z]$$

$$\therefore |\vec{R}| = \sqrt{r^2 + z^2}$$

$$\therefore \vec{a}_R = \frac{\vec{R}}{|\vec{R}|} = \frac{r\vec{a}_y - z\vec{a}_z}{\sqrt{r^2 + z^2}} \quad \dots (2)$$

$$\therefore d\vec{E} = \frac{dQ}{4\pi\epsilon_0 R^2} \vec{a}_R$$

$$= \frac{\rho_L dz}{4\pi\epsilon_0 (\sqrt{r^2 + z^2})^2} \left[ \frac{r\vec{a}_y - z\vec{a}_z}{\sqrt{r^2 + z^2}} \right] \quad \dots (3)$$



**Note :** For every charge on positive z-axis there is equal charge present on negative z-axis. Hence the z component of electric field intensities produced by such charges at point P will cancel each other. Hence effectively there will not be any z component of  $\bar{E}$  at P. This is shown in the Fig. 2.21.

Hence the equation of  $d\bar{E}$  can be written by eliminating  $\bar{a}_z$  component,

$$\therefore d\bar{E} = \frac{\rho_L dz}{4\pi\epsilon_0 (\sqrt{r^2+z^2})^2} \frac{r\bar{a}_y}{\sqrt{r^2+z^2}} \quad \dots (4)$$

Now by integrating  $d\bar{E}$  over the z-axis from  $-\infty$  to  $\infty$  we can obtain total  $\bar{E}$  at point P.

$$\therefore \bar{E} = \int_{-\infty}^{\infty} \frac{\rho_L}{4\pi\epsilon_0 (r^2+z^2)^{3/2}} r dz \bar{a}_y$$

**Note :** For such an integration, use the substitution

$$z = r \tan \theta \quad \text{i.e.} \quad r = \frac{z}{\tan \theta}$$

$$\therefore dz = r \sec^2 \theta d\theta$$

Here r is not the variable of integration.

$$\text{For } z = -\infty, \quad \theta = \tan^{-1}(-\infty) = -\pi/2 = -90^\circ$$

$$\text{For } z = +\infty, \quad \theta = \tan^{-1}(\infty) = \pi/2 = +90^\circ$$

} Changing the limits

$$\begin{aligned} \therefore \bar{E} &= \int_{\theta=-\pi/2}^{\pi/2} \frac{\rho_L}{4\pi\epsilon_0 [r^2+r^2 \tan^2 \theta]^{3/2}} r \times r \sec^2 \theta d\theta \bar{a}_y \\ &= \frac{\rho_L}{4\pi\epsilon_0} \int_{-\pi/2}^{\pi/2} \frac{r^2 \sec^2 \theta d\theta}{r^3 [1+\tan^2 \theta]^{3/2}} \bar{a}_y \end{aligned}$$

$$\text{But } 1+\tan^2 \theta = \sec^2 \theta$$

$$\begin{aligned} \therefore \bar{E} &= \frac{\rho_L}{4\pi\epsilon_0} \int_{-\pi/2}^{\pi/2} \frac{\sec^2 \theta d\theta}{r \sec^3 \theta} \bar{a}_y \\ &= \frac{\rho_L}{4\pi\epsilon_0 r} \int_{-\pi/2}^{\pi/2} \cos \theta d\theta \bar{a}_y \quad \dots \sec \theta = \frac{1}{\cos \theta} \\ &= \frac{\rho_L}{4\pi\epsilon_0 r} [\sin \theta]_{-\pi/2}^{\pi/2} \bar{a}_y = \frac{\rho_L}{4\pi\epsilon_0 r} \left[ \sin \frac{\pi}{2} - \sin \left( \frac{-\pi}{2} \right) \right] \bar{a}_y \\ &= \frac{\rho_L}{4\pi\epsilon_0 r} [1 - (-1)] \bar{a}_y = \frac{\rho_L}{4\pi\epsilon_0 r} \times 2 \bar{a}_y \end{aligned}$$

$$\therefore \boxed{\bar{E} = \frac{\rho_L}{2\pi\epsilon_0 r} \bar{a}_y \text{ V/m}} \quad \dots (5)$$

The result of equation (5) which is specifically in cartesian system can be generalized. The  $\bar{a}_y$  is unit vector along the distance  $r$  which is perpendicular distance of point P from the line charge. Thus in general  $\bar{a}_y = \bar{a}_r$ .

Hence the result of  $\bar{E}$  can be expressed as,

$$\bar{E} = \frac{\rho_l}{2\pi\epsilon_0 r} \bar{a}_r \text{ V/m} \quad \dots (6)$$

where  $r$  = Perpendicular distance of point P from the line charge

$\bar{a}_r$  = Unit vector in the direction of the perpendicular distance of point P from the line charge

## 2.7 Electric Field due to Charged Circular Ring

Consider a charged circular ring of radius  $r$  placed in  $xy$  plane with centre at origin, carrying a charge uniformly along its circumference. The charge density is  $\rho_L$  C/m.

The point P is at a perpendicular distance 'z' from the ring as shown in the Fig. 2.23.

Consider a small differential length  $dl$  on this ring. The charge on it is  $dQ$ .

$$\therefore dQ = \rho_L dl$$

$$\therefore d\bar{E} = \frac{\rho_L dl}{4\pi\epsilon_0 R^2} \bar{a}_R \quad \dots (1)$$

where  $R$  = Distance of point P from  $dl$ .

Consider the cylindrical co-ordinate system. For  $dl$  we are moving in  $\phi$  direction where  $dl = r d\phi$ .

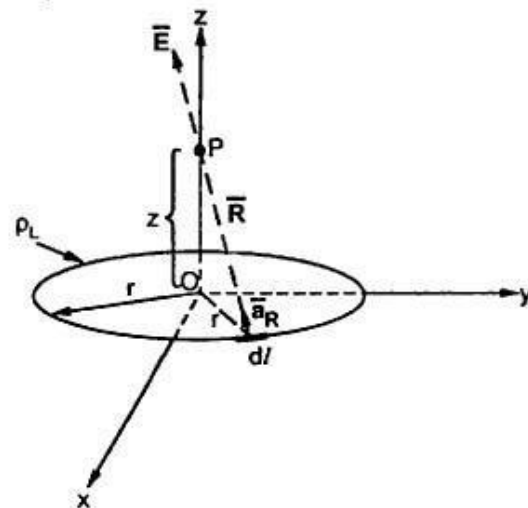


Fig. 2.23

$$\therefore dl = r d\phi \quad \dots (2)$$

$$\text{Now} \quad R^2 = r^2 + z^2$$

... from Fig. 2.23

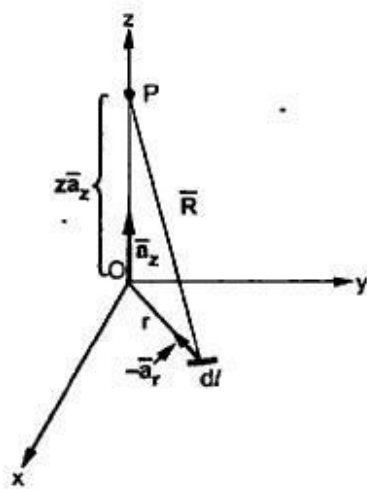


Fig. 2.23(a)

While  $\vec{R}$  can be obtained from its two components, in cylindrical system as shown in the Fig. 2.23(a). The two components are,

1) Distance  $r$  in the direction of  $-\vec{a}_r$ , radially inwards i.e.  $-r\vec{a}_r$ .

2) Distance  $z$  in the direction of  $\vec{a}_z$  i.e.  $z\vec{a}_z$

$$\therefore \vec{R} = -r\vec{a}_r + z\vec{a}_z \quad \dots (3)$$

**Key Point:** This method can be used conveniently to obtain  $\vec{R}$  by identifying its components in the direction of unit vectors in the co-ordinate system considered.

$$\therefore |\vec{R}| = \sqrt{(-r)^2 + (z)^2} = \sqrt{r^2 + z^2} \quad \dots (4)$$

$$\therefore \vec{a}_R = \frac{\vec{R}}{|\vec{R}|} = \frac{-r\vec{a}_r + z\vec{a}_z}{\sqrt{r^2 + z^2}} \quad \dots (5)$$

$$\therefore d\vec{E} = \frac{\rho_L dl}{4\pi\epsilon_0 (\sqrt{r^2 + z^2})^2} \times \frac{-r\vec{a}_r + z\vec{a}_z}{\sqrt{r^2 + z^2}}$$

$$\therefore d\vec{E} = \frac{\rho_L (r d\phi)}{4\pi\epsilon_0 (r^2 + z^2)^{3/2}} [-r\vec{a}_r + z\vec{a}_z] \quad \dots (6)$$

**Note :** The radial components of  $\vec{E}$  at point P will be symmetrically placed in the plane parallel to xy plane and are going to cancel each other. This is shown in the Fig. 2.23 (b). Hence neglecting  $\vec{a}_r$  component from  $d\vec{E}$  we get,

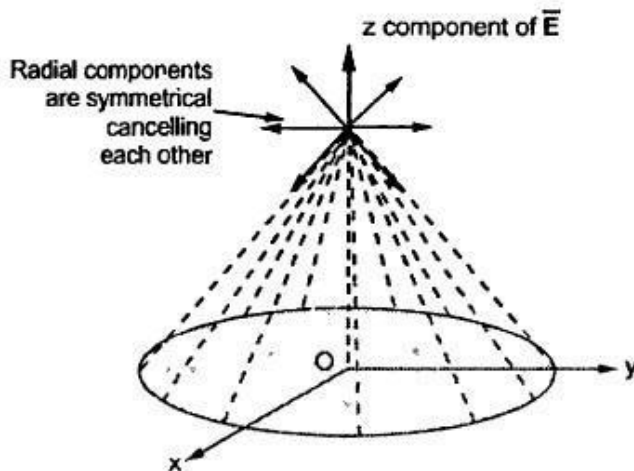


Fig. 2.23 (b)

where  $r$  = Radius of the ring

$$d\vec{E} = \frac{\rho_L (r d\phi)}{4\pi\epsilon_0 (r^2 + z^2)^{3/2}} z\vec{a}_z \quad \dots (7)$$

$$\therefore \vec{E} = \int_{\phi=0}^{2\pi} \frac{\rho_L r d\phi}{4\pi\epsilon_0 (r^2 + z^2)^{3/2}} z\vec{a}_z$$

$$= \frac{\rho_L r}{4\pi\epsilon_0 (r^2 + z^2)^{3/2}} z\vec{a}_z [\phi]_0^{2\pi}$$

... Integration w.r.t.  $\phi$

$$\therefore \vec{E} = \frac{\rho_L r z}{2\epsilon_0 (r^2 + z^2)^{3/2}} \vec{a}_z \quad \dots (8)$$

$z$  = Perpendicular distance of point P from the ring along  
the axis of the ring

This is the electric field at a point P (0, 0, z) due to the circular ring of radius r placed in xy plane.

### 3.8 Applications of Gauss's Law

The Gauss's law is in fact the alternative statement of Coulomb's law. The Gauss's law can be used to find  $\vec{E}$  or  $\vec{D}$  for symmetrical charge distributions, such as point charge, an infinite line charge, an infinite sheet of charge and a spherical distribution of charge. The Gauss's law is also used to find the charge enclosed or the flux passing through the closed surface. Note that whether the charge distribution is symmetrical or not, Gauss's law holds for any closed surface but can be easily applied to the symmetrical distributions. But the Gauss's law cannot be used to find  $\vec{E}$  or  $\vec{D}$  if the charge distribution is not symmetric.

While selecting the closed Gaussian surface to apply the Gauss's law, following conditions must be satisfied,

1.  $\vec{D}$  is every where either normal or tangential to the closed surface i.e.  $\theta = \frac{\pi}{2}$  or  $\pi$ . So that  $\vec{D} \cdot d\vec{S}$  becomes  $DdS$  or zero respectively.

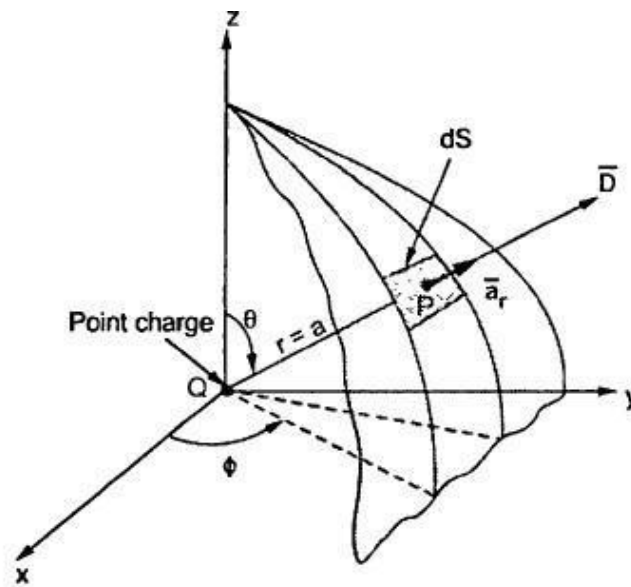
2.  $\vec{D}$  is constant over the portion of the closed surface for which  $\vec{D} \cdot d\vec{S}$  is not zero.

Let us apply these ideas to the various charge distributions.

#### 3.8.1 Point Charge

Let a point charge Q is located at the origin.

To determine  $\vec{D}$  and to apply Gauss's law, consider a spherical surface around Q, with centre as origin. This spherical surface is Gaussian surface and it satisfies required condition. The  $\vec{D}$  is always directed radially outwards along  $\vec{a}_r$ , which is normal to the spherical surface at any point P on the surface. This is shown in the Fig. 3.10.



**Fig. 3.10 Proof of Gauss's law**

Consider a differential surface area  $dS$  as shown. The direction normal to the surface  $dS$  is  $\bar{a}_r$ , considering **spherical co-ordinate system**. The radius of the sphere is  $r = a$ .

The direction of  $\bar{D}$  is along  $\bar{a}_r$ , which is normal to  $dS$  at any point  $P$ .

In spherical co-ordinate system, the  $dS$  normal to radial direction  $\bar{a}_r$  is,

$$dS = r^2 \sin\theta \, d\theta \, d\phi = a^2 \sin\theta \, d\theta \, d\phi \quad (\text{as } r = a)$$

$$\therefore d\bar{S} = dS \bar{a}_n = a^2 \sin\theta \, d\theta \, d\phi \bar{a}_r \quad \dots (1)$$

Now  $\bar{D}$  due to the point charge is given by,

$$\bar{D} = \frac{Q}{4\pi r^2} \bar{a}_r = \frac{Q}{4\pi a^2} \bar{a}_r \quad (\text{as } r = a) \quad \dots (2)$$

$$\therefore \bar{D} \cdot d\bar{S} = |\bar{D}| |d\bar{S}| \cos\theta'$$

Note that  $\theta'$  is the angle between  $\bar{D}$  and  $d\bar{S}$ .

$$\text{where } |\bar{D}| = \frac{Q}{4\pi a^2}, \quad |d\bar{S}| = a^2 \sin\theta \, d\theta \, d\phi, \quad \theta' = 0^\circ$$

The normal to  $d\bar{S}$  is  $\bar{a}_r$ , while  $\bar{D}$  also acts along  $\bar{a}_r$ , hence angle between  $d\bar{S}$  and  $\bar{D}$  i.e.  $\theta' = 0^\circ$ .

$$\begin{aligned} \therefore \bar{D} \cdot d\bar{S} &= \frac{Q}{4\pi a^2} a^2 \sin\theta \, d\theta \, d\phi \cos 0^\circ \\ &= \frac{Q}{4\pi} \sin\theta \, d\theta \, d\phi \quad \dots (3) \end{aligned}$$

Alternatively to avoid the confusion between the symbol  $\theta$  we can write,

$$\begin{aligned}\therefore \quad \bar{D} \cdot d\bar{S} &= \frac{Q}{4\pi a^2} \bar{a}_r \cdot a^2 \sin\theta \, d\theta \, d\phi \bar{a}_r \\ &= \frac{Q}{4\pi} \sin\theta \, d\theta \, d\phi [\bar{a}_r \cdot \bar{a}_r]\end{aligned}$$

But  $\bar{a}_r \cdot \bar{a}_r = 1$

$$\therefore \quad \bar{D} \cdot d\bar{S} = \frac{Q}{4\pi} \sin\theta \, d\theta \, d\phi$$

$$\begin{aligned}\therefore \quad \psi &= \oint_S \bar{D} \cdot d\bar{S} = \int_{\phi=0}^{2\pi} \int_{\theta=0}^{\pi} \frac{Q}{4\pi} \sin\theta \, d\theta \, d\phi \\ &= \frac{Q}{4\pi} [-\cos\theta]_0^{\pi} [\phi]_0^{2\pi} = \frac{Q}{4\pi} [ -(-1) - (-1) ] [2\pi]\end{aligned}$$

$$\therefore \quad \psi = Q \quad \dots \text{ Gauss's law is proved}$$

This proves the Gauss's law that Q coulombs of flux crosses the surface if Q coulombs of charge is enclosed by that surface.

### 3.8.1.1 Use of Gauss's Law to Obtain $\bar{D}$ and $\bar{E}$

Alternatively Gauss's law can be used to obtain  $\bar{D}$  and  $\bar{E}$ . Let us see how ?

From Gauss's law,

$$Q = \oint_S \bar{D} \cdot d\bar{S}$$

For a sphere of radius  $r$ , the flux density  $\bar{D}$  is in radial direction  $\bar{a}_r$  always. Let  $|\bar{D}| = D_r$ .

$$\therefore \quad \bar{D} = D_r \bar{a}_r$$

Let the Gaussian surface is a sphere of radius  $r$  enclosing charge  $Q$ .

While for the Gaussian surface i.e. sphere of radius  $r$ ,  $d\bar{S}$  normal to  $\bar{a}_r$  is,

$$d\bar{S} = r^2 \sin \theta d\theta d\phi \bar{a}_r$$

$$\therefore \bar{D} \cdot d\bar{S} = D_r r^2 \sin \theta d\theta d\phi \quad \dots (\bar{a}_r \cdot \bar{a}_r = 1)$$

Now integrate over the surface of sphere of constant radius ' $r$ '.

$$\begin{aligned} \therefore \oint_S \bar{D} \cdot d\bar{S} &= \int_{\phi=0}^{2\pi} \int_{\theta=0}^{\pi} D_r r^2 \sin \theta d\theta d\phi \\ &= D_r r^2 [-\cos \theta]_0^{\pi} [\phi]_0^{2\pi} = 4\pi r^2 D_r \end{aligned}$$

$$\text{But } \oint_S \bar{D} \cdot d\bar{S} = Q$$

$$\therefore Q = 4\pi r^2 D_r$$

$$\therefore D_r = \frac{Q}{4\pi r^2} \text{ and hence}$$

$$\boxed{\begin{aligned} \bar{D} &= D_r \bar{a}_r = \frac{Q}{4\pi r^2} \bar{a}_r \\ \bar{E} &= \frac{\bar{D}}{\epsilon_0} = \frac{Q}{4\pi \epsilon_0 r^2} \bar{a}_r \end{aligned}}$$

and

### 3.8.2 Infinite Line Charge

Consider an infinite line charge of density  $\rho_l$  C/m lying along z-axis from  $-\infty$  to  $+\infty$ . This is shown in the Fig. 3.11.

Consider the Gaussian surface as the right circular cylinder with z-axis as its axis and radius  $r$  as shown in the Fig. 3.11. The length of the cylinder is  $L$ .

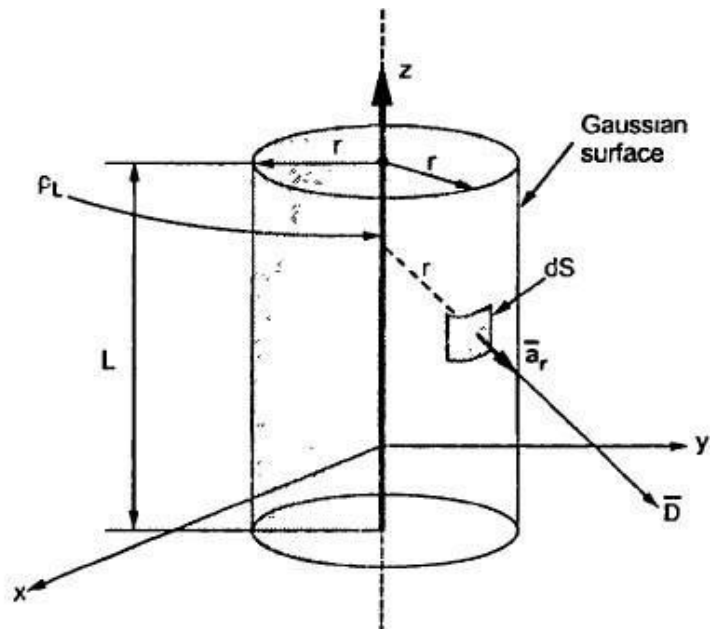


Fig. 3.11 Infinite line charge

The flux density at any point on the surface is directed radially outwards i.e in the  $\bar{a}_r$  direction according to cylindrical co-ordinate system.

Consider differential surface area  $dS$  as shown which is at a radial distance  $r$  from the line charge. The direction normal to  $dS$  is  $\bar{a}_r$ .

As the line charge is along  $z$ -axis, there can not be any component of  $\bar{D}$  in  $z$  direction. So  $\bar{D}$  has only radial component.

$$\text{Now} \quad Q = \oint_S \bar{D} \cdot d\bar{S}$$

The integration is to be evaluated for side surface, top surface and bottom surface.

$$\therefore Q = \oint_{\text{side}} \bar{D} \cdot d\bar{S} + \oint_{\text{top}} \bar{D} \cdot d\bar{S} + \oint_{\text{bottom}} \bar{D} \cdot d\bar{S}$$

$$\text{Now} \quad \bar{D} = D_r \bar{a}_r \quad \text{as has only radial component}$$

$$\text{and} \quad d\bar{S} = r d\phi dz \bar{a}_r \quad \text{normal to } \bar{a}_r \text{ direction.}$$

$$\therefore \bar{D} \cdot d\bar{S} = D_r r d\phi dz (\bar{a}_r \cdot \bar{a}_r) = D_r r d\phi dz \quad \dots \text{ as } \bar{a}_r \cdot \bar{a}_r = 1$$

Now  $D_r$  is constant over the side surface.

As  $\bar{D}$  has only radial component and no component along  $\bar{a}_z$  and  $-\bar{a}_z$  hence integrations over top and bottom surfaces is zero.

$$\therefore \oint_{\text{top}} \bar{D} \cdot d\bar{S} = \oint_{\text{bottom}} \bar{D} \cdot d\bar{S} = 0$$

$$\begin{aligned} \therefore Q &= \oint_{\text{side}} \bar{D} \cdot d\bar{S} = \oint_{\text{side}} D_r r d\phi dz \\ &= \int_{z=0}^L \int_{\phi=0}^{2\pi} D_r r d\phi dz = r D_r [z]_0^L [\phi]_0^{2\pi} \end{aligned}$$

$$\therefore Q = 2\pi r D_r L \quad \dots (4)$$

$$\therefore D_r = \frac{Q}{2\pi r L}$$

$$\therefore \bar{D} = D_r \bar{a}_r = \frac{Q}{2\pi r L} \bar{a}_r$$

$$\text{But} \quad \frac{Q}{L} = \rho_L \text{ C/m}$$

$$\therefore \boxed{\bar{D} = \frac{\rho_L}{2\pi r} \bar{a}_r \text{ C/m}^2} \quad \dots \text{ Due to infinite line charge.}$$

$$\text{and} \quad \bar{E} = \frac{\bar{D}}{\epsilon_0} = \frac{\rho_L}{2\pi \epsilon_0 r} \bar{a}_r \text{ V/m}$$



### 3.11 Maxwell's First Equation

The divergence of electric flux density  $\bar{D}$  is given by,

$$\begin{aligned}\text{div } \bar{D} &= \lim_{\Delta v \rightarrow 0} \frac{\oint_S \bar{D} \cdot d\bar{S}}{\Delta v} \quad \dots (1) \\ &= \frac{\partial D_x}{\partial x} + \frac{\partial D_y}{\partial y} + \frac{\partial D_z}{\partial z}\end{aligned}$$

According to Gauss's law, it is known that

$$\psi = Q = \oint_S \bar{D} \cdot d\bar{S} \quad \dots (2)$$

Expressing Gauss's law per unit volume basis

$$\frac{Q}{\Delta v} = \frac{\oint_S \bar{D} \cdot d\bar{S}}{\Delta v} \quad \dots (3)$$

Taking  $\lim_{\Delta v \rightarrow 0}$  i.e. volume shrinks to zero,

$$\lim_{\Delta v \rightarrow 0} \frac{Q}{\Delta v} = \lim_{\Delta v \rightarrow 0} \frac{\oint_S \bar{D} \cdot d\bar{S}}{\Delta v} \quad \dots (4)$$

But  $\lim_{\Delta v \rightarrow 0} \frac{Q}{\Delta v} = \rho_v$  at that point ... (5)

The equation (5) gives the volume charge density at the point where divergence is obtained.

Equating (1) and (5),

$$\begin{aligned}\text{div } \bar{D} &= \rho_v \quad \dots (6) \\ \text{i.e. } \nabla \cdot \bar{D} &= \rho_v\end{aligned}$$

This is volume charge density around a point. The equation (6) is called Maxwell's first equation applied to electrostatics. This is also called the point form of Gauss's law or Gauss's law in differential form.

## 6.2 Poisson's and Laplace's Equations

From the Gauss's law in the point form, Poisson's equation can be derived. Consider the Gauss's law in the point form as,

$$\nabla \cdot \bar{D} = \rho_v \quad \dots (1)$$

where  $\bar{D}$  = Flux density and  $\rho_v$  = Volume charge density

It is known that for a homogeneous, isotropic and linear medium, flux density and electric field intensity are directly proportional. Thus,

$$\bar{D} = \epsilon \bar{E} \quad \dots (2)$$

$$\therefore \nabla \cdot \epsilon \bar{E} = \rho_v \quad \dots (3)$$

From the gradient relationship,

$$\bar{E} = -\nabla V \quad \dots (4)$$

Substituting (4) in (3),

$$\nabla \cdot \epsilon(-\nabla V) = \rho_v \quad \dots (5)$$

Taking  $-\epsilon$  outside as constant,

$$-\epsilon[\nabla \cdot \nabla V] = \rho_v$$

$$\therefore \nabla \cdot \nabla V = -\frac{\rho_v}{\epsilon} \quad \dots (6)$$

Now  $\nabla \cdot \nabla$  operation is called 'del squared' operation and denoted as  $\nabla^2$ .

$$\therefore \boxed{\nabla^2 V = -\frac{\rho_v}{\epsilon}} \quad \dots (7)$$

This equation (7) is called **Poisson's equation**.

If in a certain region, volume charge density is zero ( $\rho_v = 0$ ), which is true for dielectric medium then the Poisson's equation takes the form,

$$\boxed{\nabla^2 V = 0} \quad (\text{For charge free region})$$

This is special case of Poisson's equation and is called **Laplace's equation**. The  $\nabla^2$  operation is called the **Laplacian of V**.

**Key Point:** Note that if  $\rho_v = 0$ , still in that region point charges, line charges and surface charges may exist at singular locations.

The equation (7) is for homogeneous medium for which  $\epsilon$  is constant. But if  $\epsilon$  is not constant and the medium is inhomogeneous, then equation (5) must be used as Poisson's equation for inhomogeneous medium.

## UNIT – II CONDUCTORS AND DIELECTRICS

Behavior of Conductors in an Electric Field-Conductors and Insulators – Electric Field inside a Dielectric Material – Polarization – Dielectric Conductors and Dielectric Boundary Conditions – Capacitance-Capacitance of Parallel Plate, Spherical & Co-axial capacitors – Energy Stored and Energy Density in a Static Electric Field – Current Density – Conduction and Convection Current Densities – Ohm’s Law in Point Form – Equation of Continuity – Numerical Problems.

### 5.2 Current and Current Density

The current is defined as the rate of flow of charge and is measured in amperes.

**Key Point :** *A current of 1 ampere is said to be flowing across the surface when a charge of one coulomb is passing across the surface in one second.*

The current is considered to be the motion of the positive charges. The conventional current is due to the flow of electrons, which are negatively charged. Hence the direction of conventional current is assumed to be opposite to the direction of flow of the electrons.

The current which exists in the conductors, due to the drifting of electrons, under the influence of the applied voltage is called **drift current**.

While in dielectrics, there can be flow of charges, under the influence of the electric field intensity. Such a current is called the **displacement current** or **convection current**. The current flowing across the capacitor, through the dielectric separating its plates is an example of the convection current.

The analysis of such currents, in the field theory is based on defining a current density at a point in the field.

The current density is a vector quantity associated with the current and denoted as  $\vec{J}$ .

### 5.2.1 Relation between I and $\bar{J}$

Consider a surface S and I is the current passing through the surface. The direction of current is normal to the surface S and hence direction of  $\bar{J}$  is also normal to the surface S.

Consider an incremental surface area  $dS$  as shown in the Fig. 5.1 (a) and  $\bar{a}_n$  is the unit vector normal to the incremental surface  $dS$ .

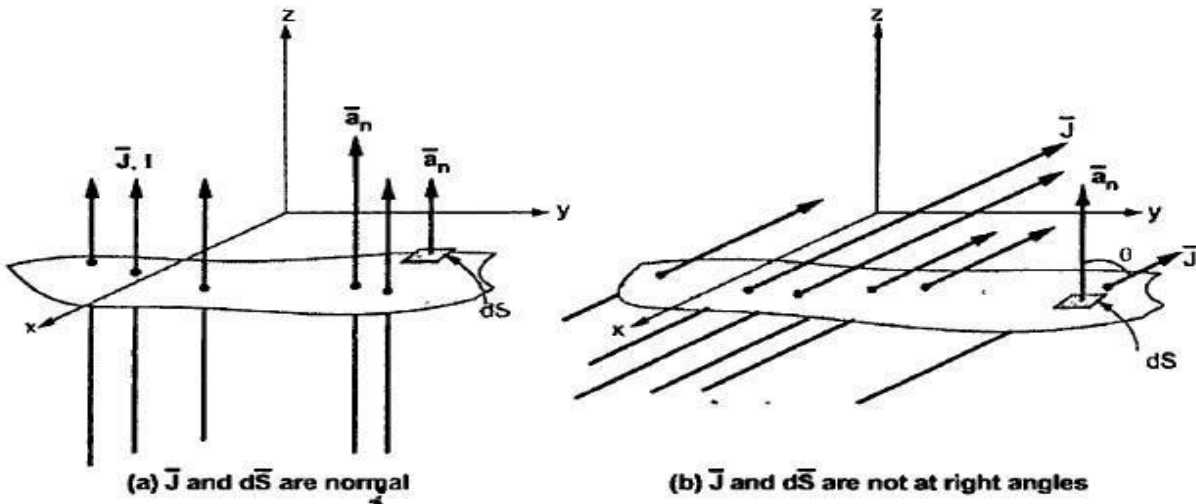


Fig. 5.1

$$\therefore d\bar{S} = dS \bar{a}_n \quad \text{while} \quad \bar{J} = J \bar{a}_n \quad \dots (1)$$

Then the differential current  $dI$  passing through the differential surface  $dS$  is given by the dot product of the current density vector  $\bar{J}$  and  $d\bar{S}$ .

$$\therefore dI = \bar{J} \cdot d\bar{S} \quad (\text{dot product}) \quad \dots (2)$$

When  $\bar{J}$  and  $d\bar{S}$  are at right angles ( $\theta = 90^\circ$ ) then

$$dI = J \bar{a}_n \cdot dS \bar{a}_n = J dS \quad \dots (3)$$

$$\text{and} \quad I = \int_S J dS \quad \dots (4)$$

where  $J$  = Current density in  $A/m^2$ .

But if  $\bar{J}$  is not normal to the differential area  $d\bar{S}$  then the total current is obtained by integrating the incremental current which is dot product of  $\bar{J}$  and  $d\bar{S}$ , over the surface S. This is shown in the Fig. 5.1 (b). Thus in general,

$$I = \int_S \bar{J} \cdot d\bar{S} \quad (\text{Dot product}) \quad \dots (5)$$

Thus if  $\bar{J}$  is in  $A/m^2$  and  $d\bar{S}$  is in  $m^2$  then the current obtained is in amperes (A). It may be noted that  $\bar{J}$  need not be uniform over S and S need not be a plane surface.

### 5.2.2 Relation between $\bar{J}$ and $\rho_v$

The set of charged particles give rise to a charge density  $\rho_v$  in a volume  $v$ . The current density  $\bar{J}$  can be related to the velocity with which the volume charge density i.e. charged particles in volume  $v$  crosses the surface  $S$  at a point. This is shown in the Fig. 5.2. The velocity with which the charge is getting transferred is  $\bar{v}$  m/s. It is a vector quantity.

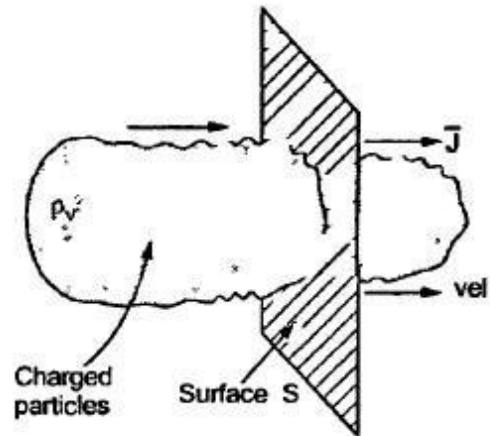


Fig. 5.2

To derive the relation between  $\bar{J}$  and  $\rho_v$ , consider differential volume  $\Delta v$  having charge density  $\rho_v$  as shown in the Fig. 5.3. The elementary charge that volume carries is,

$$\Delta Q = \rho_v \Delta v$$

... (6)

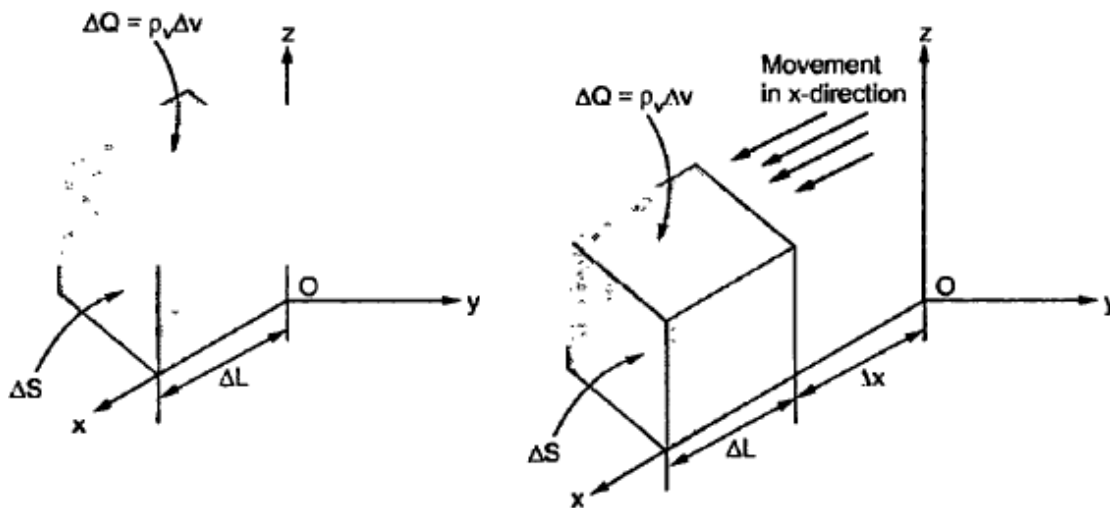


Fig. 5.3 Incremental charge moving in x-direction

Let  $\Delta l$  is the incremental length while  $\Delta S$  is the incremental surface area hence incremental volume is,

$$\Delta v = \Delta S \Delta L \quad \dots (7)$$

$$\therefore \Delta Q = \rho_v \Delta S \Delta L \quad \dots (8)$$

Let the charge is moving in x-direction with velocity  $\vec{v}$  and thus velocity has only x component  $v_x$ .

[Note : Velocity is denoted by small italic letter while the volume is denoted by small normal letter.]

In the time interval  $\Delta t$  the element of charge has moved through distance  $\Delta x$ , in x-direction as shown in the Fig. 5.3. The direction is normal to the surface  $\Delta S$  and hence resultant current can be expressed as,

$$\Delta I = \frac{\Delta Q}{\Delta t} \quad \dots (9)$$

But now,  $\Delta Q = \rho_v \Delta S \Delta x$  as the charge corresponding the length  $\Delta x$  is moved and responsible for the current.

$$\therefore \Delta I = \rho_v \Delta S \frac{\Delta x}{\Delta t} \quad \dots (10)$$

But  $\frac{\Delta x}{\Delta t} = \text{Velocity in x-direction i.e. } v_x$

$$\therefore \Delta I = \rho_v \Delta S v_x \quad \dots (11)$$

Note that  $v_x = x \text{ component of velocity } \vec{v}$

But  $\Delta I = \bar{J} \Delta S$  when  $\bar{J}$  and  $\Delta S$  are normal

Here  $\bar{J}$  and  $\Delta S$  are normal to each other hence comparing the two equations,

$$J_x = \rho_v v_x = x \text{ component of } \bar{J} \quad \dots (12)$$

In this case  $\bar{J}$  has only x component.

In general, the relation between  $J$  and  $\rho_v$  can be expressed as,

$$\boxed{\bar{J} = \rho_v \vec{v}} \quad \dots (13)$$

where  $\vec{v} = \text{Velocity vector}$

Such a current is called convection current and the current density is called convection current density.

**Key Point :** *The convection current density is linearly proportional to the charge density and the velocity with which the charge is transferred.*

### 5.3 Continuity Equation

The continuity equation of the current is based on the principle of conservation of charge. The principle states that,

The charges can neither be created nor be destroyed.

Consider a closed surface  $S$  with a current density  $\vec{J}$ , then the total current  $I$  crossing the surface  $S$  is given by,

$$I = \oint_S \vec{J} \cdot d\vec{S} \quad \dots (1)$$

The current flows outwards from the closed surface. It has been mentioned earlier that the current means the flow of positive charges. Hence the current  $I$  is constituted due to outward flow of positive charges from the closed surface  $S$ . According to principle of conservation of charge, there must be decrease of an equal amount of positive charge inside the closed surface. Hence the outward rate of flow of positive charge gets balanced by the rate of decrease of charge inside the closed surface.

Let  $Q_i$  = Charge within the closed surface

$$-\frac{dQ_i}{dt} = \text{Rate of decrease of charge inside the closed surface}$$

The negative sign indicates decrease in charge.

Due to principle of conservation of charge, this rate of decrease is same as rate of outward flow of charge, which is a current.

$$\therefore I = \oint_S \vec{J} \cdot d\vec{S} = -\frac{dQ_i}{dt} \quad \dots (2)$$

This is the integral form of the continuity equation of the current.

The negative sign in the equation indicates outward flow of current from the closed surface. So the equation (2) is indicating outward flowing current  $I$ .

If the current is entering the volume then

$$\oint_S \vec{J} \cdot d\vec{S} = -I = +\frac{dQ_i}{dt}$$

The point form of the continuity equation can be obtained from the integral form. Using the divergence theorem, convert the surface integral in integral form to the volume integral.

$$\therefore \oint_S \vec{J} \cdot d\vec{S} = \int_{\text{vol}} (\nabla \cdot \vec{J}) dv \quad \dots (3)$$

$$\therefore -\frac{dQ_i}{dt} = \int_{\text{vol}} (\nabla \cdot \vec{J}) dv \quad \dots (4)$$

$$\text{But } Q_i = \int_{\text{vol}} \rho_v dv \quad \dots (5)$$

where  $\rho_v$  = Volume charge density

$$\therefore \int_{\text{vol}} (\nabla \cdot \vec{J}) \, dv = -\frac{d}{dt} \left[ \int_{\text{vol}} \rho_v \, dv \right] = -\int_{\text{vol}} \frac{\partial \rho_v}{\partial t} \, dv \quad \dots (6)$$

For a constant surface, the derivative becomes the partial derivative.

$$\therefore \int_{\text{vol}} (\nabla \cdot \vec{J}) \, dv = \int_{\text{vol}} -\frac{\partial \rho_v}{\partial t} \, dv \quad \dots (7)$$

If the relation is true for any volume, it must be true even for incremental volume  $\Delta v$ .

$$\therefore (\nabla \cdot \vec{J}) \Delta v = -\frac{\partial \rho_v}{\partial t} \Delta v \quad \dots (8)$$

$$\therefore \boxed{\nabla \cdot \vec{J} = -\frac{\partial \rho_v}{\partial t}} \quad \dots (9)$$

This is the point form or differential form of the continuity equation of the current.

The equation states that the current or the charge per second, diverging from a small volume per unit volume is equal to the time rate of decrease of charge per unit volume at every point.

### 5.3.1 Steady Current

For steady currents which are not the functions of time,  $\partial \rho_v / \partial t = 0$  hence,

$$\boxed{\nabla \cdot \vec{J} = 0 \quad (\text{Steady current})} \quad \dots (10)$$

For such currents, the rate of flow of charge remains constant with time. The steady currents have no sources or sinks, as it is constant.

## 5.4 Conductors

Let us study the behaviour and properties of the conductors. Under the effect of applied electric field, the available free electrons start moving. The moving electrons strike the adjacent atoms and rebound in the random directions. This is called drifting of the electrons. After some time, the electrons attain the constant average velocity called drift



velocity ( $v_d$ ). The current constituted due to the drifting of such electrons in metallic conductors is called **drift current**. The drift velocity is directly proportional to the applied electric field.

$$\therefore \bar{v}_d \propto \bar{E} \quad \dots (1)$$

The constant of proportionality is called **mobility** of the electrons in a given material and denoted as  $\mu_e$ . It is positive for the electrons.

$$\therefore \boxed{\bar{v}_d = -\mu_e \bar{E}} \quad \dots (2)$$

The **negative sign** indicates that the velocity of the electrons is against the direction of field  $\bar{E}$ .

$$\text{Now } \mu \text{ (Mobility)} = \frac{\text{Velocity}}{\text{Field}} = \frac{\text{m/s}}{\text{V/m}} = \frac{\text{m}^2}{\text{V-s}}$$

Thus mobility is measured in square metres per volt-second ( $\text{m}^2/\text{V-s}$ ). The typical values of mobility are 0.0012 for aluminium, 0.0032 for copper etc.

According to relation between  $\bar{J}$  and  $\bar{v}$  we can write,

$$\bar{J} = \rho_v \bar{v} \quad \dots (3)$$

But in the material, the number of protons and electrons is same and it is always electrically neutral. Hence  $\rho_v = 0$  for the neutral materials. The drift velocity is the velocity of free electrons hence the above relation can be expressed as,

$$\boxed{\bar{J} = \rho_e \bar{v}_d} \quad \dots (4)$$

where  $\rho_e$  = Charge density due to free electrons

The charge density  $\rho_e$  can be obtained as the product of number of free electrons/ $\text{m}^3$  and the charge 'e' on one electron. Thus  $\rho_e = ne$  where n is number of free electrons per  $\text{m}^3$ .

Substituting equation (2) in equation (4) we get,

$$\boxed{\bar{J} = -\rho_e \mu_e \bar{E}} \quad \dots (5)$$

#### 5.4.1 Point Form of Ohm's Law

The relationship between  $\bar{J}$  and  $\bar{E}$  can also be expressed in terms of conductivity of the material.

Thus for a metallic conductor,

$$\boxed{\bar{J} = \sigma \bar{E}} \quad \dots (6)$$

where  $\sigma$  = Conductivity of the material

The conductivity is measured in mhos per metre ( $\text{O/m}$ ). The equation (6) is called **point form of Ohm's law**. The unit of conductivity is also called Siemens per metre ( $\text{S/m}$ ).

The typical values of conductivity are  $3.82 \times 10^7$  for aluminium,  $5.8 \times 10^7$  for copper etc. expressed in mho/m. For the metallic conductors the conductivity is constant over wide ranges of current density and electric field intensity. In all directions, metallic conductors have same properties hence called isotropic in nature. Such materials obey the Ohm's law very faithfully.

Comparing the equation (5) and equation (6) we can write,

$$\sigma = -\rho_e \mu_e \quad \dots (7)$$

This is conductivity in terms of mobility of the charge density of the electrons.

The resistivity is the reciprocal of the conductivity. The conductivity depends on the temperature. As the temperature increases, the vibrations of crystalline structure of atoms increases. Due to increased vibrations of electrons, drift velocity decreases, hence the mobility and conductivity decreases. So as temperature increases, the conductivity decreases and resistivity increases.

#### 5.4.2 Resistance of a Conductor

Consider that the voltage  $V$  is applied to a conductor of length  $L$  having uniform cross-section  $S$ , as shown in the Fig. 5.5.

The direction of  $\vec{E}$  is same as the direction of conventional current, which is opposite to the flow of electrons. The electric field applied is uniform and its magnitude is given by,

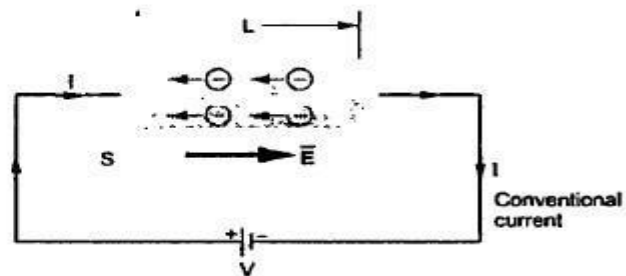


Fig. 5.5 Conductor subjected to voltage  $V$

$$E = \frac{V}{L} \quad \dots (8)$$

The conductor has uniform cross-section  $S$  and hence we can write,

$$I = \int_S \vec{J} \cdot d\vec{S} = JS \quad \dots (9)$$

The current direction is normal to the surface  $S$ .

Thus, 
$$J = \frac{I}{S} = \sigma E \quad \dots (10)$$

And using equation (8) in equation (10) we get,

$$J = \frac{\sigma V}{L} \quad \text{where } \sigma = \text{Conductivity of the material} \quad \dots (11)$$

$$\therefore V = \frac{JL}{\sigma} = \frac{IL}{\sigma S} = \left( \frac{L}{\sigma S} \right) I \quad \dots (12)$$

$$\therefore \boxed{R = \frac{V}{I} = \frac{L}{\sigma S}} \quad \dots (13)$$

Thus the ratio of potential difference between the two ends of the conductors to the current flowing through it is resistance of the conductor.

The equation (12) is nothing but the Ohm's law in its normal form given by  $V = IR$ . The equation is true for the uniform fields and resistance is measured in ohms ( $\Omega$ ).

For nonuniform fields, the resistance  $R$  is defined as the ratio  $V$  to  $I$  where  $V$  is the potential difference between two specified equipotential surfaces in the material and  $I$  is the current crossing the more positive surface of the two, into the material. Mathematically the resistance for nonuniform fields is given by,

$$\boxed{R = \frac{V_{ab}}{I} = \frac{-\int_a^b \vec{E} \cdot d\vec{L}}{\int_s \vec{J} \cdot d\vec{S}} = \frac{-\int_a^b \vec{E} \cdot d\vec{L}}{\int_s \sigma \vec{E} \cdot d\vec{S}}} \quad \dots (14)$$

The numerator is a line integration giving potential difference across two ends while the denominator is a surface integration giving current flowing through the material.

The resistance can also be expressed as,

$$\boxed{R = \frac{L}{\sigma S} = \frac{\rho_c L}{S} \Omega} \quad \dots (15)$$

where  $\rho_c = \frac{1}{\sigma} = \text{Resistivity of the conductor in } \Omega\text{-m}$

### 5.4.3 Properties of Conductor

Consider that the charge distribution is suddenly unbalanced inside the conductor. There are number of electrons trying to reside inside the conductor. All the electrons are negatively charged and they start repelling each other due to their own electric fields. Such electrons get accelerated away from each other, till all the electrons causing interior imbalance, reach at the surface of the conductor. The conductor is surrounded by the insulating medium and hence electrons just driven from the interior of the conductor, reside over the surface. Thus,

1. Under static conditions, no charge and no electric field can exist at any point **within the conducting material.**
2. The charge can exist on the surface of the conductor giving rise to surface charge density.
3. Within a conductor, the charge density is always zero.
4. The charge distribution on the surface depends on the shape of the surface.
5. The conductivity of an ideal conductor is infinite.
6. The conductor surface is an equipotential surface.

## 5.6 Dielectric Materials

It is seen that the conductors have large number of free electrons while insulators and dielectric materials do not have free charges. The charges in dielectrics are bound by the finite forces and hence called **bound charges**. As they are bound and not free, they cannot contribute to the conduction process. But if subjected to an electric field  $\vec{E}$ , they shift their relative positions, against the normal molecular and atomic forces. This shift in the relative positions of bound charges, allows the dielectric to store the energy.

The shifts in positive and negative charges are in opposite directions and under the influence of an applied electric field  $\vec{E}$  such charges act like small electric dipoles.

**Key Point :** *When the dipole results from the displacement of the bound charges, the dielectric is said to be polarized.*

And these electric dipoles produce an electric field which opposes the externally applied electric field. This process, due to which separation of bound charges results to produce electric dipoles, under the influence of electric field  $\vec{E}$ , is called **polarization**.

### 5.6.1 Polarization

To understand the polarization, consider an atom of a dielectric. This consists of a nucleus with positive charge and negative charges in the form of revolving electrons in the orbits. The negative charge is thus considered to be in the form of cloud of electrons. This is shown in the Fig. 5.6.

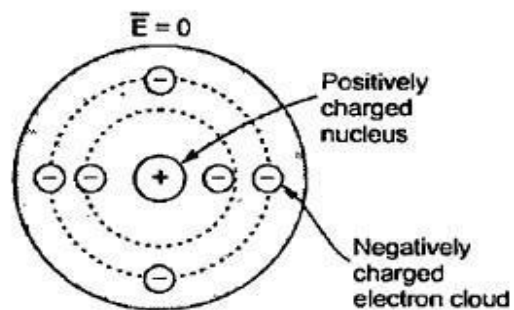
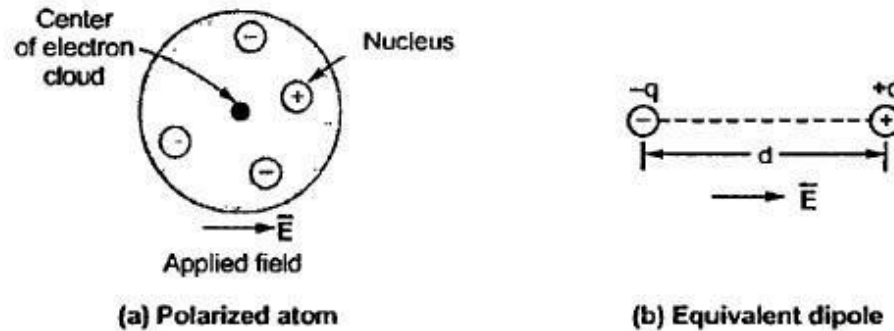


Fig. 5.6 Unpolarized atom of a dielectric

Note that  $\vec{E}$  applied is zero. The number of positive charges is same as negative charges and hence atom is electrically neutral. Due to symmetry, both positive and negative charges can be assumed to be point charges of equal amount, coinciding at the centre. Hence there cannot exist an electric dipole. This is called **unpolarized atom**.

When electric field  $\vec{E}$  is applied, the symmetrical distribution of charges gets disturbed. The positive charges experience a force  $\vec{F} = Q\vec{E}$  while the negative charges experience a force  $\vec{F} = -Q\vec{E}$  in the opposite direction.

Now there is separation between the nucleus and the centre of the electron cloud as shown in the Fig. 5.7 (a). Such an atom is called **polarized atom**.



**Fig. 5.7**

It can be seen that an electron cloud has a centre separated from the nucleus. This forms an electric dipole. The equivalent dipole formed is shown in the Fig. 5.7 (b). The dipole gets aligned with the applied field. This process is called **polarization of dielectrics**.

There are two types of dielectrics,

1. Nonpolar and 2. Polar.

In **nonpolar** molecules, the dipole arrangement is totally absent, in absence of electric field  $\vec{E}$ . It results only when an externally field  $\vec{E}$  is applied to it. In **polar** molecules, the permanent displacements between centres of positive and negative charges exist. Thus dipole arrangements exist without application of  $\vec{E}$ . But such dipoles are randomly oriented. Under the application of  $\vec{E}$ , the dipoles experience torque and they align with the direction of the applied field  $\vec{E}$ . This is called **polarization of polar molecules**.

The examples of nonpolar molecules are hydrogen, oxygen and the rare gases. The examples of polar molecules are water, sulphur dioxide, hydrochloric acid etc.

## 5.7 Boundary Conditions

When an electric field passes from one medium to other medium, it is important to study the conditions at the boundary between the two media. The conditions existing at the boundary of the two media when field passes from one medium to other are called **boundary conditions**. Depending upon the nature of the media, there are two situations of the boundary conditions,

1. Boundary between conductor and free space.
2. Boundary between two dielectrics with different properties.

The free space is nothing but a dielectric hence first case is nothing but the boundary between conductor and a dielectric. For studying the boundary conditions, the Maxwell's equations for electrostatics are required.

$$\oint \vec{E} \cdot d\vec{L} = 0 \quad \text{and} \quad \oint \vec{D} \cdot d\vec{S} = Q$$

Similarly the field intensity  $\vec{E}$  is required to be decomposed into two components namely tangential to the boundary ( $\vec{E}_{tan}$ ) and normal to the boundary ( $\vec{E}_N$ ).

$$\therefore \quad \vec{E} = \vec{E}_{tan} + \vec{E}_N$$

Similar decomposition is required for flux density  $\vec{D}$  as well.

Let us study the various cases of boundary conditions in detail.

## 5.8 Boundary Conditions between Conductor and Free Space

Consider a boundary between conductor and free space. The conductor is ideal having infinite conductivity. Such conductors are copper, silver etc. having conductivity of the order of  $10^6$  S/m and can be treated ideal. For ideal conductors it is known that,

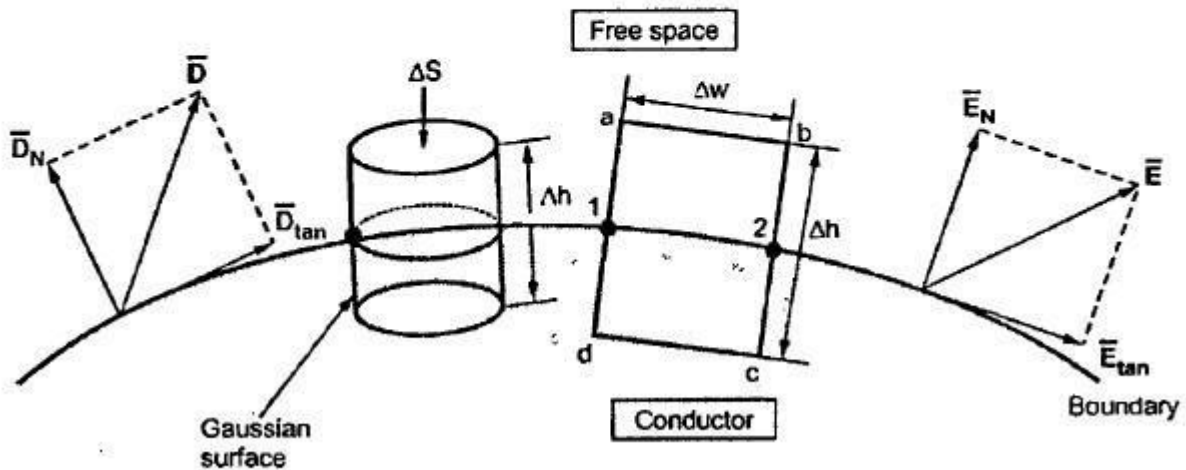
1. The field intensity inside a conductor is zero and the flux density inside a conductor is zero.
2. No charge can exist within a conductor. The charge appears on the surface in the form of surface charge density.

3. The charge density within the conductor is zero.

Thus  $\vec{E}$ ,  $\vec{D}$  and  $\rho_v$  within the conductor are zero. While  $\rho_s$  is the surface charge density on the surface of the conductor.

To determine the boundary conditions let us use the closed path and the Gaussian surface.

Consider the conductor free space boundary as shown in the Fig. 5.8.



**Fig. 5.8 Boundary between conductor and free space**

### 5.8.1 $\vec{E}$ at the Boundary

Let  $\vec{E}$  be the electric field intensity, in the direction shown in the Fig. 5.11, making some angle with the boundary. This  $\vec{E}$  can be resolved into two components :

1. The component tangential to the surface ( $\vec{E}_{tan}$ ).
2. The component normal to the surface ( $\vec{E}_N$ ).

It is known that,

$$\oint \vec{E} \cdot d\vec{L} = 0 \quad \dots (1)$$

The integral of  $\vec{E} \cdot d\vec{L}$  carried over a closed contour is zero i.e. work done in carrying unit positive charge along a closed path is zero.

Consider a rectangular closed path  $abcd$  as shown in the Fig. 5.8. It is traced in clockwise direction as  $a-b-c-d-a$  and hence  $\oint \vec{E} \cdot d\vec{L}$  can be divided into four parts.

$$\oint \vec{E} \cdot d\vec{L} = \int_a^b \vec{E} \cdot d\vec{L} + \int_b^c \vec{E} \cdot d\vec{L} + \int_c^d \vec{E} \cdot d\vec{L} + \int_d^a \vec{E} \cdot d\vec{L} = 0 \quad \dots (2)$$

The closed contour is placed in such a way that its two sides  $a-b$  and  $c-d$  are parallel to tangential direction to the surface while the other two are normal to the surface, at the boundary.

The rectangle is an elementary rectangle with elementary height  $\Delta h$  and elementary width  $\Delta w$ . The rectangle is placed in such a way that half of it is in the conductor and remaining half is in the free space. Thus  $\Delta h/2$  is in the conductor and  $\Delta h/2$  is in the free space.

Now the portion c-d is in the conductor where  $\vec{E} = 0$  hence the corresponding integral is zero.

$$\therefore \int_a^b \vec{E} \cdot d\vec{L} + \int_b^c \vec{E} \cdot d\vec{L} + \int_c^d \vec{E} \cdot d\vec{L} = 0 \quad \dots (3)$$

As the width  $\Delta w$  is very small,  $E$  over it can be assumed constant and hence can be taken out of integration.

$$\therefore \int_a^b \vec{E} \cdot d\vec{L} = \vec{E} \int_a^b d\vec{L} = \vec{E}(\Delta w) \quad \dots (4)$$

But  $\Delta w$  is along tangential direction to the boundary in which direction  $\vec{E} = \vec{E}_{tan}$ .

$$\therefore \int_a^b \vec{E} \cdot d\vec{L} = E_{tan}(\Delta w) \quad \text{where} \quad E_{tan} = |\vec{E}_{tan}| \quad \dots (5)$$

Now b-c is parallel to the normal component so we have  $\vec{E} = \vec{E}_N$  along this direction. Let  $E_N = |\vec{E}_N|$ .

Over the small height  $\Delta h$ ,  $E_N$  can be assumed constant and can be taken out of integration.

$$\therefore \int_b^c \vec{E} \cdot d\vec{L} = \vec{E} \int_b^c d\vec{L} = E_N \int_b^c d\vec{L} \quad \dots (6)$$

But out of b-c, b-2 is in free space and 2-c is in the conductor where  $\vec{E} = 0$ .

$$\therefore \int_b^c d\vec{L} = \int_b^2 d\vec{L} + \int_2^c d\vec{L} = \frac{\Delta h}{2} + 0 = \frac{\Delta h}{2} \quad \dots (7)$$

$$\therefore \int_b^c \vec{E} \cdot d\vec{L} = E_N \left( \frac{\Delta h}{2} \right) \quad \dots (8)$$

Similarly for path d-a, the condition is same as for the path b-c, only direction is opposite.

$$\therefore \int_d^a \vec{E} \cdot d\vec{L} = -E_N \left( \frac{\Delta h}{2} \right) \quad \dots (9)$$

Substituting equations (4), (8) and equation (9) in (3) we get,

$$\therefore E_{tan} \Delta w + E_N \left( \frac{\Delta h}{2} \right) - E_N \left( \frac{\Delta h}{2} \right) = 0 \quad \dots (10)$$



$$\therefore E_{\text{tan}} \Delta w = 0$$

But  $\Delta w \neq 0$  as finite

$$\therefore \boxed{E_{\text{tan}} = 0} \quad \dots (11)$$

Thus the tangential component of the electric field intensity is zero at the boundary between conductor and free space.

**Key Point :** Thus the  $\vec{E}$  at the boundary between conductor and free space is always in the direction perpendicular to the boundary.

Now  $\vec{D} = \epsilon_0 \vec{E}$  for free space

$$\therefore \boxed{D_{\text{tan}} = \epsilon_0 E_{\text{tan}} = 0} \quad \dots (12)$$

Thus the tangential component of electric flux density is zero at the boundary between conductor and free space.

**Key Point :** Hence electric flux density  $\vec{D}$  is also only in the normal direction at the boundary between the conductor and the free space.

### 5.8.2 $D_N$ at the Boundary

To find normal component of  $\vec{D}$ , select a closed Gaussian surface in the form of right circular cylinder as shown in the Fig. 5.8. Its height is  $\Delta h$  and is placed in such a way that  $\Delta h/2$  is in the conductor and remaining  $\Delta h/2$  is in the free space. Its axis is in the normal direction to the surface.

According to Gauss's law,  $\oint_S \bar{D} \cdot d\bar{S} = Q$

The surface integral must be evaluated over three surfaces,

i) Top, ii) Bottom and iii) Lateral.

Let the area of top and bottom is same equal to  $\Delta S$ .

$$\therefore \int_{\text{top}} \bar{D} \cdot d\bar{S} + \int_{\text{bottom}} \bar{D} \cdot d\bar{S} + \int_{\text{lateral}} \bar{D} \cdot d\bar{S} = Q \quad \dots (13)$$

The bottom surface is in the conductor where  $\bar{D} = 0$  hence corresponding integral is zero.

The top surface is in the free space and we are interested in the boundary condition hence top surface can be shifted at the boundary with  $\Delta h \rightarrow 0$ .

$$\therefore \int_{\text{top}} \bar{D} \cdot d\bar{S} + \int_{\text{lateral}} \bar{D} \cdot d\bar{S} = Q \quad \dots (14)$$

The lateral surface area is  $2\pi r \Delta h$  where  $r$  is the radius of the cylinder. But as  $\Delta h \rightarrow 0$ , this area reduces to zero and corresponding integral is zero.

While only component of  $\bar{D}$  present is the normal component having magnitude  $D_N$ . The top surface is very small over which  $D_N$  can be assumed constant and can be taken out of integration.

$$\therefore \int_{\text{top}} \bar{D} \cdot d\bar{S} = D_N \int_{\text{top}} d\bar{S} = D_N \Delta S \quad \dots (15)$$

From Gauss's law,

$$\therefore D_N \Delta S = Q \quad \dots (16)$$

But at the boundary, the charge exists in the form of surface charge density  $\rho_S \text{ C/m}^2$ .

$$\therefore Q = \rho_S \Delta S \quad \dots (17)$$

Equating equation (16) and (17),

$$\therefore D_N \Delta S = \rho_S \Delta S$$

$$\therefore \boxed{D_N = \rho_S} \quad \dots (18)$$

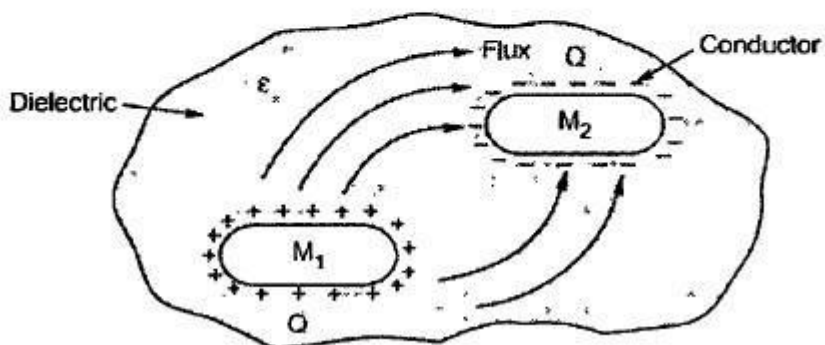
Thus the flux leaves the surface normally and the normal component of flux density is equal to the surface charge density.

$$\therefore D_N = \epsilon_0 E_N = \rho_S \quad \dots (19)$$

$$\therefore \boxed{E_N = \frac{\rho_S}{\epsilon_0}} \quad \dots (20)$$

## 5.10 Concept of Capacitance

Consider two conducting materials  $M_1$  and  $M_2$  which are placed in a dielectric medium having permittivity  $\epsilon$ . The material  $M_1$  carries a positive charge  $Q$  while the material  $M_2$  carries a negative charge, equal in magnitude as  $Q$ . There are no other charges present and total charge of the system is zero. In conductors, charge cannot reside within the conductor and it resides only on the surface. Thus for  $M_1$  and  $M_2$ , charges  $+Q$  and  $-Q$  reside on the surfaces of  $M_1$  and  $M_2$  respectively. This is shown in the Fig. 5.13.



**Fig. 5.13 Concept of capacitance**

Such a system which has two conducting surfaces carrying equal and opposite charges, separated by a dielectric is called **capacitive system** giving rise to a **capacitance**.

The electric field is normal to the conductor surface and the electric flux is directed from  $M_1$  towards  $M_2$  in such a system. There exists a potential difference between the two surfaces of  $M_1$  and  $M_2$ . Let this potential is  $V_{12}$ . The ratio of the magnitudes of the total charge on any one of the two conductors and potential difference between the conductors is called the **capacitance** of the two conductor system denoted as  $C$ .

$$\therefore C = \frac{Q}{V_{12}} \quad \dots (1)$$

$$\text{In general, } C = \frac{Q}{V} \quad \dots (2)$$

where  $Q$  = Charge in coulombs  
 $V$  = Potential difference in volts

The capacitance is measured in **farads (F)** and

$$1 \text{ Farad} = \frac{1 \text{ coulomb}}{1 \text{ volt}}$$

As charge  $Q$  resides only on the surface of the conductor, it can be obtained from the Gauss's law as,

$$Q = \oint_S \vec{D} \cdot d\vec{S} = \oint_S \epsilon_0 \epsilon_r \vec{E} \cdot d\vec{S} = \oint_S \epsilon \vec{E} \cdot d\vec{S}$$

While  $V$  is the work done in moving unit positive charge from negative to the positive surface and can be obtained as,

$$V = -\int \vec{E} \cdot d\vec{L} = -\int \vec{E} \cdot d\vec{L}$$

Hence capacitance can be expressed as,

$$C = \frac{Q}{V} = \frac{\oint \epsilon \vec{E} \cdot d\vec{S}}{-\int \vec{E} \cdot d\vec{L}} \quad \dots (3)$$

If the charge  $Q$  is increased, then  $\vec{E}$  and  $\vec{D}$  get increased by same factor. The voltage  $V$  also increases by same factor. Thus the ratio  $Q$  to  $V$  remains constant as  $C$ . Hence capacitance is not the function of charge, field intensity, flux density and potential difference.

### 5.12 Capacitors in Parallel

**Key Point:** When capacitors are in parallel, the same voltage exists across them, but charges are different.

$$Q_1 = C_1 V, \quad Q_2 = C_2 V, \quad Q_3 = C_3 V$$

The total charge stored by the parallel bank of capacitors  $Q$  is given by,

$$\begin{aligned} Q &= Q_1 + Q_2 + Q_3 \\ &= C_1 V + C_2 V + C_3 V = (C_1 + C_2 + C_3) V \end{aligned} \quad \dots (1)$$

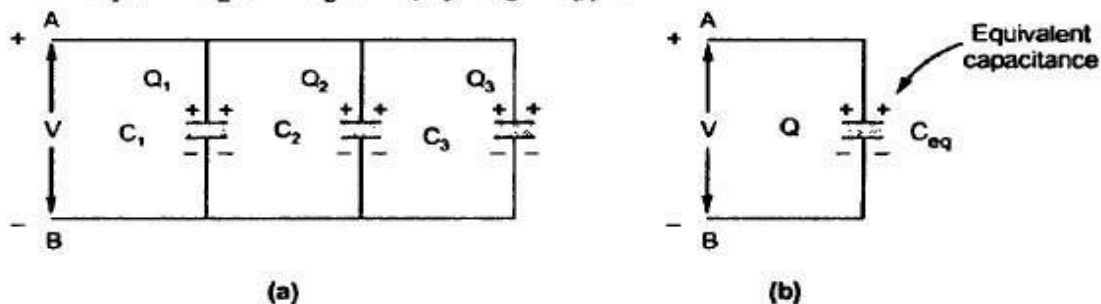


Fig. 5.15 Capacitors in parallel

An equivalent capacitor which stores the same charge  $Q$  at the same voltage  $V$ , will have

$$Q = C_{eq} V \quad \dots (2)$$

Comparing equation (1) and equation (2),

As  $C_{eq} = C_1 + C_2 + C_3$

$\therefore Q = C_1 V + C_2 V + C_3 V$

It is easy to find  $Q_1, Q_2$  and  $Q_3$  if  $V$  is known.

For 'n' capacitors in parallel,  $C_{eq} = C_1 + C_2 + \dots + C_n$

### 5.13 Parallel Plate Capacitor

A parallel plate capacitor is shown in the Fig. 5.16. It consists of two parallel metallic plates separated by distance 'd'. The space between the plates is filled with a dielectric of permittivity  $\epsilon$ . The lower plate, plate 1 carries the positive charge and is distributed over it with a charge density  $+\rho_s$ . The upper plate, plate 2 carries the negative charge and is distributed over its surface with a charge density  $-\rho_s$ . The plate 1 is placed in  $z = 0$  i.e. xy plane hence normal to it is z-direction. While upper plate 2 is in  $z = d$  plane, parallel to xy plane.

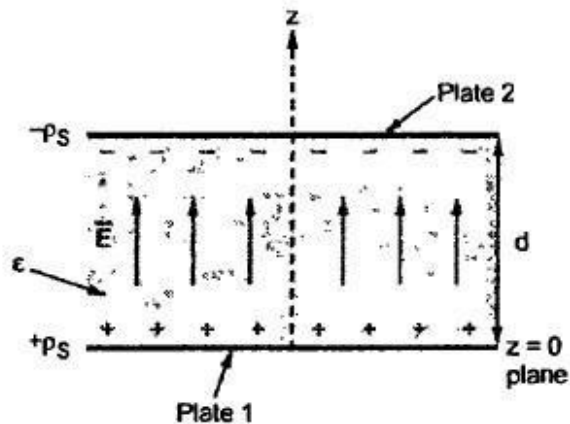


Fig. 5.16

Let  $A =$  Area of cross section of the plates in  $m^2$ .

$\therefore Q = \rho_s A C \quad \dots (1)$

This is magnitude of charge on any one plate as charge carried by both is equal in magnitude. To find potential difference, let us obtain  $\bar{E}$  between the plates.

Assuming plate 1 to be infinite sheet of charge,

$$\bar{E}_1 = \frac{\rho_s}{2\epsilon} \bar{a}_N = \frac{\rho_s}{2\epsilon} \bar{a}_z \quad \text{V/m} \quad \dots (2)$$

The  $\bar{E}_1$  is normal at the boundary between conductor and dielectric without any tangential component.

While for plate 2, we can write

$$\bar{E}_2 = \frac{-\rho_s}{2\epsilon} \bar{a}_N = \frac{-\rho_s}{2\epsilon} (-\bar{a}_z) \quad \text{V/m} \quad \dots (3)$$

The direction of  $\bar{E}_2$  is downwards i.e. in  $-\bar{a}_z$  direction.

In between the plates,

$$\bar{E} = \bar{E}_1 + \bar{E}_2 = \frac{\rho_s}{2\epsilon} \bar{a}_z + \frac{\rho_s}{2\epsilon} \bar{a}_z = \frac{\rho_s}{\epsilon} \bar{a}_z \quad \dots (4)$$

The potential difference is given by,

$$V = -\int_{-}^{+} \bar{E} \cdot d\bar{L} = -\int_{\text{upper}}^{\text{lower}} \frac{\rho_s}{\epsilon} \bar{a}_z \cdot d\bar{L}$$

Now  $d\bar{L} = dx \bar{a}_x + dy \bar{a}_y + dz \bar{a}_z$  in Cartesian system.

$$\therefore V = - \int_{z=d}^{z=0} \frac{\rho_s}{\epsilon} \bar{a}_z \cdot [dx \bar{a}_x + dy \bar{a}_y + dz \bar{a}_z]$$

$$= - \int_{z=d}^{z=0} \frac{\rho_s}{\epsilon} dz = - \frac{\rho_s}{\epsilon} [z]_d^0 = - \frac{\rho_s [-d]}{\epsilon}$$

$$\therefore V = \frac{\rho_s d}{\epsilon}$$

The capacitance is the ratio of charge Q to voltage V,

$$C = \frac{Q}{V} = \frac{\rho_s A}{\frac{\rho_s d}{\epsilon}} = \frac{\epsilon A}{d} \text{ F} \quad \dots (5)$$

Thus if,

$$\epsilon = \epsilon_0 \epsilon_r$$

$$C = \frac{\epsilon_0 \epsilon_r A}{d} \text{ F} \quad \dots (6)$$

It can be seen that the value of capacitance depends on,

1. The permittivity of the dielectric used.
2. The area of cross section of the plates.
3. The distance of separation of the plates.

It is not dependant on the charge or the potential difference between the plates.

## 5.14 Capacitance of a Co-axial Cable

Consider a co-axial cable or co-axial capacitor as shown in the Fig. 5.17.

Let a = Inner radius

b = Outer radius

The two concentric conductors are separated by dielectric of permittivity  $\epsilon$ .

The length of the cable is L m.

The inner conductor carries a charge density  $+\rho_l$  C/m on its surface then equal and opposite charge density  $-\rho_l$  C/m exists on the outer conductor.

$$\therefore Q = \rho_l \times L \quad \dots (1)$$

Assuming cylindrical co-ordinate system,  $\bar{E}$  will be radial from inner to outer conductor, and for infinite line charge it is given by,

$$\bar{E} = \frac{\rho_l}{2\pi\epsilon r} \bar{a}_r \quad \dots (2)$$

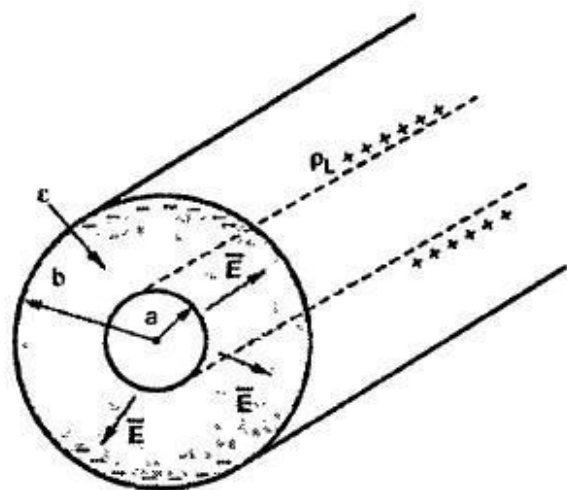


Fig. 5.17 Co-axial cable

$\vec{E}$  is directed from inner conductor to the outer conductor. The potential difference is work done in moving unit charge against  $\vec{E}$  i.e. from  $r = b$  to  $r = a$ .

To find potential difference, consider  $d\vec{L}$  in radial direction which is  $dr\vec{a}_r$ ,

$$\begin{aligned} \therefore V &= -\int_{-}^{+} \vec{E} \cdot d\vec{L} = -\int_{r=b}^{r=a} \frac{\rho_L}{2\pi\epsilon r} \vec{a}_r \cdot dr\vec{a}_r \\ &= -\frac{\rho_L}{2\pi\epsilon} [\ln r]_b^a = -\frac{\rho_L}{2\pi\epsilon} \ln\left[\frac{a}{b}\right] \end{aligned}$$

$$\therefore V = \frac{\rho_L}{2\pi\epsilon} \ln\left[\frac{b}{a}\right] \text{ V} \quad \dots (3)$$

$$\therefore C = \frac{Q}{V} = \frac{\rho_L \times L}{\frac{\rho_L}{2\pi\epsilon} \ln\left[\frac{b}{a}\right]}$$

$$\therefore C = \frac{2\pi\epsilon L}{\ln\left[\frac{b}{a}\right]} \text{ F} \quad \dots (4)$$

### 5.15 Spherical Capacitor

Consider a spherical capacitor formed of two concentric spherical conducting shells of radius  $a$  and  $b$ . The capacitor is shown in the Fig. 5.18.

The radius of outer sphere is 'b' while that of inner sphere is 'a'. Thus  $b > a$ . The region between the two spheres is filled with a dielectric of permittivity  $\epsilon$ . The inner sphere is given a positive charge  $+Q$  while for the outer sphere it is  $-Q$ .

Considering Gaussian surface as a sphere of radius  $r$ , it can be obtained that  $\vec{E}$  is in radial direction and given by,

$$\vec{E} = \frac{Q}{4\pi\epsilon r^2} \vec{a}_r, \text{ V/m} \quad \dots (1)$$

The potential difference is work done in moving unit positive charge against the direction of  $\vec{E}$  i.e. from  $r = b$  to  $r = a$ .

$$\therefore V = -\int_{-}^{+} \vec{E} \cdot d\vec{L} = -\int_{r=b}^{r=a} \frac{Q}{4\pi\epsilon r^2} \vec{a}_r \cdot d\vec{L} \quad \dots (2)$$

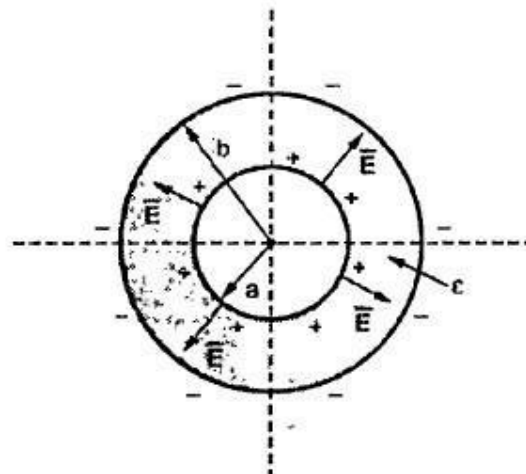


Fig. 5.18 Spherical capacitor



Now  $d\vec{L} = dr \vec{a}_r$  ... In radial direction

$$\begin{aligned} \therefore V &= - \int_{r=b}^{r=a} \frac{Q}{4\pi\epsilon r^2} \vec{a}_r \cdot dr \vec{a}_r = - \int_{r=b}^{r=a} \frac{Q}{4\pi\epsilon r^2} dr \\ &= - \frac{Q}{4\pi\epsilon} \left[ -\frac{1}{r} \right]_{r=b}^{r=a} = \frac{Q}{4\pi\epsilon} \left[ \frac{1}{r} \right]_{r=b}^{r=a} \end{aligned}$$

$$\therefore V = \frac{Q}{4\pi\epsilon} \left[ \frac{1}{a} - \frac{1}{b} \right] \quad \dots (3)$$

Now  $C = \frac{Q}{V} = \frac{Q}{\frac{Q}{4\pi\epsilon} \left[ \frac{1}{a} - \frac{1}{b} \right]}$

$$\therefore C = \frac{4\pi\epsilon}{\left[ \frac{1}{a} - \frac{1}{b} \right]} \text{ F} \quad \dots (4)$$

### 5.17 Energy Stored in a Capacitor

It is seen that capacitor can store the energy. Let us find the expression for the energy stored in a capacitor.

Consider a parallel plate capacitor as shown in the Fig. 5.25. It is supplied with the voltage  $V$ .

Let  $\vec{a}_N$  is the direction normal to the plates.

$$\therefore \vec{E} = \frac{V}{d} \vec{a}_N \quad \dots (1)$$

The energy stored is given by,

$$\begin{aligned} W_E &= \frac{1}{2} \int_{\text{vol}} \vec{D} \cdot \vec{E} \, dv \\ &= \frac{1}{2} \int_{\text{vol}} \epsilon \vec{E} \cdot \vec{E} \, dv && \text{but } \vec{E} \cdot \vec{E} = |\vec{E}|^2 \\ &= \frac{1}{2} \int_{\text{vol}} \epsilon |\vec{E}|^2 \, dv && \text{but } |\vec{E}| = \frac{V}{d} \\ &= \frac{1}{2} \epsilon \frac{V^2}{d^2} \int_{\text{vol}} dv && \text{but } \int_{\text{vol}} dv = \text{Volume} = A \times d \\ &= \frac{1}{2} \epsilon \frac{V^2 A d}{d^2} = \frac{1}{2} \frac{\epsilon A}{d} V^2 \end{aligned}$$

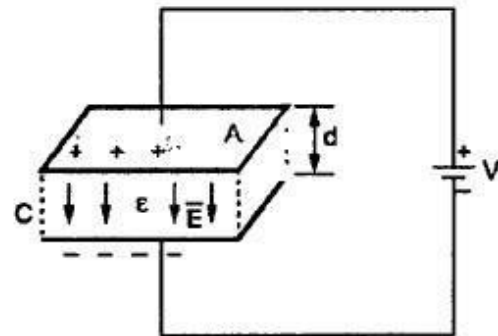


Fig. 5.25 Parallel plate capacitor

$$W_E = \frac{1}{2} CV^2 \text{ J}$$

If the dielectric is free space then there is increase in the stored energy if free space is replaced by other dielectric having  $\epsilon_r > 1$ .

### 5.17.1 Energy-Density

As seen in earlier chapter, energy density is the energy stored per unit volume as volume tends to zero.

$$\therefore W_E = \frac{1}{2} \epsilon \int_{\text{Vol}} |\bar{E}|^2 dv$$

$$\therefore W_E = \frac{1}{2} \epsilon |\bar{E}|^2 \text{ J/m}^3 = \text{Energy density}$$

Using  $|\bar{D}| = \epsilon |\bar{E}|$  we can write,

$$W_E = \frac{1}{2} \frac{|\bar{D}|^2}{\epsilon} = \frac{1}{2} |\bar{D}| |\bar{E}| \text{ J/m}^3$$

## UNIT – III MAGNETOSTATICS

Static Magnetic Fields – Biot-Savart Law – Oersted's experiment – Magnetic Field Intensity (MFI) due to a Straight, Circular & Solenoid Current Carrying Wire – Maxwell's Second Equation. Ampere's Circuital Law and its Applications Viz., MFI Due to an Infinite Sheet of Current and a Long Current Carrying Filament – Point Form of Ampere's Circuital Law – Maxwell's Third Equation – Numerical Problems.

Magnetic Force — Lorentz Force Equation – Force on Current Element in a Magnetic Field - Force on a Straight and Long Current Carrying Conductor in a Magnetic Field - Force Between two Straight and Parallel Current Carrying Conductors – Magnetic Dipole and Dipole moment – A Differential Current Loop as a Magnetic Dipole – Torque on a Current Loop Placed in a Magnetic Field – Numerical Problems.

### 7.3 Biot-Savart Law

Consider a conductor carrying a direct current  $I$  and a steady magnetic field produced around it. The Biot-Savart law allows us to obtain the differential magnetic field intensity  $d\vec{H}$ , produced at a point  $P$ , due to a differential current element  $I d\vec{L}$ . The current carrying conductor is shown in the Fig. 7.6.

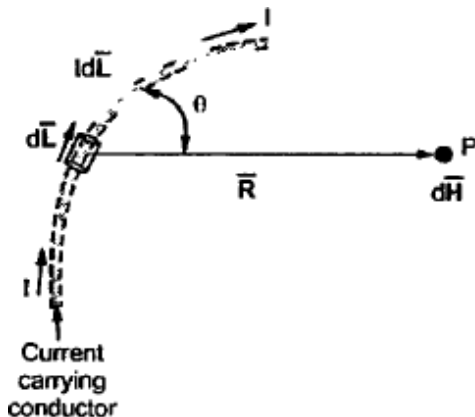


Fig. 7.6

Consider a differential length  $dL$  hence the differential current element is  $I dL$ . This is very small part of the current carrying conductor. The point  $P$  is at a distance  $R$  from the differential current element. The  $\theta$  is the angle between the differential current element and the line joining point  $P$  to the differential current element.

The Biot-Savart law states that,

The magnetic field intensity  $d\vec{H}$  produced at a point  $P$  due to a differential current element  $I dL$  is,

1. Proportional to the product of the current  $I$  and differential length  $dL$ .
2. The sine of the angle between the element and the line joining point  $P$  to the element.
3. And inversely proportional to the square of the distance  $R$  between point  $P$  and the element.

Mathematically, the Biot-Savart law can be stated as,

$$d\vec{H} \propto \frac{I dL \sin \theta}{R^2} \quad \dots (1)$$

$$\therefore \boxed{d\vec{H} = \frac{k I dL \sin \theta}{R^2}} \quad \dots (2)$$

where  $k =$  Constant of proportionality

In SI units,  $k = \frac{1}{4\pi}$

$$\therefore d\vec{H} = \frac{I dL \sin \theta}{4\pi R^2} \quad \dots (3)$$

Let us express this equation in vector form.

Let  $dL =$  Magnitude of vector length  $d\vec{L}$  and

$\vec{a}_R =$  Unit vector in the direction from differential current element to point P

Then from rule of cross product,

$$d\vec{L} \times \vec{a}_R = dL |\vec{a}_R| \sin \theta = dL \sin \theta \quad \dots |\vec{a}_R| = 1$$

Replacing in equation (3),

$$d\vec{H} = \frac{I d\vec{L} \times \vec{a}_R}{4\pi R^2} \text{ A/m} \quad \dots (4)$$

But  $\vec{a}_R = \frac{\vec{R}}{|\vec{R}|} = \frac{\vec{R}}{R}$

Hence, 
$$\boxed{d\vec{H} = \frac{I d\vec{L} \times \vec{R}}{4\pi R^3} \text{ A/m}} \quad \dots (5)$$

The equations (4) and (5) is the mathematical form of Biot-Savart law.

According to the direction of cross product, the direction of  $d\vec{H}$  is normal to the plane containing two vectors and in that normal direction which is along the progress of right handed screw, turned from  $d\vec{L}$  through the smaller angle  $\theta$  towards the line joining element to the point P. Thus the direction of  $d\vec{H}$  is normal to the plane of paper. For the case considered, according to right handed screw rule, the direction of  $d\vec{H}$  is going into the plane of the paper.

The entire conductor is made up of all such differential elements. Hence to obtain total magnetic field intensity  $\vec{H}$ , the above equation (4) takes the integral form as,

$$\boxed{\vec{H} = \oint \frac{I d\vec{L} \times \vec{a}_R}{4\pi R^2}} \quad \dots (6)$$

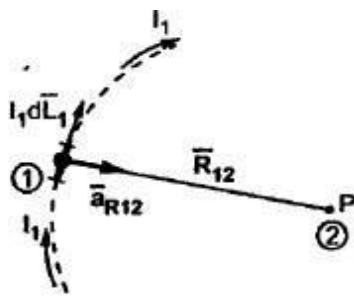


Fig. 7.7

The closed line integral is required to ensure that all the current elements are considered. This is because current can flow only in the closed path, provided by the closed circuit. If the current element is considered at point 1 and point P at point 2, as shown in the Fig. 7.7 then,

$$d\bar{H}_2 = \frac{I_1 d\bar{L}_1 \times \bar{a}_{R12}}{4\pi R_{12}^2} \text{ A/m} \quad \dots (7)$$

where

- $I_1$  = Current flowing through  $dL_1$  at point 1
- $dL_1$  = Differential vector length at point 1
- $\bar{a}_{R12}$  = Unit vector in the direction from element at point 1 to the point P at point 2

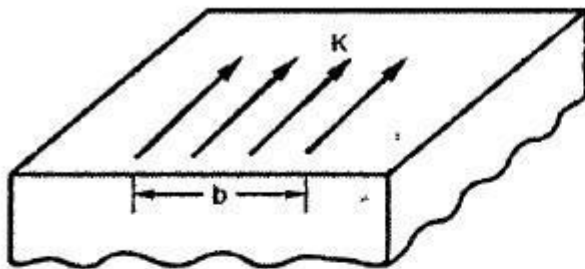
$$\bar{a}_{R12} = \frac{\bar{R}_{12}}{|\bar{R}_{12}|} = \frac{\bar{R}_{12}}{R_{12}}$$

$\therefore$

$$\bar{H}_2 = \oint \frac{I_1 d\bar{L}_1 \times \bar{a}_{R12}}{4\pi R_{12}^2} \text{ A/m} \quad \dots (8)$$

This is called **integral form of Biot-Savart law.**

### 7.3.1 Biot-Savart Law Intems of Distributed Sources



**Fig. 7.8 Surface current density**

Consider a surface carrying a uniform current over its surface as shown in the Fig. 7.8. Then the surface current density is denoted as  $\vec{K}$  and measured in amperes per metre (A/m). Thus for uniform current density, the current  $I$  in any width  $b$  is given by  $I = Kb$ , where width  $b$  is perpendicular to the direction of current flow.

Thus if  $dS$  is the differential surface area considered of a surface having current density  $\vec{K}$  then,

$$I d\vec{L} = \vec{K} dS \quad \dots (9)$$

If the current density in a volume of a given conductor is  $\vec{J}$  measured in  $A / m^2$  then for a differential volume  $dv$  we can write,

$$I d\vec{L} = \vec{J} dv \quad \dots (10)$$

Hence the Biot-Savart law can be expressed for surface current considering  $\vec{K} dS$  while for volume current considering  $\vec{J} dv$ .

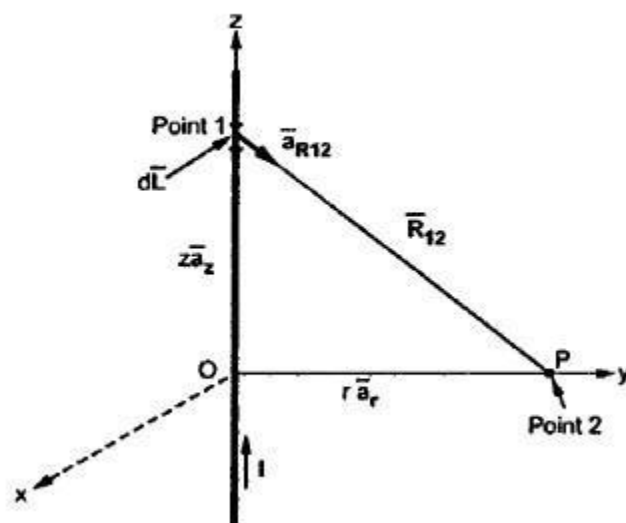
$$\therefore \vec{H} = \int_S \frac{\vec{K} \times \vec{a}_R dS}{4\pi R^2} \quad A/m \quad \dots (11)$$

and

$$\vec{H} = \int_{vol} \frac{\vec{J} \times \vec{a}_R dv}{4\pi R^2} \quad A/m \quad \dots (12)$$

The Biot-Savart law is also called Ampere's law for the current element. Let us study now the various applications of Biot-Savart law.

### 7.4 $\vec{H}$ due to Infinitely Long Straight Conductor



**Fig. 7.10  $\vec{H}$  due to infinitely long straight conductor**

Consider an infinitely long straight conductor, along  $z$ -axis. The current passing through the conductor is a direct current of  $I$  Amp. The field intensity  $\vec{H}$  at a point  $P$  is to be calculated, which is at a distance ' $r$ ' from the  $z$ -axis. This is shown in the Fig. 7.10.

Consider small differential element at point 1, along the  $z$ -axis, at a distance  $z$  from origin.

$$\therefore I d\vec{L} = I dz \vec{a}_z \quad \dots (1)$$

The distance vector joining point 1 to point 2 is  $\vec{R}_{12}$  and can be written as,

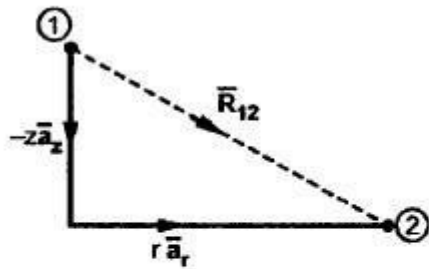


Fig. 7.11

$$\vec{R}_{12} = -z \vec{a}_z + r \vec{a}_r \quad \dots (2)$$

$$\vec{a}_{R12} = \frac{\vec{R}_{12}}{|\vec{R}_{12}|} = \frac{r \vec{a}_r - z \vec{a}_z}{\sqrt{r^2 + z^2}} \quad \dots (3)$$

$$\therefore d\vec{L} \times \vec{a}_{R12} = \begin{vmatrix} \vec{a}_r & \vec{a}_\phi & \vec{a}_z \\ 0 & 0 & dz \\ r & 0 & -z \end{vmatrix} = r dz \vec{a}_\phi$$

While obtaining cross product,  $|\vec{R}_{12}|$  is neglected for convenience and must be considered for further calculations.

$$\therefore I d\vec{L} \times \vec{a}_{R12} = \frac{I r dz \vec{a}_\phi}{\sqrt{r^2 + z^2}} \quad \dots (4)$$

According to Biot-Savart law,  $d\vec{H}$  at point 2 is,

$$\begin{aligned} d\vec{H} &= \frac{I d\vec{L} \times \vec{a}_{R12}}{4\pi R_{12}^2} = \frac{I r dz \vec{a}_\phi}{4\pi \sqrt{r^2 + z^2} (\sqrt{r^2 + z^2})^2} \\ &= \frac{I r dz \vec{a}_\phi}{4\pi (r^2 + z^2)^{3/2}} \quad \dots (5) \end{aligned}$$

Thus total field intensity  $\vec{H}$  can be obtained by integrating  $d\vec{H}$  over the entire length of the conductor.

$$\therefore \vec{H} = \int_{z=-\infty}^{\infty} d\vec{H} = \int_{z=-\infty}^{\infty} \frac{I r dz \vec{a}_\phi}{4\pi (r^2 + z^2)^{3/2}} \quad \dots (6)$$

Put  $z = r \tan \theta$ ,  $z^2 = r^2 \tan^2 \theta$

and  $dz = r \sec^2 \theta d\theta$ ,  $z = -\infty$ ,  $\theta = -\frac{\pi}{2}$  and  $z = +\infty$ ,  $\theta = +\frac{\pi}{2}$

$$\begin{aligned} \therefore \vec{H} &= \int_{\theta=-\pi/2}^{\pi/2} \frac{I r r \sec^2 \theta d\theta \vec{a}_\phi}{4\pi (r^2 + r^2 \tan^2 \theta)^{3/2}} \\ &= \int_{\theta=-\pi/2}^{\pi/2} \frac{I r^2 \sec^2 \theta d\theta \vec{a}_\phi}{4\pi r^3 \sec^3 \theta} \quad \dots 1 + \tan^2 \theta = \sec^2 \theta \\ &= \int_{\theta=-\pi/2}^{\pi/2} \frac{I}{4\pi r} \frac{1}{\sec \theta} d\theta \vec{a}_\phi = \frac{I}{4\pi r} \int_{\theta=-\pi/2}^{\pi/2} \cos \theta d\theta \vec{a}_\phi \end{aligned}$$

$$= \frac{I}{4\pi r} [\sin \theta]_{-\pi/2}^{\pi/2} \bar{a}_\phi = \frac{I}{4\pi r} \left[ \sin \frac{\pi}{2} - \sin \left( -\frac{\pi}{2} \right) \right] \bar{a}_\phi$$

$$= \frac{I}{4\pi r} [1 - (-1)] \bar{a}_\phi = \frac{2I}{4\pi r} \bar{a}_\phi \dots$$

$$\therefore \bar{H} = \frac{I}{2\pi r} \bar{a}_\phi \quad \text{A/m} \quad \dots (7)$$

$$\bar{B} = \mu \bar{H} = \frac{\mu I}{2\pi r} \bar{a}_\phi \quad \text{Wb/m}^2 \quad \dots (8)$$

The following observations are important about  $\bar{H}$  :

1. The magnitude of magnetic field intensity  $\bar{H}$  is not a function of  $\phi$  or  $z$ . It is inversely proportional to  $r$  which is the perpendicular distance of the point from the conductor.
2. The direction of  $\bar{H}$  is tangential i.e. circumferential along  $\bar{a}_\phi$ . This direction is going into the plane of the paper at point P.
3. The streamlines i.e. magnetic flux lines are in the form of concentric circles around the conductor. Thus if conductor is viewed from the top with  $I$  coming out of the paper towards observer, then the streamlines are anticlockwise.

## 7.6 $\bar{H}$ at the Centre of a Circular Conductor

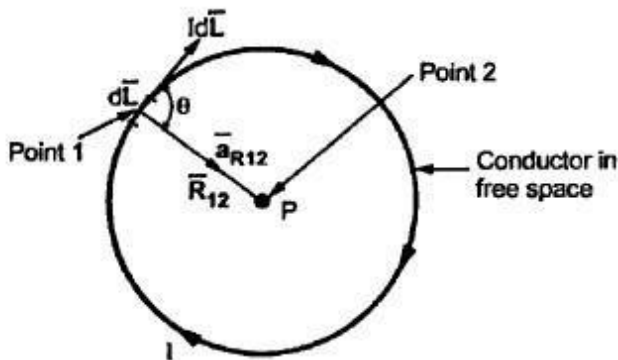


Fig. 7.15

Consider the current carrying conductor arranged in a circular form as shown in the Fig. 7.15.

The  $\bar{H}$  at the centre of the circular loop is to be obtained. The conductor carries the direct current  $I$ .

Consider the differential length  $d\bar{L}$  at a point 1.

The direction of  $d\bar{L}$  at a point 1 is tangential to the circular conductor at point 1.

- Let
- $\theta$  = Angle between  $I d\bar{L}$  and  $\bar{a}_{R12}$
  - $\bar{a}_{R12}$  = Unit vector in the direction of  $\bar{R}_{12}$
  - $\bar{R}_{12}$  = Distance vector joining differential current element at point 1 to point P at point 2 which is centre of circle.

Using the definition of cross product,

$$\therefore I d\bar{L} \times \bar{a}_{R12} = I |d\bar{L}| |\bar{a}_{R12}| \sin \theta \bar{a}_N = I dL \sin \theta \bar{a}_N \quad \dots (1)$$



$\bar{a}_N$  = Unit vector normal to the plane containing  $d\bar{L}$  and  $\bar{a}_{R12}$   
 i.e. normal to the plane in which the circular  
 conductor is lying

According to Biot-Savart law, the differential magnetic field intensity  $d\bar{H}$  at point P is,

$$d\bar{H} = \frac{I d\bar{L} \times \bar{a}_{R12}}{4\pi R_{12}^2} = \frac{I dL \sin \theta \bar{a}_N}{4\pi R^2} \quad \dots R = R_{12} = \text{Radius}$$

Hence total magnetic field intensity  $\bar{H}$  at point P can be obtained by integrating  $d\bar{H}$  around the circular closed path.

$$\therefore \bar{H} = \oint d\bar{H} = \oint \frac{I dL \sin \theta \bar{a}_N}{4\pi R^2} = \frac{I \sin \theta \bar{a}_N}{4\pi R^2} \oint dL \quad \dots (2)$$

But  $\oint dL =$  Circumference of the circle  $= 2\pi R$  ... (3)

$$\therefore \bar{H} = \frac{I \sin \theta 2\pi R \bar{a}_N}{4\pi R^2} = \frac{I \sin \theta}{2R} \bar{a}_N \quad \dots (4)$$

As  $I d\bar{L}$  is tangential to the circle and  $R_{12}$  is the radius, angle  $\theta$  must be  $90^\circ$ .

$$\therefore \bar{H} = \frac{I \sin 90^\circ}{2R} \bar{a}_N = \frac{I}{2R} \bar{a}_N \text{ A/m} \quad \dots (5)$$

$\bar{a}_N = \bar{a}_z$  if the circular loop is placed in xy plane

Now  $\bar{B} = \mu_0 \bar{H}$  ... for free space

The flux density  $\bar{B}$  at centre of the circular conductor carrying direct current I, placed in a free space is given by,

$$\bar{B} = \frac{\mu_0 I}{2R} \bar{a}_N \text{ Wb/m}^2 \quad \dots (6)$$

## 7.7 $\vec{H}$ on the Axis of a Circular Loop

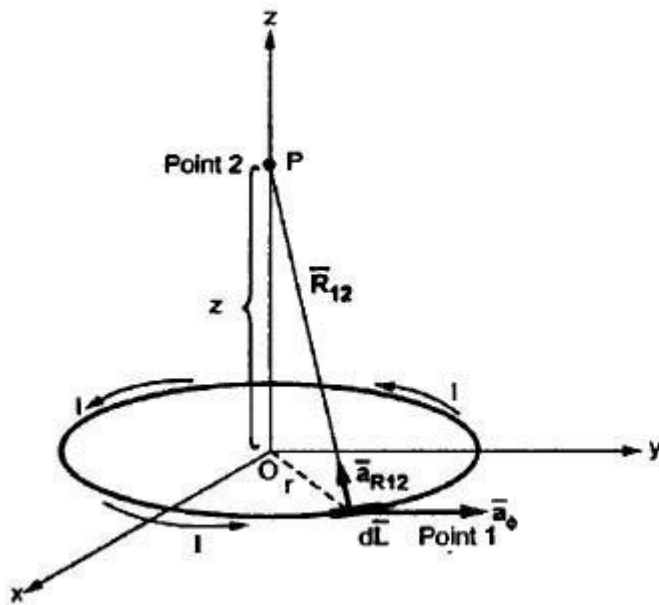


Fig. 7.16

But  $d\vec{L}$  is in the plane for which  $r$  is constant and  $z = 0 = \text{constant}$  plane. The  $I d\vec{L}$  is tangential at point 1 in  $\vec{a}_\phi$  direction.

$$\therefore I d\vec{L} = I r d\phi \vec{a}_\phi \quad \dots (1)$$

The unit vector  $\vec{a}_{R12}$  is in the direction along the line joining differential current element to the point P.

$$\therefore \vec{a}_{R12} = \frac{\vec{R}_{12}}{|\vec{R}_{12}|} \quad \dots (2)$$

From the Fig. 7.17, it can be observed that,

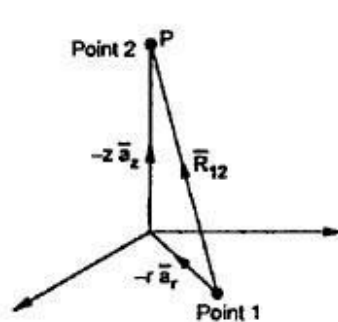


Fig. 7.17

$$\vec{R}_{12} = -r \vec{a}_r + z \vec{a}_z \quad \dots \text{from 1 to 2}$$

$$\therefore |\vec{R}_{12}| = \sqrt{(-r)^2 + (z)^2} = \sqrt{r^2 + z^2}$$

$$\therefore \vec{a}_{R12} = \frac{-r \vec{a}_r + z \vec{a}_z}{\sqrt{r^2 + z^2}} \quad \dots (3)$$

$$\text{Now } d\vec{L} \times \vec{a}_{R12} = \begin{vmatrix} \vec{a}_r & \vec{a}_\phi & \vec{a}_z \\ 0 & r d\phi & 0 \\ -r & 0 & z \end{vmatrix} = z r d\phi \vec{a}_r + r^2 d\phi \vec{a}_z$$

Note that while calculating cross product  $|\vec{R}_{12}|$  is neglected for convenience, which must be considered in further calculations.

Consider a circular loop carrying a direct current  $I$ , placed in  $xy$  plane, with  $z$ -axis as its axis as shown in the Fig. 7.16. The magnetic field intensity  $\vec{H}$  at point P is to be obtained. The point P is at a distance  $z$  from the plane of the circular loop, along its axis.

The radius of the circular loop is  $r$ . Consider the differential length  $d\vec{L}$  of the circular loop as shown in the Fig. 7.16.

In the cylindrical co-ordinate system,

$$d\vec{L} = dr \vec{a}_r + r d\phi \vec{a}_\phi + dz \vec{a}_z$$

According to Biot-Savart law, the differential field strength  $d\bar{H}$  at point P is given by,

$$d\bar{H} = \frac{I d\bar{L} \times \bar{a}_{R12}}{4\pi R_{12}^2} = \frac{I [z r d\phi \bar{a}_r + r^2 d\phi \bar{a}_z]}{4\pi \sqrt{r^2 + z^2} (\sqrt{r^2 + z^2})^2} \quad \dots (4)$$

Note that  $|\bar{R}_{12}|$  neglected while obtaining the cross product is considered in  $d\bar{H}$ .

The total  $\bar{H}$  is to be obtained by integrating  $d\bar{H}$  over the circular loop i.e. for  $\phi=0$  to  $2\pi$ .

**Note :** It can be observed that though  $d\bar{H}$  consists of two components  $\bar{a}_r$  and  $\bar{a}_z$ , due to radial symmetry all  $\bar{a}_r$  components are going to cancel each other. So  $\bar{H}$  exists only along the axis in  $\bar{a}_z$  direction. Let us prove this mathematically.

$$\bar{H} = \int_{\phi=0}^{2\pi} \frac{I [z r \bar{a}_r + r^2 \bar{a}_z] d\phi}{4\pi (r^2 + z^2)^{3/2}} \quad \dots (5)$$

$$= \frac{I}{4\pi} \left\{ \int_{\phi=0}^{2\pi} \frac{z r d\phi}{(r^2 + z^2)^{3/2}} \bar{a}_r + \int_{\phi=0}^{2\pi} \frac{r^2 \bar{a}_z d\phi}{(r^2 + z^2)^{3/2}} \right\} \quad \dots (6)$$

Consider first integral to prove that its value is zero due to radial symmetry.

$$\int_{\phi=0}^{2\pi} \frac{z r d\phi}{(r^2 + z^2)^{3/2}} \bar{a}_r = \int_{\phi=0}^{2\pi} \frac{z r d\phi}{(r^2 + z^2)^{3/2}} [\cos \phi \bar{a}_x + \sin \phi \bar{a}_y]$$

The unit vector  $\bar{a}_r$  is expressed in rectangular co-ordinate system as

$$\cos \phi \bar{a}_x + \sin \phi \bar{a}_y.$$

$$\text{Now } \int_{\phi=0}^{2\pi} \cos \phi d\phi = [\sin \phi]_{\phi=0}^{2\pi} = \sin 2\pi - \sin 0 = 0$$

$$\text{And } \int_{\phi=0}^{2\pi} \sin \phi d\phi = [-\cos \phi]_{\phi=0}^{2\pi} = -\cos 2\pi - [-\cos 0] = -1 + 1 = 0$$

$$\therefore \int_{\phi=0}^{2\pi} \frac{z r d\phi}{(r^2 + z^2)^{3/2}} \bar{a}_r = 0$$

This proves that  $\bar{H}$  at P can not have any radial component.

$$\begin{aligned} \therefore \bar{H} &= \frac{I}{4\pi} \int_{\phi=0}^{2\pi} \frac{r^2 d\phi}{(r^2 + z^2)^{3/2}} \bar{a}_z = \frac{I r^2 \bar{a}_z}{4\pi (r^2 + z^2)^{3/2}} \int_{\phi=0}^{2\pi} d\phi \\ &= \frac{I r^2 \bar{a}_z [\phi]_{\phi=0}^{2\pi}}{4\pi (r^2 + z^2)^{3/2}} = \frac{I r^2 2\pi \bar{a}_z}{4\pi (r^2 + z^2)^{3/2}} \end{aligned}$$

$$\therefore \quad \vec{H} = \frac{I r^2}{2(r^2 + z^2)^{3/2}} \vec{a}_z \quad \text{A/m} \quad \dots (7)$$

where  $r$  = Radius of the circular loop  
 $z$  = Distance of point P along the axis

**Note :** If point P is shifted at the centre of the circular loop i.e.  $z = 0$ , we get the result obtained in earlier section.

$$\vec{H} = \frac{I r^2}{2(r^2)^{3/2}} \vec{a}_z = \frac{I}{2r} \vec{a}_z \quad \text{A/m}$$

where  $\vec{a}_z$  is the unit vector normal to xy plane in which the circular loop is lying.

## 7.8 Ampere's Circuital Law

In electrostatics, the Gauss's law is useful to obtain the  $\vec{E}$  in case of complex problems. Similarly in the magnetostatics, the complex problems can be solved using a law called **Ampere's circuital law** or **Ampere's work law**.

The Ampere's circuital law states that,

The line integral of magnetic field intensity  $\vec{H}$  around a closed path is exactly equal to the direct current enclosed by that path.

The mathematical representation of Ampere's circuital law is,

$$\oint \vec{H} \cdot d\vec{L} = I \quad \dots (1)$$

The law is very helpful to determine  $\vec{H}$  when the current distribution is symmetrical.

### 7.8.1 Proof of Ampere's Circuital Law

Consider a long straight conductor carrying direct current  $I$  placed along  $z$  axis as shown in the Fig. 7.26. Consider a closed circular path of radius  $r$  which encloses the straight conductor carrying direct current  $I$ . The point P is at a perpendicular distance  $r$  from the conductor. Consider  $d\vec{L}$  at point P which is in  $\vec{a}_\phi$  direction, tangential to circular path at point P.

$$\therefore \quad d\vec{L} = r \, d\phi \, \vec{a}_\phi \quad \dots (2)$$

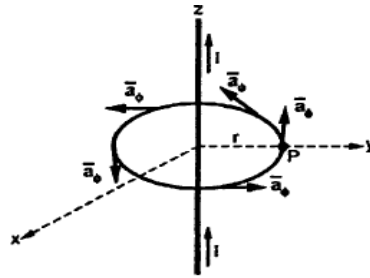


Fig. 7.26

While  $\vec{H}$  obtained at point P, from Biot-Savart law due to infinitely long conductor is,

$$\vec{H} = \frac{I}{2\pi r} \vec{a}_\phi \quad \dots (3)$$

$$\therefore \vec{H} \cdot d\vec{L} = \frac{I}{2\pi r} \vec{a}_\phi \cdot r d\phi \vec{a}_\phi$$

$$= \frac{I}{2\pi r} r d\phi = \frac{I}{2\pi} d\phi \quad \dots \vec{a}_\phi \cdot \vec{a}_\phi = 1$$

Integrating  $\vec{H} \cdot d\vec{L}$  over the entire closed path,

$$\int \vec{H} \cdot d\vec{L} = \int_{\phi=0}^{2\pi} \frac{I}{2\pi} d\phi = \frac{I}{2\pi} [\phi]_0^{2\pi} = \frac{I 2\pi}{2\pi}$$

$$= I = \text{Current carried by conductor}$$

This proves that the integral  $\vec{H} \cdot d\vec{L}$  along the closed path gives the direct current enclosed by that closed path.

## 7.9 Applications of Ampere's Circuital Law

Let us study the various cases and the application of Ampere's circuital law to obtain  $\vec{H}$ .

### 7.9.1 $\vec{H}$ due to Infinitely Long Straight Conductor

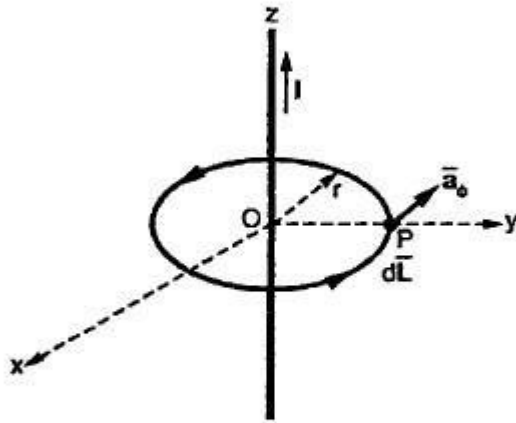


Fig. 7.27

Consider an infinitely long straight conductor placed along z-axis, carrying a direct current  $I$  as shown in the Fig. 7.27. Consider the Amperian closed path, enclosing the conductor as shown in the Fig. 7.27. Consider point  $P$  on the closed path at which  $\vec{H}$  is to be obtained. The radius of the path is  $r$  and hence  $P$  is at a perpendicular distance  $r$  from the conductor.

The magnitude of  $\vec{H}$  depends on  $r$  and the direction is always tangential to the closed path i.e.  $\vec{a}_\phi$ . So  $\vec{H}$  has only component in  $\vec{a}_\phi$  direction say  $H_\phi$ .

Consider elementary length  $d\vec{L}$  at point  $P$  and in cylindrical co-ordinates it is  $r d\phi$  in  $\vec{a}_\phi$  direction.

$$\therefore \vec{H} = H_\phi \vec{a}_\phi \quad \text{and} \quad d\vec{L} = r d\phi \vec{a}_\phi$$

$$\therefore \vec{H} \cdot d\vec{L} = H_\phi \vec{a}_\phi \cdot r d\phi \vec{a}_\phi = H_\phi r d\phi$$

According to Ampere's circuital law,

$$\oint \vec{H} \cdot d\vec{L} = I$$

$$\therefore \int_{\phi=0}^{2\pi} H_\phi r d\phi = I$$

$$\therefore H_\phi r \int_{\phi=0}^{2\pi} d\phi = I$$

$$\therefore H_\phi r (2\pi) = I$$

$$\therefore H_\phi = \frac{I}{2\pi r}$$

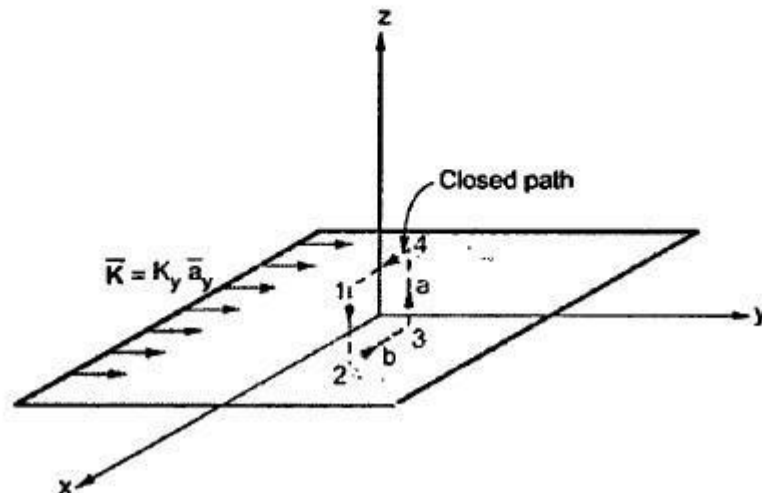
Hence  $\vec{H}$  at point  $P$  is given by,

$$\boxed{\vec{H} = H_\phi \vec{a}_\phi = \frac{I}{2\pi r} \vec{a}_\phi \text{ A/m}}$$

### 7.9.3 $\vec{H}$ due to Infinite Sheet of Current

Consider an infinite sheet of current in the  $z = 0$  plane. The surface current density is  $\vec{K}$ . The current is flowing in positive  $y$  direction hence  $\vec{K} = K_y \vec{a}_y$ . This is shown in the Fig. 7.32.

Consider a closed path 1-2-3-4 as shown in the Fig. 7.32. The width of the path is  $b$  while the height is  $a$ . It is perpendicular to the direction of current hence in  $xz$  plane.



The current flowing across the distance  $b$  is given by  $K_y b$ .

$$\therefore I_{enc} = K_y b \quad \dots (6)$$

Consider the magnetic lines of force due to the current in  $\vec{a}_y$  direction, according to right hand thumb rule. These are shown in the Fig. 7.33.

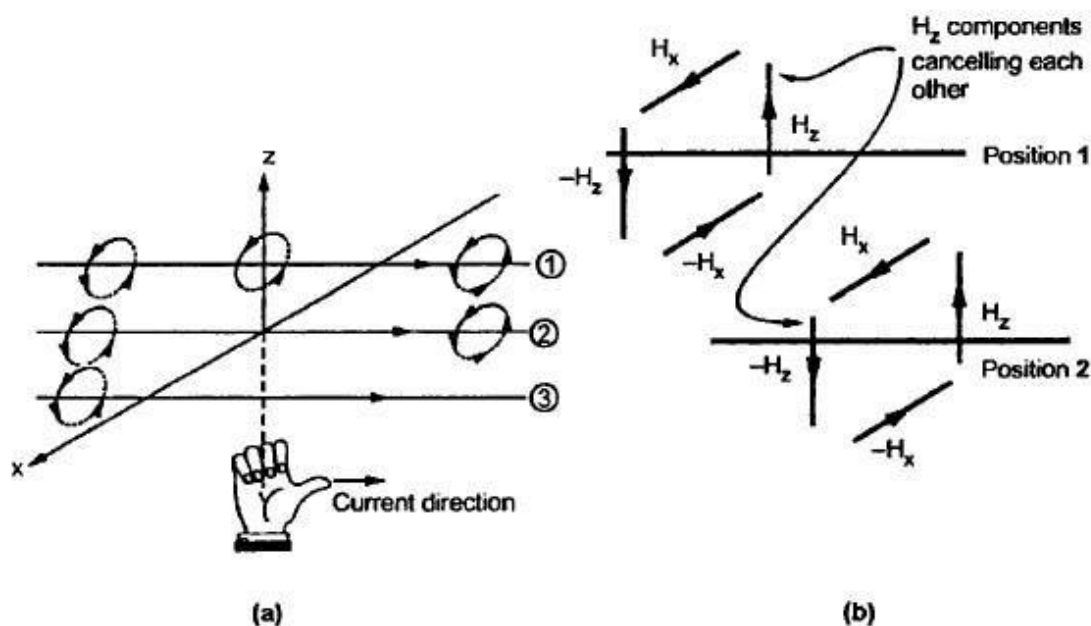


Fig. 7.33

In Fig. 7.33 (b), it is clear that in between two very closely spaced conductors, the components of  $\vec{H}$  in  $z$  direction are oppositely directed ( $-H_x$  for position 1 and  $+H_x$  for position 2 between the two positions). All such components cancel each other and hence  $\vec{H}$  can not have any component in  $z$  direction.

As current is flowing in  $y$  direction,  $\vec{H}$  can not have component in  $y$  direction.

So  $\vec{H}$  has only component in  $x$  direction.

$$\therefore \vec{H} = H_x \vec{a}_x \quad \dots \text{ for } z > 0 \quad \dots (7 \text{ (a)})$$

$$= -H_x \vec{a}_x \quad \dots \text{ for } z < 0 \quad \dots (7 \text{ (b)})$$

Applying Ampere's circuit law,

$$\oint \vec{H} \cdot d\vec{L} = I_{enc} \quad \dots (8)$$

Evaluate the integral along the path 1-2-3-4-1.

For path 1-2,  $d\vec{L} = dz \vec{a}_z$ ,

For path 3-4,  $d\vec{L} = dz \vec{a}_z$

But  $\vec{H}$  is in  $x$  direction while  $\vec{a}_x \cdot \vec{a}_z = 0$ .

Hence along the paths 1-2 and 3-4, the integral  $\oint \vec{H} \cdot d\vec{L} = 0$ .

Consider path 2-3 along which  $d\vec{L} = dx \vec{a}_x$ .

$$\therefore \int_2^3 \vec{H} \cdot d\vec{L} = \int_2^3 (-H_x \vec{a}_x) \cdot (dx \vec{a}_x) = -H_x \int_2^3 dx = -b H_x$$

The path 2-3 is lying in  $z < 0$  region for which  $\vec{H}$  is  $-H_x \vec{a}_x$ . And limits from 2 to 3, positive  $x$  to negative  $x$  hence effective sign of the integral is positive.

Consider path 4-1 along which  $d\vec{L} = dx \vec{a}_x$  and it is in the region  $z > 0$  hence  $\vec{H} = H_x \vec{a}_x$ .

$$\therefore \int_4^1 \vec{H} \cdot d\vec{L} = \int_4^1 (H_x \vec{a}_x) \cdot (dx \vec{a}_x) = H_x \int_4^1 dx = b H_x$$

$$\therefore \oint \vec{H} \cdot d\vec{L} = b H_x + b H_x = 2 b H_x \quad \dots (9)$$

Equating this to  $I_{enc}$  in equation (6),

$$2 b H_x = K_y b$$

$$\therefore H_x = \frac{1}{2} K_y \quad \dots (10)$$

$$\text{Hence, } \vec{H} = \frac{1}{2} K_y \vec{a}_x \quad \text{for } z > 0 \quad \dots (11 \text{ (a)})$$

$$= -\frac{1}{2} K_y \vec{a}_x \quad \text{for } z < 0 \quad \dots (11 \text{ (b)})$$



In general, for an infinite sheet of current density  $\bar{K}$  A/m we can write,

$$\bar{H} = \frac{1}{2} \bar{K} \times \bar{a}_N \quad \dots (12)$$

where  $\bar{a}_N$  = Unit vector normal from the current sheet to the point  
at which  $\bar{H}$  is to be obtained.

## 8.2 Force on a Moving Point Charge

According to the discussion in the previous chapters, a static electric field  $\bar{E}$  exerts a force on a static or moving charge  $Q$ . Thus according to Coulomb's law, the force  $\bar{F}_e$  exerted on an electric charge can be obtained. The force is related to the electric field intensity  $\bar{E}$  as,

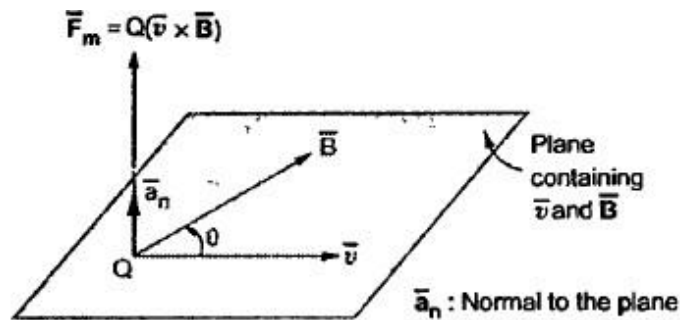
$$\bar{F}_e = Q \bar{E} \text{ N} \quad \dots (1)$$

For a positive charge, the force exerted on it is in the direction of  $\bar{E}$ . This force is also referred as **electric force** ( $\bar{F}_e$ ).

Now consider that a charge is placed in a steady magnetic field. It experiences a force only if it is moving. Then a **magnetic force** ( $\bar{F}_m$ ) exerted on a charge  $Q$ , moving with a velocity  $\bar{v}$  in a steady magnetic field  $\bar{B}$  is given by,

$$\bar{F}_m = Q \bar{v} \times \bar{B} \text{ N} \quad \dots (2)$$

The magnitude of the magnetic force  $\bar{F}_m$  is directly proportional to the magnitudes of  $Q$ ,  $\bar{v}$  and  $\bar{B}$  and also the sine of the angle between  $\bar{v}$  and  $\bar{B}$ . The direction of  $\bar{F}_m$  is perpendicular to the plane containing  $\bar{v}$  and  $\bar{B}$  both, as shown in the Fig. 8.1.



**Fig. 8.1 Magnetic force on a moving charge in magnetic field**

From equation (1) it is clear that the electric force  $\bar{F}_e$  is independent of the velocity of the moving charge. In other words, the electric force exerted on the moving charge by the electric field is independent of the direction in which the charge is moving. Thus the electric force performs work on the charge. On the other hand, the magnetic force  $\bar{F}_m$  is dependent on the velocity of the moving charge. But  $\bar{F}_m$  cannot perform work on a moving charge as it is at right angle to the direction of motion of charge. ( $\bar{F} \cdot d\bar{L} = 0$ ).

The total force on a moving charge in the presence of both electric and magnetic fields is given by,

$$\boxed{F = \bar{F}_e + \bar{F}_m = Q (\bar{E} + \bar{v} \times \bar{B}) \text{ N}} \quad \dots (3)$$

Above equation is called **Lorentz Force Equation** which relates mechanical force to the electrical force. If the mass of the charge is  $m$ , then we can write,

$$\boxed{\bar{F} = m \bar{a} = m \frac{d\bar{v}}{dt} = Q (\bar{E} + \bar{v} \times \bar{B}) \text{ N}} \quad \dots (4)$$

### 8.3 Force on a Differential Current Element

The force exerted on a differential element of charge  $dQ$  moving in a steady magnetic field is given by,

$$d\bar{F} = dQ \bar{v} \times \bar{B} \text{ N} \quad \dots (1)$$

The current density  $\bar{J}$  can be expressed in terms of velocity of a volume charge density as,

$$\bar{J} = \rho_v \bar{v} \quad \dots (2)$$

But the differential element of charge can be expressed in terms of the volume charge density as,

$$dQ = \rho_v dv \quad \dots (3)$$

Substituting value of  $dQ$  in equation (1),

$$\therefore d\vec{F} = \rho_v dv \vec{v} \times \vec{B}$$

Expressing  $d\vec{F}$  in terms of  $\vec{J}$  using equation (2), we can write,

$$d\vec{F} = \vec{J} \times \vec{B} dv \quad \dots (4)$$

But we have already studied in previous chapters, the relationship between current element as,

$$\vec{J} dv = \vec{K} dS = I d\vec{L}$$

Then the force exerted on a surface current density is given by,

$$d\vec{F} = \vec{K} \times \vec{B} dS \quad \dots (5)$$

Similarly the force exerted on a differential current element is given by,

$$d\vec{F} = (I d\vec{L} \times \vec{B}) \quad \dots (6)$$

Integrating equation (4) over a volume, the force is given by,

$$\vec{F} = \int_{vol} \vec{J} \times \vec{B} dv \quad \dots (7)$$

Integrating equation (5) over either open or closed surface, we get,

$$\vec{F} = \int_s \vec{K} \times \vec{B} dS \quad \dots (8)$$

Similarly integrating equation (6) over a closed path, we get,

$$\vec{F} = \oint I d\vec{L} \times \vec{B} \quad \dots (9)$$

If a conductor is straight and the field  $\vec{B}$  is uniform along it, then integrating equation (6) we get simple expression for the force as,

$$\vec{F} = I \vec{L} \times \vec{B} \quad \dots (10)$$

The magnitude of the force is given by,

$$F = I L B \sin \theta \quad \dots (11)$$

Actually the magnetic field exerts a magnetic force on the electrons which constitutes the current  $I$ . But these electrons are part of the conductor, this magnetic force gets transferred to the conductor lattice. Now this transferred force can perform work on a conductor as a whole.

## 8.4 Force between Differential Current Elements

While discussing the electrostatic fields, we have studied that a point charge exerts force on another point charge, separated by distance  $R$ . If these charges are of same type (i.e. both positive or negative), then they repel each other. But when two charges are of different type (i.e. one positive and other negative), then they attract each other.

Now consider that two current carrying conductors are placed parallel to each other. Each of this conductor produces its own flux around it. So when such two conductors are placed closed to each other, there exists a force due to the interaction of two fluxes. The force between such parallel current carrying conductors depends on the directions of the two currents. If the directions of both the currents are same, then the conductors experience a force of attraction as shown in the Fig. 8.2 (a). And if the directions of two currents are opposite to each other, then the conductors experience a force of repulsion as shown in the Fig. 8.2 (b).

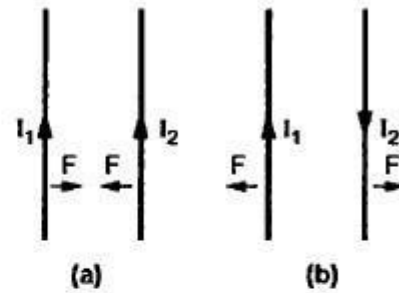


Fig. 8.2 Force between two parallel current carrying conductors

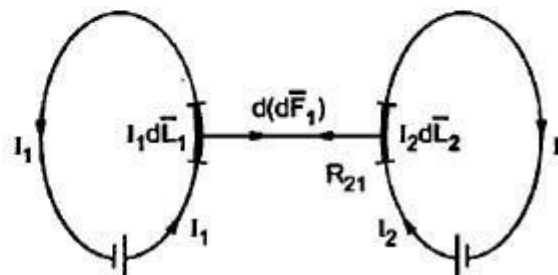


Fig. 8.3 Force between two current elements

Let us now consider two current elements  $I_1 d\vec{L}_1$  and  $I_2 d\vec{L}_2$  as shown in the Fig. 8.3. Note that the directions of  $I_1$  and  $I_2$  are same.

Both the current elements produce their own magnetic fields. As the currents are flowing in the same direction through the elements, the force  $d(d\vec{F}_1)$  exerted on element  $I_1 d\vec{L}_1$  due to the magnetic field  $d\vec{B}_2$  produced by other element  $I_2 d\vec{L}_2$  is the force of attraction.

From the equation of force the force exerted on a differential current element is given by,

$$d(d\vec{F}_1) = I_1 d\vec{L}_1 \times d\vec{B}_2 \quad \dots (1)$$

According to Biot-Savart's law, the magnetic field produced by current element  $I_2 d\vec{L}_2$  is given by, for free space,

$$d\vec{B}_2 = \mu_0 d\vec{H}_2 = \mu_0 \left[ \frac{I_2 d\vec{L}_2 \times \vec{a}_{R21}}{4\pi R_{21}^2} \right] \quad \dots (2)$$

Substituting value of  $d\vec{B}_2$  in equation (1), we can write,

$$d(d\vec{F}_1) = \mu_0 \frac{I_1 d\vec{L}_1 \times (I_2 d\vec{L}_2 \times \vec{a}_{R21})}{4\pi R_{21}^2} \quad \dots (3)$$

The equation (3) represents force between two current elements. It is very much similar to Coulomb's law. By integrating  $d(d\vec{F}_1)$  twice, the total force  $\vec{F}_1$  on current element 1 due to current element 2 is given by,

$$\vec{F}_1 = \frac{\mu_0 I_1 I_2}{4\pi} \oint_{L_1} \oint_{L_2} \frac{d\vec{L}_1 \times (d\vec{L}_2 \times \vec{a}_{R21})}{R_{21}^2} \quad \dots (4)$$

Exactly following same steps, we can calculate the force  $\vec{F}_2$  exerted on the current element 2 due to the magnetic field  $\vec{B}_1$  produced by the current element 1. Thus,

$$\vec{F}_2 = \frac{\mu_0 I_2 I_1}{4\pi} \oint_{L_2} \oint_{L_1} \frac{d\vec{L}_2 \times (d\vec{L}_1 \times \vec{a}_{R12})}{R_{12}^2} \quad \dots (5)$$

Actually equation (5) is obtained from equation (4) by interchanging the subscripts 1 and 2. By using back-cab rule for expanding vector triple product, we can show that

$$\vec{F}_2 = -\vec{F}_1 \quad \dots (6)$$

Thus, above condition indicates that both the forces  $\vec{F}_1$  and  $\vec{F}_2$  obey Newton's third law that for every action there is equal and opposite reaction.

For the two current carrying conductors of length  $l$  each, the force exerted is given by

$$F = \frac{\mu I_1 I_2 l}{2\pi d} \quad \dots (7)$$

where  $I_1$  and  $I_2$  are the currents flowing through conductor 1 and conductor 2 and  $d$  is the distance of separation between two conductors.

If the two currents flow in same directions, the current carrying conductors attract each other. While if, the two currents flow in opposite direction to each other, the current carrying conductors repel each other.

## 8.5.2 Magnetic Dipole Moment

The magnetic dipole moment of a current loop is defined as the product of current through the loop and the area of the loop, directed normal to the current loop. From the definition it is clear that, the magnetic dipole moment is a vector quantity. It is denoted by  $\vec{m}$ . The direction of the magnetic dipole moment  $\vec{m}$  is given by the right hand thumb rule. The right hand thumb indicates the direction of the unit vector in which  $\vec{m}$  is directed and the fingers represents the current direction. The magnetic dipole moment is given by

$$\vec{m} = (IS)\vec{a}_n \text{ A}\cdot\text{m}^2 \quad \dots (12)$$

In the previous section we have obtained the expression for the torque along the axis of rotation of a planar coil as,

$$\vec{T} = BIS(-\vec{a}_y)$$

Using definition for the magnetic dipole moment, the torque can be expressed as,

$$\vec{T} = \vec{m} \times \vec{B} \text{ Nm} \quad \dots (13)$$

Above expression is in general applicable in calculating the overall torque on a planar loop of any arbitrary shape. But the basic requirement is that the magnetic field must be uniform. The torque is always in the direction of axis of rotation. When the planar loop or coil is normal to the magnetic field, the sum of the forces on the planar loop as well as the torque will be zero.

## 8.8 Magnetic Boundary Conditions

The conditions of the magnetic field existing at the boundary of the two media when the magnetic field passes from one medium to other are called **boundary conditions** for magnetic fields or simply **magnetic boundary conditions**. When we consider magnetic boundary conditions, the conditions of  $\vec{B}$  and  $\vec{H}$  are studied at the boundary. The boundary between the two different magnetic materials is considered. To study conditions of  $\vec{B}$  and  $\vec{H}$  at the boundary, both the vectors are resolved into two components ;

- a) Tangential to boundary and
- b) Normal (perpendicular) to boundary.

Consider a boundary between two isotropic, homogeneous linear materials with different permeabilities  $\mu_1$  and  $\mu_2$  as shown in the Fig. 8.14. To determine the boundary conditions, let us use the closed path and the Gaussian surface.

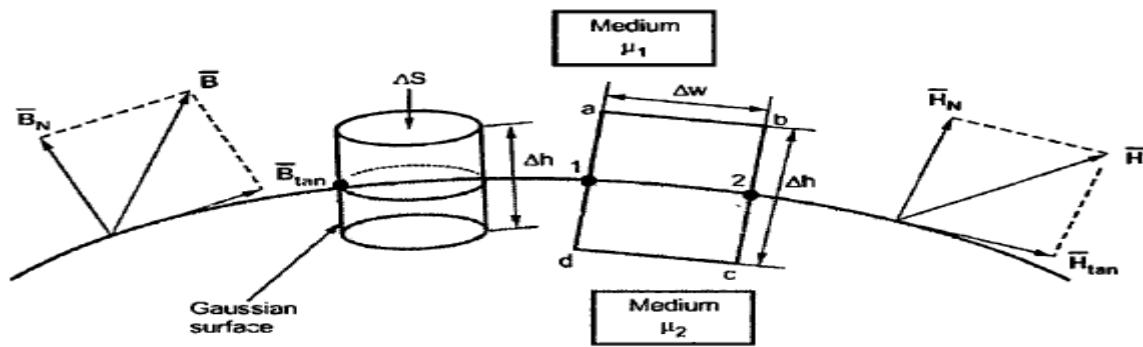


Fig. 8.14 Boundary between two magnetic materials of different permeabilities

### 8.8.1 Boundary Conditions for Normal Component

To find the normal component of  $\vec{B}$ , select a closed Gaussian surface in the form of a right circular cylinder as shown in the Fig. 8.14. Let the height of the cylinder be  $\Delta h$  and be placed in such a way that  $\Delta h/2$  is in medium 1 and remaining  $\Delta h/2$  is in medium 2. Also the axis of the cylinder is in the normal direction to the surface.

According to the Gauss's law for the magnetic field,

$$\oint_S \vec{B} \cdot d\vec{S} = 0 \quad \dots (1)$$

The surface integral must be evaluated over three surfaces, (i) Top, (ii) Bottom and (iii) Lateral.

Let the area of the top and bottom is same, equal to  $\Delta S$ .

$$\therefore \oint_{\text{top}} \vec{B} \cdot d\vec{S} + \oint_{\text{bottom}} \vec{B} \cdot d\vec{S} + \oint_{\text{lateral}} \vec{B} \cdot d\vec{S} = 0 \quad \dots (2)$$

As we are very much interested in the boundary conditions, reduce  $\Delta h$  to zero. As  $\Delta h \rightarrow 0$ , the cylinder tends to boundary and only top and bottom surfaces contribute in the surface integral. Thus surface integrals are calculated for top and bottom surfaces only. These surfaces are very small. Let the magnitude of normal component of  $\vec{B}$  be  $B_{N1}$  and  $B_{N2}$  in medium 1 and medium 2 respectively. As both the surfaces are very small, we can assume  $B_{N1}$  and  $B_{N2}$  constant over their surfaces. Hence we can write,

For top surfaces :

$$\oint_{\text{Top}} \vec{B} \cdot d\vec{S} = B_{N1} \oint_{\text{Top}} d\vec{S} = B_{N1} \Delta S \quad \dots (3)$$

For bottom surface :

$$\oint_{\text{Bottom}} \vec{B} \cdot d\vec{S} = B_{N2} \oint_{\text{Bottom}} d\vec{S} = B_{N2} \Delta S \quad \dots (4)$$

For lateral surface

$$\oint_{\text{Lateral}} \vec{B} \cdot d\vec{S} = 0 \quad \dots (5)$$

Putting values of surface integrals in equation (2), we get

$$B_{N_1} \Delta S - B_{N_2} \Delta S = 0 \quad \dots (6)$$

Note that the negative sign is used for one of the surface integrals because normal component in medium 2 is entering the surface while in medium 1 the component is leaving the surface. Hence  $B_{N_1}$  and  $B_{N_2}$  are in opposite direction.

From equation (6), we can write,

$$\begin{aligned} B_{N_1} \Delta S &= B_{N_2} \Delta S \\ \text{i.e. } \boxed{B_{N_1} &= B_{N_2}} \end{aligned} \quad \dots (7)$$

Thus the normal component of  $\vec{B}$  is continuous at the boundary.

As the magnetic flux density and the magnetic field intensity are related by

$$\vec{B} = \mu \vec{H}$$

Thus, equation (7) can be written as,

$$\begin{aligned} \mu_1 H_{N_1} &= \mu_2 H_{N_2} \\ \therefore \boxed{\frac{H_{N_1}}{H_{N_2}} &= \frac{\mu_2}{\mu_1} = \frac{\mu_{r2}}{\mu_{r1}}} \end{aligned} \quad \dots (8)$$

Hence the normal component of  $\vec{H}$  is not continuous at the boundary. The field strengths in two media are inversely proportional to their relative permeabilities.

### 8.8.2 Boundary Conditions for Tangential Component

According to Ampere's circuital law,

$$\oint \vec{H} \cdot d\vec{L} = I \quad \dots (9)$$

Consider a rectangular closed path  $abcd$  as shown in the Fig. 8.13. It is traced in clockwise direction as  $a-b-c-d-a$ . This closed path is placed in a plane normal to the boundary surface. Hence  $\oint \vec{H} \cdot d\vec{L}$  can be divided into 6 parts.

$$\oint \vec{H} \cdot d\vec{L} = \int_a^b \vec{H} \cdot d\vec{L} + \int_b^c \vec{H} \cdot d\vec{L} + \int_c^d \vec{H} \cdot d\vec{L} + \int_d^a \vec{H} \cdot d\vec{L} + \int_a^b \vec{H} \cdot d\vec{L} + \int_b^c \vec{H} \cdot d\vec{L} = I \quad \dots (10)$$



From the Fig. 8.14 it is clear that, the closed path is placed in such a way that its two sides a-b and e-d are parallel to the tangential direction to the surface while the other two sides are normal to the surface at the boundary. This closed path is placed in such a way that half of its portion is in medium 1 and the remaining is in medium 2. The rectangular path is an elementary rectangular path with elementary height  $\Delta h$  and elementary width  $\Delta w$ . Thus over small width  $\Delta w$ ,  $\bar{H}$  can be assume constant say  $H_{tan1}$  in medium 1 and  $H_{tan2}$  in medium 2. Similarly over a small height  $\frac{\Delta h}{2}$ ,  $\bar{H}$  can be assumed constant say  $H_{N1}$  in medium 1 and  $H_{N2}$  in medium 2. Now assume that  $\bar{K}$  is the surface current normal to the path. Also from the Fig. 8.14 it is clear that the normal and tangential components in medium 1 and medium 2 are in opposite direction. Thus equation (10) can be written as,

$$\begin{aligned} K \cdot dw = & H_{tan1}(\Delta w) + H_{N1}\left(\frac{\Delta h}{2}\right) + H_{N2}\left(\frac{\Delta h}{2}\right) - H_{tan2}(\Delta w) \\ & - H_{N2}\left(\frac{\Delta h}{2}\right) - H_{N1}\left(\frac{\Delta h}{2}\right) \end{aligned} \quad \dots (11)$$

To get conditions at boundary,  $\Delta h \rightarrow 0$ . Thus,

$$\begin{aligned} K \cdot dw = & H_{tan1}(\Delta w) - H_{tan2}(\Delta w) \\ H_{tan1} - H_{tan2} = & K \end{aligned} \quad \dots (12)$$

In vector form, we can express above relation by a cross product as

$$\boxed{\bar{H}_{\tan 1} - \bar{H}_{\tan 2} = \bar{a}_{N12} \times \bar{K}} \quad \dots (13)$$

where  $\bar{a}_{N12}$  is the unit vector in the direction normal at the boundary from medium 1 to medium 2.

For  $\bar{B}$ , the tangential components can be related with permeabilities of two media using equation (12),

$$\therefore \frac{B_{\tan 1}}{\mu_1} - \frac{B_{\tan 2}}{\mu_2} = K \quad \dots (14)$$

Consider a special case that the boundary is free of current. In other words, media are not conductors; so  $K = 0$ . Then equation (12) becomes

$$H_{\tan 1} - H_{\tan 2} = 0$$

$$\text{or} \quad H_{\tan 1} = H_{\tan 2} \quad \dots (15)$$

For tangential components of  $\bar{B}$  we can write,

$$\frac{B_{\tan 1}}{\mu_1} - \frac{B_{\tan 2}}{\mu_2} = 0$$

$$\therefore \frac{B_{\tan 1}}{\mu_1} = \frac{B_{\tan 2}}{\mu_2}$$

$$\therefore \boxed{\frac{B_{\tan 1}}{B_{\tan 2}} = \frac{\mu_1}{\mu_2} = \frac{\mu_{r1}}{\mu_{r2}}} \quad \dots (16)$$

From equations (15) and (16) it is clear that tangential component of  $\bar{H}$  are continuous, while tangential component of  $\bar{B}$  are discontinuous at the boundary, with the condition that the boundary is current free.

Let the fields make angles  $\alpha_1$  and  $\alpha_2$  with the normal to the interface as shown in the Fig. 8.15.

In terms of angle  $\alpha_1$  and  $\alpha_2$ , we can write relationship between normal components and tangential components of  $\bar{B}$ .

In medium 1,

$$\tan \alpha_1 = \frac{B_{\tan 1}}{B_{N1}} \quad \dots (17)$$

Similarly in medium 2,

$$\tan \alpha_2 = \frac{B_{\tan 2}}{B_{N2}} \quad \dots (18)$$

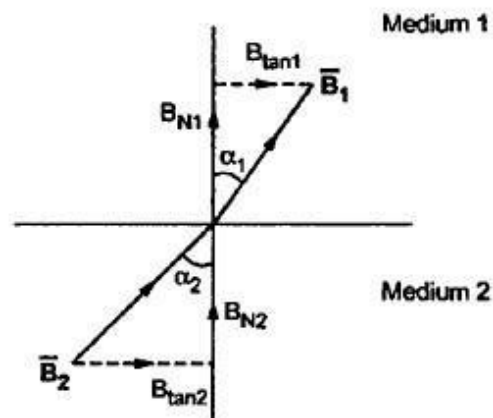


Fig. 8.15 Component of  $\bar{B}$  at boundary

Dividing equation (17) by equation (18)

$$\therefore \frac{\tan \alpha_1}{\tan \alpha_2} = \frac{B_{\tan 1}}{B_{N1}} \cdot \frac{B_{N2}}{B_{\tan 2}}$$

As we know,  $B_{N1} = B_{N2}$ ,

$$\boxed{\frac{\tan \alpha_1}{\tan \alpha_2} = \frac{B_{\tan 1}}{B_{\tan 2}} = \frac{\mu_{r1}}{\mu_{r2}}} \quad \dots (19)$$

Consider an interface between air (medium 1) and soft iron (medium 2) For air,  $\mu_{r1} = 1$ . For soft iron, let  $\mu_{r2} = 7000$ . Then

$$\frac{B_{\tan 1}}{B_{\tan 2}} = \frac{\tan \alpha_1}{\tan \alpha_2} = \frac{1}{7000}$$

If  $\alpha_2 = 85^\circ$ , then  $\alpha_1 = 0.093^\circ$  and  $B_{\tan 1} = 0$ .

Thus practically when fields cross a medium of high  $\mu_r$  to low  $\mu_r$ , then the magnetic fields  $\vec{B}$  and  $\vec{H}$  are always perpendicular to the boundary.

**UNIT - IV**

**MAGNETIC POTENTIAL**

Scalar

Magnetic Potential and Vector Magnetic Potential and its Properties - Vector Magnetic Potential due to Simple Configuration – Vector Poisson’s Equations.

Self and Mutual Inductances – Neumann’s Formulae – Determination of Self Inductance of a Solenoid and Toroid and Mutual Inductance Between a Straight, Long Wire and a Square Loop Wire in the Same Plane – Energy Stored and Intensity in a Magnetic Field – Numerical Problems.

**Magnetic Scalar and Vector Potentials:**

In studying electric field problems, we introduced the concept of electric potential that simplified the computation of electric fields for certain types of problems. In the same manner let us relate the magnetic field intensity to a **scalar magnetic potential** and write:

$$\vec{H} = -\nabla V_m \dots\dots\dots(4.21)$$

From Ampere's law , we know that

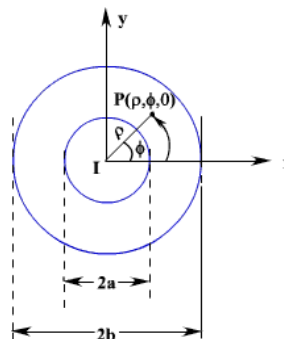
$$\nabla \times \vec{H} = \vec{J} \dots\dots\dots(4.22)$$

Therefore,.....  $\nabla \times (-\nabla V_m) = \vec{J}$  .....(4.23)

But using vector identity,  $\nabla \times (\nabla V) = 0$  we find that  $\vec{H} = -\nabla V_m$  is valid only where  $\vec{J} = 0$ . Thus the scalar magnetic potential is defined only in the region where  $\vec{J} = 0$ . Moreover,  $V_m$  in general is not a single valued function of position.

This point can be illustrated as follows. Let us consider the cross section of a coaxial line as shown in fig 4.8.

In the region  $a < \rho < b$ ,  $\vec{J} = 0$  and  $\vec{H} = \frac{I}{2\pi\rho} \hat{a}_\phi$



**Fig. 4.8: Cross Section of a Coaxial Line**

If  $V_m$  is the magnetic potential then,

$$\begin{aligned} -\nabla V_m &= -\frac{1}{\rho} \frac{\partial V_m}{\partial \phi} \\ &= \frac{I}{2\pi\phi} \end{aligned}$$

$$\therefore V_m = -\frac{I}{2\pi} \phi + c$$

If we set  $V_m = 0$  at  $\phi = 0$  then  $c=0$  and  $V_m = -\frac{I}{2\pi} \phi$

$$\therefore \text{At } \phi = \phi_0 \quad V_m = -\frac{I}{2\pi} \phi_0$$

We observe that as we make a complete lap around the current carrying conductor, we reach  $\phi_0$  again but  $V_m$  this time becomes

$$V_m = -\frac{I}{2\pi} (\phi_0 + 2\pi)$$

We observe that value of  $V_m$  keeps changing as we complete additional laps to pass through the same point. We introduced  $V_m$  analogous to electrostatic potential  $V$ . But for static electric

fields,  $\nabla \times \vec{E} = 0$  and  $\oint \vec{E} \cdot d\vec{l} = 0$ , whereas for steady magnetic field  $\nabla \times \vec{H} = \vec{J}$  wherever  $\vec{J} = 0$  but  $\oint \vec{H} \cdot d\vec{l} = I$  even if  $\vec{J} = 0$  along the path of integration.

We now introduce the **vector magnetic potential** which can be used in regions where current density may be zero or nonzero and the same can be easily extended to time varying cases. The use of vector magnetic potential provides elegant ways of solving EM field problems.

Since  $\nabla \cdot \vec{B} = 0$  and we have the vector identity that for any vector  $\vec{A}$ ,  $\nabla \cdot (\nabla \times \vec{A}) = 0$ , we can write  $\vec{B} = \nabla \times \vec{A}$ .

Here, the vector field  $\vec{A}$  is called the vector magnetic potential. Its SI unit is Wb/m. Thus if can find  $\vec{A}$  of a given current distribution,  $\vec{B}$  can be found from  $\vec{A}$  through a curl operation.

We have introduced the vector function  $\vec{A}$  and related its curl to  $\vec{B}$ . A vector function is defined fully in terms of its curl as well as divergence. The choice of  $\vec{A}$  is made as follows.

$$\nabla \times \nabla \times \vec{A} = \mu \nabla \times \vec{H} = \mu \vec{J} \quad \dots\dots\dots(4.24)$$

By using vector identity,  $\nabla \times \nabla \times \vec{A} = \nabla(\nabla \cdot \vec{A}) - \nabla^2 \vec{A}$  ..... (4.25)

$$\nabla(\nabla \cdot \vec{A}) - \nabla^2 \vec{A} = \mu \vec{J} \quad \dots\dots\dots(4.26)$$

Great deal of simplification can be achieved if we choose  $\nabla \cdot \vec{A} = 0$ . Putting  $\nabla \cdot \vec{A} = 0$ , we get  $\nabla^2 \vec{A} = -\mu \vec{J}$  which is vector poisson equation. In Cartesian coordinates, the above equation can be written in terms of the components as

$$\nabla^2 A_x = -\mu J_x \quad \dots\dots\dots(4.27a)$$

$$\nabla^2 A_y = -\mu J_y \quad \dots\dots\dots(4.27b)$$

$$\nabla^2 A_z = -\mu J_z \quad \dots\dots\dots(4.27c)$$

The form of all the above equation is same as that of

$$\nabla^2 V = -\frac{\rho}{\epsilon} \quad \dots\dots\dots(4.28)$$

for which the solution is

$$V = \frac{1}{4\pi\epsilon} \int_V \frac{\rho}{R} dv', \quad R = |\vec{r} - \vec{r}'| \quad \dots\dots\dots(4.29)$$

In case of time varying fields we shall see that  $\nabla \cdot \vec{A} = \mu\epsilon \frac{\partial V}{\partial t}$ , which is known as Lorentz condition,  $V$  being the electric potential. Here we are dealing with static magnetic field, so  $\nabla \cdot \vec{A} = 0$ .

By comparison, we can write the solution for  $A_x$  as

$$A_x = \frac{\mu}{4\pi} \int_V \frac{J_x}{R} dv' \quad \dots\dots\dots(4.30)$$

Computing similar solutions for other two components of the vector potential, the vector potential can be written as

$$\vec{A} = \frac{\mu}{4\pi} \int_V \frac{\vec{J}}{R} dv' \quad \dots\dots\dots(4.31)$$

This equation enables us to find the vector potential at a given point because of a volume current density  $\vec{J}$ . Similarly for line or surface current density we can write

$$\vec{A} = \frac{\mu}{4\pi} \int_V \frac{\vec{K}}{R} ds' \quad \dots\dots\dots(4.33)$$

The magnetic flux  $\psi$  through a given area S is given by

$$\psi = \int_S \vec{B} \cdot d\vec{s} \quad \dots\dots\dots(4.34)$$

Substituting

$$\vec{B} = \nabla \times \vec{A}$$

$$\psi = \int_S \nabla \times \vec{A} \cdot d\vec{s} = \oint_C \vec{A} \cdot d\vec{l} \quad \dots\dots\dots(4.35)$$

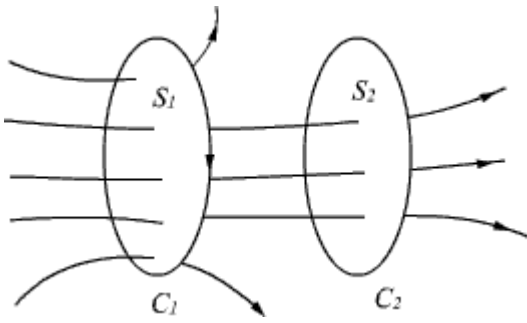
Vector potential thus have the physical significance that its integral around any closed path is equal to the magnetic flux passing through that path.

### Inductance and Inductor:

Resistance, capacitance and inductance are the three familiar parameters from circuit theory. We have already discussed about the parameters resistance and capacitance in the earlier chapters. In this section, we discuss about the parameter inductance. Before we start our discussion, let us first introduce the concept of flux linkage. If in a coil with N closely wound turns around where a current I produces a flux  $\phi$  and this flux links or encircles each of the N turns, the flux linkage  $\Lambda$  is defined as  $\Lambda = N\phi$ . In a linear medium, where the flux is proportional to the current, we define the self inductance L as the ratio of the total flux linkage to the current which they link.

$$L = \frac{\Lambda}{I} = \frac{N\phi}{I} \quad \text{i.e.,} \dots\dots\dots(4.47)$$

To further illustrate the concept of inductance, let us consider two closed loops  $C_1$  and  $C_2$  as shown in the figure 4.10,  $S_1$  and  $S_2$  are respectively the areas of  $C_1$  and  $C_2$ .



**Fig 4.10**

if a current  $I_1$  flows in  $C_1$ , the magnetic flux  $B_1$  will be created part of which will be linked to  $C_2$  as shown in Figure 4.10.

$$\phi_{12} = \int_{S_2} \vec{B}_1 \cdot d\vec{S}_2 \dots\dots\dots(4.48)$$

In a linear medium,  $\phi_{12}$  is proportional to  $I_1$ . Therefore, we can write

$$\phi_{12} = L_{12}I_1 \dots\dots\dots(4.49)$$

where  $L_{12}$  is the mutual inductance. For a more general case, if  $C_2$  has  $N_2$  turns then

$$\Lambda_{12} = N_2\phi_{12} \dots\dots\dots(4.50)$$

and  $\Lambda_{12} = L_{12}I_1$

or  $L_{12} = \frac{\Lambda_{12}}{I_1} \dots\dots\dots(4.51)$

i.e., the mutual inductance can be defined as the ratio of the total flux linkage of the second circuit to the current flowing in the first circuit.

As we have already stated, the magnetic flux produced in  $C_1$  gets linked to itself and if  $C_1$  has  $N_1$  turns then  $\Lambda_{11} = N_1\phi_{11}$ , where  $\phi_{11}$  is the flux linkage per turn.

Therefore, self inductance

$$L_{11} \text{ (or } L \text{ as defined earlier)} = \frac{\Lambda_{11}}{I_1} \dots\dots\dots(4.52)$$

As some of the flux produced by  $I_1$  links only to  $C_1$  & not  $C_2$ .

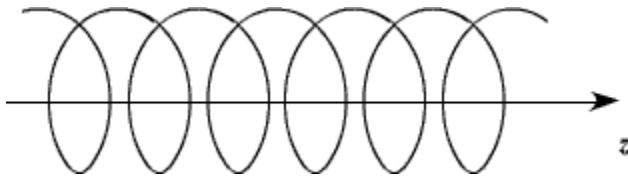


$$\Lambda_{11} = N_1\phi_{11} > N_2\phi_{12} = \Lambda_{12} \quad \dots\dots\dots(4.53)$$

Further in general, in a linear medium,  $L_{12} = \frac{d\Lambda_{12}}{dI_1}$  and  $L_{11} = \frac{d\Lambda_{11}}{dI_1}$

**Example 1:** Inductance per unit length of a very long solenoid:

Let us consider a solenoid having  $n$  turns/unit length and carrying a current  $I$ . The solenoid is air cored.



**Fig 4.11: A long current carrying solenoid**

The magnetic flux density inside such a long solenoid can be calculated as

$$\vec{B} = \mu_0 n I \hat{a}_z \quad \dots\dots\dots(4.54)$$

where the magnetic field is along the axis of the solenoid.

If  $S$  is the area of cross section of the solenoid then

$$\phi = BS = \mu_0 n I S \quad \dots\dots\dots(4.55)$$

The flux linkage per unit length of the solenoid

$$\Lambda = n\phi = \mu_0 n^2 I S \quad \dots\dots\dots(4.56)$$

∴ The inductance per unit length of the solenoid

$$L = \frac{\Lambda}{I} = \mu_0 n^2 S \quad \dots\dots\dots(4.57)$$

**Example 2:** Self inductance per unit length of a coaxial cable of inner radius 'a' and outer radius 'b'. Assume a current  $I$  flows through the inner conductor.

**Solution:**

Let us assume that the current is uniformly distributed in the inner conductor so that inside the inner conductor.

i.e.,

$$0 \leq \rho \leq a$$

$$\begin{aligned} \vec{B}_i &= \hat{a}_\phi \frac{\mu_0 I \pi \rho^2}{2\pi \rho \pi a^2} \\ &= \frac{I \mu_0 \rho}{2\pi a^2} \hat{a}_\phi \end{aligned} \dots\dots\dots(4.58)$$

and in the region ,

$$a \leq \rho \leq b$$

$$\vec{B}_e = \hat{a}_\phi \frac{\mu_0 I}{2\pi \rho} \dots\dots\dots(4.59)$$

Let us consider the flux linkage per unit length in the inner conductor. Flux enclosed between the region  $\rho$  and  $\rho+d\rho$  ( and unit length in the axial direction).

$$d\phi_i = \frac{\mu_0 I}{2\pi a^2} d\rho \dots\dots\dots(4.60)$$

Fraction of the total current it links is  $\frac{\rho^2}{a^2}$

$$\begin{aligned} \therefore d\Lambda_i &= \frac{\mu_0 I}{2\pi} \frac{\rho^3}{a^4} d\rho \\ \Lambda_i &= \int_0^a \frac{\mu_0 I}{2\pi} \frac{\rho^3}{a^4} d\rho = \frac{\mu_0 I}{8\pi} \dots\dots\dots(4.61) \end{aligned}$$

Similarly for the region  $a \leq \rho \leq b$

$$d\phi_e = \frac{\mu_0 I}{2\pi \rho} d\rho = d\lambda_e \dots\dots\dots(4.62)$$

$$\& \lambda_e = \frac{\mu_0 I}{2\pi} \int_a^b \frac{d\rho}{\rho} = \frac{\mu_0 I}{2\pi} \ln \frac{b}{a} \dots\dots\dots(4.63)$$

Total linkage

$$\begin{aligned} \Lambda &= \Lambda_i + \Lambda_e \\ &= \frac{\mu_0 I}{2\pi} \left[ \frac{1}{4} + \ln \left( \frac{b}{a} \right) \right] \end{aligned} \dots\dots\dots(4.64)$$

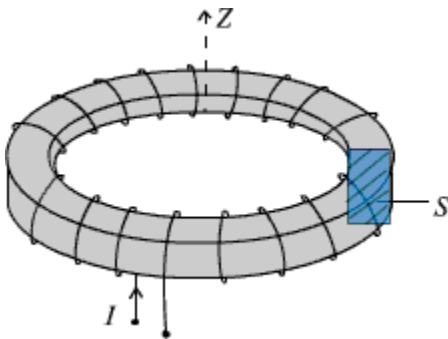
$$L = \frac{\Lambda_i + \Lambda_e}{I} = \frac{\mu_0}{2\pi} \left[ \frac{1}{4} + \ln\left(\frac{b}{a}\right) \right] \quad (4.65)$$

The self inductance, .....

Here, the first term  $\frac{\mu_0}{8\pi}$  arises from the flux linkage internal to the solid inner conductor and is the internal inductance per unit length.

In high frequency application and assuming the conductivity to be very high, the current in the internal conductor instead of being distributed throughout remain essentially concentrated on the surface of the inner conductor ( as we shall see later) and the internal inductance becomes negligibly small.

**Example 3:** Inductance of an  $N$  turn toroid carrying a filamentary current  $I$ .



**Fig 4.12:**  $N$  turn toroid carrying filamentary current  $I$ .

**Solution:** Magnetic flux density inside the toroid is given by

$$\vec{B} = \frac{\mu I}{2\pi r} \hat{a}_\phi \quad \dots\dots\dots(4.66)$$

Let the inner radius is 'a' and outer radius is 'b'. Let the cross section area 'S' is small compared to the

mean radius of the toroid  $r_0 \left[ = \frac{a+b}{2} \right]$

Then total flux

$$\phi = N \frac{\mu I}{2\pi r_0} S \quad \dots\dots\dots(4.67)$$

and flux linkage

$$\Lambda = \frac{\mu N^2 I S}{2\pi\phi_0} \dots\dots\dots(4.68)$$

The inductance

$$L = \frac{\Lambda}{I} = \frac{\mu N^2 S}{2\pi\phi_0} \dots\dots\dots(4.69)$$

### Energy stored in Magnetic Field:

So far we have discussed the inductance in static forms. In earlier chapter we discussed the fact that work is required to be expended to assemble a group of charges and this work is stated as electric energy. In the same manner energy needs to be expended in sending currents through coils and it is stored as magnetic energy. Let us consider a scenario where we consider a coil in which the current is increased from 0 to a value  $I$ . As mentioned earlier, the self inductance of a coil in general can be written as

$$L = \frac{d\Lambda}{di} = N \frac{d\phi}{di} \dots\dots\dots(4.70a)$$

or  $L di = N d\phi \dots\dots\dots(4.70b)$

If we consider a time varying scenario,

$$L \frac{di}{dt} = N \frac{d\phi}{dt} \dots\dots\dots(4.71)$$

We will later see that  $N \frac{d\phi}{dt}$  is an induced voltage.

$\therefore v = L \frac{di}{dt}$  is the voltage drop that appears across the coil and thus voltage opposes the change of current.

Therefore in order to maintain the increase of current, the electric source must do an work against this induced voltage.

$$\begin{aligned} dW &= vi dt \\ &= Li di \end{aligned} \dots\dots\dots(4.72)$$

$$\& \quad W = \int_0^I Li \, di = \frac{1}{2} LI^2 \quad (\text{Joule}) \dots\dots\dots(4.73)$$

which is the energy stored in the magnetic circuit.

We can also express the energy stored in the coil in term of field quantities.

For linear magnetic circuit

$$W = \frac{1}{2} \frac{N\phi}{l} I^2 = \frac{1}{2} N\phi I \quad \dots\dots\dots(4.74)$$

Now, 
$$\phi = \int_s \vec{B} \cdot d\vec{S} = BA \quad \dots\dots\dots(4.75)$$

where  $A$  is the area of cross section of the coil. If  $l$  is the length of the coil

$$NI = Hl$$

$$\therefore W = \frac{1}{2} HBAI \quad \dots\dots\dots(4.76)$$

$Al$  is the volume of the coil. Therefore the magnetic energy density i.e., magnetic energy/unit volume is given by

$$W_m = \frac{W}{Al} = \frac{1}{2} BH \quad \dots\dots\dots(4.77)$$

In vector form

$$W_m = \frac{1}{2} \vec{B} \cdot \vec{H} \quad \text{J/mt}^3 \dots\dots\dots(4.78)$$

is the energy density in the magnetic field.

## UNIT - V TIME VARYING FIELDS

Faraday's Law of Electromagnetic Induction – It's Integral and Point Forms – Maxwell's Fourth Equation. Statically and Dynamically Induced E.M.F's – Simple Problems – Modified Maxwell's Equations for Time Varying Fields – Displacement Current.

Wave Equations – Uniform Plane Wave Motion in Free Space, Conductors and Dielectrics – Velocity, Wave Length, Intrinsic Impedence and Skin Depth – Poynting Theorem – Poynting Vector and its Significance.

### Faraday's Law of electromagnetic Induction

Michael Faraday, in 1831 discovered experimentally that a current was induced in a conducting loop when the magnetic flux linking the loop changed. In terms of fields, we can say that a time varying magnetic field produces an electromotive force (emf) which causes a current in a closed circuit. The quantitative relation between the induced emf (the voltage that arises from conductors moving in a magnetic field or from changing magnetic fields) and the rate of change of flux linkage developed based on experimental observation is known as Faraday's law. Mathematically, the induced emf can be written as

$$\text{Emf} = - \frac{d\phi}{dt} \quad \text{Volts} \quad (5.3)$$

where  $\phi$  is the flux linkage over the closed path.

A non zero  $\frac{d\phi}{dt}$  result due to any of the following:

- (a) time changing flux linkage a stationary closed path.
- (b) relative motion between a steady flux a closed path.
- (c) a combination of the above two cases.

The negative sign in equation (5.3) was introduced by Lenz in order to comply with the polarity of the induced emf. The negative sign implies that the induced emf will cause a current flow in the closed loop in such a direction so as to oppose the change in the linking magnetic flux which produces it. (It may be noted that as far as the induced emf is concerned, the closed path forming a loop does not necessarily have to be conductive).

If the closed path is in the form of N tightly wound turns of a coil, the change in the magnetic flux linking the coil induces an emf in each turn of the coil and total emf is the sum of the induced emfs of the individual turns, i.e.,

$$\text{Emf} = -N \frac{d\phi}{dt} \quad \text{Volts} \quad (5.4)$$

By defining the total flux linkage as

$$\lambda = N\phi \quad (5.5)$$

The emf can be written as

$$\text{Emf} = - \frac{d\lambda}{dt} \quad (5.6)$$

Continuing with equation (5.3), over a closed contour 'C' we can write

$$\text{Emf} = \oint_C \vec{E} \cdot d\vec{l} \quad (5.7)$$

where  $\vec{E}$  is the induced electric field on the conductor to sustain the current.

Further, total flux enclosed by the contour 'C' is given by

$$\phi = \int_S \vec{B} \cdot d\vec{s} \quad (5.8)$$

Where S is the surface for which 'C' is the contour.

From (5.7) and using (5.8) in (5.3) we can write

$$\oint_C \vec{E} \cdot d\vec{l} = - \frac{\partial}{\partial t} \oint_S \vec{B} \cdot d\vec{s} \quad (5.9)$$

By applying stokes theorem

$$\int_S \nabla \times \vec{E} \cdot d\vec{s} = - \int_S \frac{\partial \vec{B}}{\partial t} \cdot d\vec{s} \quad (5.10)$$

Therefore, we can write

$$\nabla \times \vec{E} = - \frac{\partial \vec{B}}{\partial t} \quad (5.11)$$

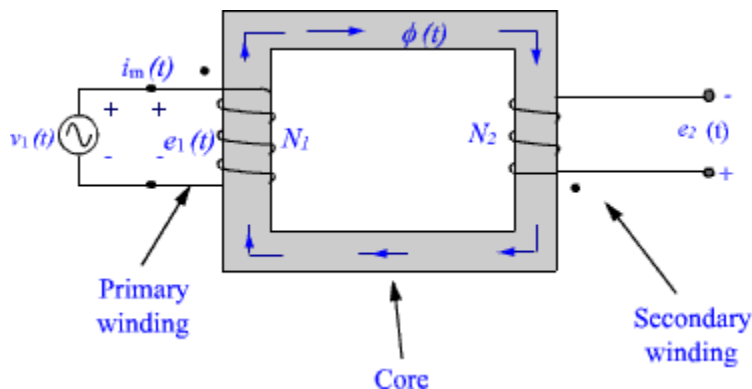
which is the Faraday's law in the point form

$$\frac{d\phi}{dt}$$

We have said that non zero ~~can~~ be produced in a several ways. One particular case is when a time varying flux linking a stationary closed path induces an emf. The emf induced in a stationary closed path by a time varying magnetic field is called a **transformer emf**.

### Example: Ideal transformer

As shown in figure 5.1, a transformer consists of two or more numbers of coils coupled magnetically through a common core. Let us consider an ideal transformer whose winding has zero resistance, the core having infinite permittivity and magnetic losses are zero.



**Fig 5.1: Transformer with secondary open**

These assumptions ensure that the magnetization current under no load condition is vanishingly small and can be ignored. Further, all time varying flux produced by the primary winding will follow the magnetic path inside the core and link to the secondary coil without any leakage. If  $N_1$  and  $N_2$  are the number of turns in the primary and the secondary windings respectively, the induced emfs are

$$e_1 = N_1 \frac{d\phi}{dt} \quad (5.12a)$$

$$e_2 = N_2 \frac{d\phi}{dt} \quad (5.12b)$$

(The polarities are marked, hence negative sign is omitted. The induced emf is +ve at the dotted end of the winding.)

$$\therefore \frac{e_1}{e_2} = \frac{N_1}{N_2} \quad (5.13)$$



i.e., the ratio of the induced emfs in primary and secondary is equal to the ratio of their turns. Under ideal condition, the induced emf in either winding is equal to their voltage rating.

$$\frac{v_1}{v_2} = \frac{N_1}{N_2} = a \quad (5.14)$$

where 'a' is the transformation ratio. When the secondary winding is connected to a load, the current flows in the secondary, which produces a flux opposing the original flux. The net flux in the core decreases and induced emf will tend to decrease from the no load value. This causes the primary current to increase to nullify the decrease in the flux and induced emf. The current continues to increase till the flux in the core and the induced emfs are restored to the no load values. Thus the source supplies power to the primary winding and the secondary winding delivers the power to the load. Equating the powers

$$i_1 v_1 = i_2 v_2 \quad (5.15)$$

$$\frac{i_2}{i_1} = \frac{v_1}{v_2} = \frac{e_1}{e_2} = \frac{N_1}{N_2} \quad (5.16)$$

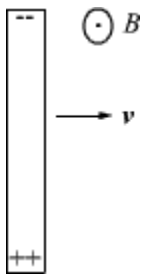
Further,

$$i_2 N_2 - i_1 N_1 = 0 \quad (5.17)$$

i.e., the net magnetomotive force (mmf) needed to excite the transformer is zero under ideal condition.

### Motional EMF:

Let us consider a conductor moving in a steady magnetic field as shown in the fig 5.2.



**Fig 5.2**

If a charge  $Q$  moves in a magnetic field  $\vec{B}$ , it experiences a force

$$\vec{F} = Q\vec{v} \times \vec{B} \quad (5.18)$$

This force will cause the electrons in the conductor to drift towards one end and leave the other end positively charged, thus creating a field and charge separation continuous until electric and magnetic forces balance and an equilibrium is reached very quickly, the net force on the moving conductor is zero.

$\frac{\vec{F}}{Q} = \vec{v} \times \vec{B}$  can be interpreted as an induced electric field which is called the motional electric field

$$\vec{E}_m = \vec{v} \times \vec{B} \quad (5.19)$$

If the moving conductor is a part of the closed circuit C, the generated emf around the circuit is  $\oint_C \vec{v} \times \vec{B} \cdot d\vec{l}$ . This emf is called the **motional emf**.

A classic example of **motional emf** is given in Additional Solved Example No.1 .

### Maxwell's Equation

Equation (5.1) and (5.2) gives the relationship among the field quantities in the static field. For time varying case, the relationship among the field vectors written as

$$\nabla \times \vec{E} = -\frac{\partial \vec{B}}{\partial t} \quad (5.20a)$$

$$\nabla \times \vec{H} = \vec{J} \quad (5.20b)$$

$$\nabla \cdot \vec{D} = \rho \quad (5.20c)$$

$$\nabla \cdot \vec{B} = 0 \quad (5.20d)$$

In addition, from the principle of conservation of charges we get the equation of continuity

$$\nabla \cdot \vec{J} = -\frac{\partial \rho}{\partial t} \quad (5.21)$$

The equation 5.20 (a) - (d) must be consistent with equation (5.21).

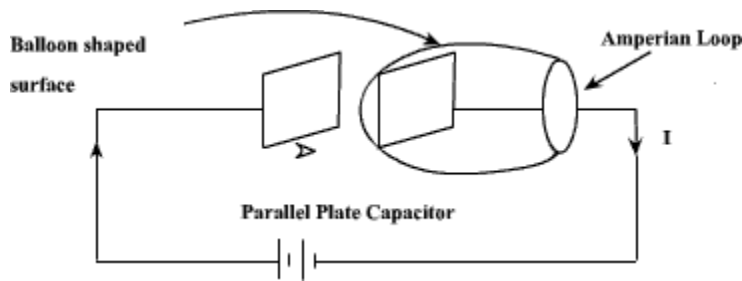
We observe that

$$\nabla \cdot \nabla \times \vec{H} = 0 = \nabla \cdot \vec{J} \quad (5.22)$$

Since  $\nabla \cdot \nabla \times \vec{A}$  is zero for any vector  $\vec{A}$ .

Thus  $\nabla \times \vec{H} = \vec{J}$  applies only for the static case i.e., for the scenario when  $\frac{\partial \rho}{\partial t} = 0$ .  
A classic example for this is given below .

Suppose we are in the process of charging up a capacitor as shown in fig 5.3.



**Fig 5.3**

Let us apply the Ampere's Law for the Amperian loop shown in fig 5.3.  $I_{enc} = I$  is the total current passing through the loop. But if we draw a balloon shaped surface as in fig 5.3, no current passes through this surface and hence  $I_{enc} = 0$ . But for non steady currents such as this one, the concept of current enclosed by a loop is ill-defined since it depends on what surface you use. In fact Ampere's Law should also hold true for time varying case as well, then comes the idea of displacement current which will be introduced in the next few slides.

We can write for time varying case,

$$\begin{aligned} \nabla \cdot (\nabla \times \vec{H}) &= 0 = \nabla \cdot \vec{J} + \frac{\partial \rho}{\partial t} \\ &= \nabla \cdot \vec{J} + \frac{\partial}{\partial t} \nabla \cdot \vec{D} \\ &= \nabla \cdot \left( \vec{J} + \frac{\partial \vec{D}}{\partial t} \right) \end{aligned} \quad (5.23)$$

$$\therefore \nabla \times \vec{H} = \vec{J} + \frac{\partial \vec{D}}{\partial t} \quad (5.24)$$

The equation (5.24) is valid for static as well as for time varying case.

Equation (5.24) indicates that a time varying electric field will give rise to a magnetic field even in the absence of  $\vec{J}$ . The term  $\frac{\partial \vec{D}}{\partial t}$  has a dimension of current densities ( $A/m^2$ ) and is called the displacement current density.

Introduction of  $\frac{\partial \vec{D}}{\partial t}$  in  $\nabla \times \vec{H}$  equation is one of the major contributions of James Clerk Maxwell. The modified set of equations

$$\nabla \times \vec{E} = -\frac{\partial \vec{B}}{\partial t} \quad (5.25a)$$

$$\nabla \times \vec{H} = \vec{J} + \frac{\partial \vec{D}}{\partial t} \quad (5.25b)$$

$$\nabla \cdot \vec{D} = \rho \quad (5.25c)$$

$$\nabla \cdot \vec{B} = 0 \quad (5.25d)$$

is known as the Maxwell's equation and this set of equations apply in the time varying scenario, static fields are being a particular case  $\left(\frac{\partial}{\partial t} = 0\right)$ .

In the integral form

$$\oint_c \vec{E} \cdot d\vec{l} = - \int_s \frac{\partial \vec{B}}{\partial t} \cdot d\vec{S} \quad (5.26a)$$

$$\oint_c \vec{H} \cdot d\vec{l} = \int_s \left( \vec{J} + \frac{\partial \vec{D}}{\partial t} \right) \cdot d\vec{S} = I + \int_s \frac{\partial \vec{D}}{\partial t} \cdot d\vec{S} \quad (5.26b)$$

$$\int_v \nabla \cdot \vec{D} \, dv = \oint_s \vec{D} \cdot d\vec{S} = \int_v \rho \, dv \quad (5.26c)$$

$$\oint_s \vec{B} \cdot d\vec{S} = 0 \quad (5.26d)$$

The modification of Ampere's law by Maxwell has led to the development of a unified electromagnetic field theory. By introducing the displacement current term, Maxwell could predict the propagation of EM waves. Existence of EM waves was later demonstrated by Hertz experimentally which led to the new era of radio communication.

## 10.2 General Wave Equations

In general the wave equations can be obtained by relating the space and time variations of the electric and magnetic fields, using the Maxwell's equations.

To obtain general wave equations, let us assume that the electric and magnetic fields exist in a linear, homogeneous and isotropic medium with the parameters  $\mu$ ,  $\epsilon$  and  $\sigma$ . Also assume that the medium is source free which clearly gives the idea about the charge free medium. Assume that the medium obeys the ohm's law i.e.  $\bar{J} = \sigma \bar{E}$ . Then the Maxwell's equations are given by,

$$\nabla \times \bar{E} = -\mu \frac{\partial \bar{H}}{\partial t} \quad \dots(1)$$

$$\nabla \times \bar{H} = \sigma \bar{E} + \epsilon \frac{\partial \bar{E}}{\partial t} \quad \dots(2)$$

$$\nabla \cdot \bar{B} = 0 \quad \text{i.e.} \quad \nabla \cdot \bar{H} = 0 \quad \dots(3)$$

$$\nabla \cdot \bar{D} = 0 \quad \text{i.e.} \quad \nabla \cdot \bar{E} = 0 \quad \dots(4)$$

To eliminate  $\bar{H}$  from equation (1), taking curl on both the sides of equation (1), we get,

$$\nabla \times (\nabla \times \bar{E}) = -\mu \left( \nabla \times \frac{\partial \bar{H}}{\partial t} \right) \quad \dots(5)$$

$\nabla$  operates indicates differentiation with respect to space while  $\frac{\partial}{\partial t}$  operates differentiation with respect to time. Both are independent of each other, the operators can be interchanged.

So we get,

$$\nabla \times \nabla \times \bar{E} = -\mu \frac{\partial}{\partial t} (\nabla \times \bar{H}) \quad \dots(6)$$

Substituting value of  $\nabla \times \bar{H}$  from equation (2), we get,

$$\begin{aligned} \nabla \times \nabla \times \bar{E} &= -\mu \frac{\partial}{\partial t} \left[ \sigma \bar{E} + \epsilon \frac{\partial \bar{E}}{\partial t} \right] \\ \nabla \times \nabla \times \bar{E} &= -\mu \sigma \frac{\partial \bar{E}}{\partial t} - \mu \epsilon \frac{\partial^2 \bar{E}}{\partial t^2} \end{aligned} \quad \dots(7)$$

Now according to the vector identity,

$$\nabla \times \nabla \times \bar{E} = \nabla (\nabla \cdot \bar{E}) - \nabla^2 \bar{E} \quad \dots(8)$$

Substituting  $\nabla \cdot \bar{E} = 0$  from equation (4), we can modify equation (8) as,

$$\nabla \times \nabla \times \bar{E} = -\nabla^2 \bar{E} \quad \dots(9)$$

Substituting value of  $\nabla \times \nabla \times \bar{E}$  from equation (9) in equation (2) we get,

$$-\nabla^2 \bar{E} = -\mu \sigma \frac{\partial \bar{E}}{\partial t} - \mu \epsilon \frac{\partial^2 \bar{E}}{\partial t^2}$$

$$\therefore \boxed{\nabla^2 \bar{E} = \mu \sigma \frac{\partial \bar{E}}{\partial t} + \mu \epsilon \frac{\partial^2 \bar{E}}{\partial t^2}} \quad \dots(10)$$

This is the **wave** equation for the electric field  $\bar{E}$ . Now multiplying both the sides of equation (10) by  $\epsilon$ ,

$$\nabla^2(\epsilon \bar{E}) = \mu \sigma \frac{\partial \epsilon \bar{E}}{\partial t} + \mu \epsilon \frac{\partial^2 \epsilon \bar{E}}{\partial t^2}$$

$$\text{i.e.} \quad \boxed{\nabla^2 \bar{D} = \mu \sigma \frac{\partial \bar{D}}{\partial t} + \mu \epsilon \frac{\partial^2 \bar{D}}{\partial t^2}} \quad \dots(11)$$

This is the **wave** equation for  $\bar{D}$  in **uniform** medium.

Exactly on the similar lines, the **wave** equation for  $\bar{H}$  can be obtained by taking curl on both the sides of equation (2), we get,

$$\nabla \times (\nabla \times \bar{H}) = \nabla \times (\sigma \bar{E}) + \epsilon \nabla \times \frac{\partial \bar{E}}{\partial t} \quad \dots(12)$$

As  $\nabla$  operator and  $\frac{\partial}{\partial t}$  represent independent relationship between the two, we can interchange them as follows.

$$\nabla \times \nabla \times \bar{H} = \sigma (\nabla \times \bar{E}) + \epsilon \frac{\partial}{\partial t} (\nabla \times \bar{E}) \quad \dots(13)$$

Substituting  $\nabla \times \bar{E} = -\mu \frac{\partial \bar{H}}{\partial t}$  in equation (12), we get,

$$\nabla \times \nabla \times \bar{H} = \sigma \left( -\mu \frac{\partial \bar{H}}{\partial t} \right) + \epsilon \left( -\mu \frac{\partial \bar{H}}{\partial t} \right)$$

$$\therefore \nabla \times \nabla \times \bar{H} = -\mu \sigma \frac{\partial \bar{H}}{\partial t} - \mu \epsilon \frac{\partial \bar{H}}{\partial t} \quad \dots(14)$$

From the vector identity,

$$\nabla \times \nabla \times \bar{H} = \nabla(\nabla \cdot \bar{H}) - \nabla^2 \bar{H} \quad \dots(15)$$

Substituting  $\nabla \cdot \bar{H} = 0$  from equation (4) in equation (15), we get

$$\nabla \times \nabla \times \bar{H} = -\nabla^2 \bar{H} \quad \dots(16)$$

Substituting value of  $\nabla \times \nabla \times \bar{H}$  in equation (14) we get,

$$-\nabla^2 \bar{H} = -\mu \sigma \frac{\partial \bar{H}}{\partial t} - \mu \epsilon \frac{\partial \bar{H}}{\partial t}$$

$$\text{i.e.} \quad \boxed{\nabla^2 \bar{H} = \mu \sigma \frac{\partial \bar{H}}{\partial t} + \mu \epsilon \frac{\partial^2 \bar{H}}{\partial t^2}} \quad \dots(17)$$

This is the **wave** equation for the magnetic field  $\bar{H}$ . Now multiplying both the sides by  $\mu$ , we get,

$$\nabla^2(\mu \bar{H}) = \mu \sigma \frac{\partial \mu \bar{H}}{\partial t} + \mu \epsilon \frac{\partial^2(\mu \bar{H})}{\partial t^2}$$

$$\therefore \boxed{\nabla^2 \bar{\mathbf{B}} = \mu \sigma \frac{\partial \bar{\mathbf{B}}}{\partial t} + \mu \epsilon \frac{\partial^2 \bar{\mathbf{B}}}{\partial t^2}} \quad \dots(18)$$

This is the **wave** equation for  $\bar{\mathbf{D}}$  in the **uniform** medium. Hence **in** general we can write,

$$\nabla^2 \begin{bmatrix} \bar{\mathbf{E}} \\ \bar{\mathbf{D}} \\ \bar{\mathbf{H}} \\ \bar{\mathbf{B}} \end{bmatrix} = \mu \sigma \frac{\partial}{\partial t} \begin{bmatrix} \bar{\mathbf{E}} \\ \bar{\mathbf{D}} \\ \bar{\mathbf{H}} \\ \bar{\mathbf{B}} \end{bmatrix} + \mu \epsilon \frac{\partial^2}{\partial t^2} \begin{bmatrix} \bar{\mathbf{E}} \\ \bar{\mathbf{D}} \\ \bar{\mathbf{H}} \\ \bar{\mathbf{B}} \end{bmatrix} \quad \dots(19)$$

Above equation is three dimensional equation for all the field vectors.

## 9.2 Uniform Plane Wave in Free Space

Assume an electromagnetic **wave** travelling in free space. Consider that an electric field is in x-direction; while a magnetic field is in y-direction. Both the fields will not vary with x and y; but with z only. They will also change with time as the **wave** propagates in free space.

Consider Maxwell's equation expressed in  $\bar{\mathbf{E}}$  and  $\bar{\mathbf{H}}$  as

$$\nabla \times \bar{\mathbf{H}} = \bar{\mathbf{J}} + \frac{\partial \bar{\mathbf{D}}}{\partial t}$$

Let us assume that a free space is perfect dielectric, then  $\bar{\mathbf{J}} = 0$ ,

$$\therefore \nabla \times \bar{\mathbf{H}} = \frac{\partial \bar{\mathbf{D}}}{\partial t}$$

Expressing  $\bar{\mathbf{D}}$  in rectangular co-ordinate system,

$$\nabla \times \bar{\mathbf{H}} = \frac{\partial}{\partial t} [D_x \bar{\mathbf{a}}_x + D_y \bar{\mathbf{a}}_y + D_z \bar{\mathbf{a}}_z]$$

Writing curl of  $\bar{\mathbf{H}}$  on left of equation,

$$\begin{aligned} & \left[ \frac{\partial H_z}{\partial y} - \frac{\partial H_y}{\partial z} \right] \bar{\mathbf{a}}_x + \left[ \frac{\partial H_x}{\partial z} - \frac{\partial H_z}{\partial x} \right] \bar{\mathbf{a}}_y + \left[ \frac{\partial H_y}{\partial x} - \frac{\partial H_x}{\partial y} \right] \bar{\mathbf{a}}_z \\ &= \frac{\partial}{\partial t} [D_x \bar{\mathbf{a}}_x + D_y \bar{\mathbf{a}}_y + D_z \bar{\mathbf{a}}_z] \end{aligned}$$

As  $\bar{\mathbf{H}}$  is in y-direction,  $H_x = H_z = 0$ ,

$$\therefore -\frac{\partial H_y}{\partial z} \bar{\mathbf{a}}_x + \frac{\partial H_y}{\partial x} \bar{\mathbf{a}}_z = \frac{\partial}{\partial t} [D_x \bar{\mathbf{a}}_x + D_y \bar{\mathbf{a}}_y + D_z \bar{\mathbf{a}}_z]$$

Also  $H_y$  is not changing with  $x$ , as it is **uniform** in  $x$ - $y$  **plane**, so  $\frac{\partial H_y}{\partial x} = 0$

$$\therefore -\frac{\partial H_y}{\partial z} \bar{\mathbf{a}}_x = \frac{\partial}{\partial t} [D_x \bar{\mathbf{a}}_x + D_y \bar{\mathbf{a}}_y + D_z \bar{\mathbf{a}}_z]$$

Equating L.H.S. and R.H.S. of above equation directionwise, we can write,

$$-\frac{\partial H_y}{\partial z} = \frac{\partial D_x}{\partial t}$$

$$\therefore -\frac{\partial H_y}{\partial z} = \epsilon \frac{\partial E_x}{\partial t} \quad \dots \quad \because \bar{\mathbf{D}} = \epsilon \bar{\mathbf{E}}$$

$$\therefore \frac{\partial H_y}{\partial z} = -\epsilon \frac{\partial E_x}{\partial t} \quad \dots (1)$$

Now consider Maxwell's equation derived **from** Faraday's law,

$$\nabla \times \bar{\mathbf{E}} = -\frac{\partial \bar{\mathbf{B}}}{\partial t}$$

Using rectangular co-ordinate system, we can write,

$$\begin{aligned} & \left[ \frac{\partial E_y}{\partial z} - \frac{\partial E_z}{\partial y} \right] \bar{\mathbf{a}}_x + \left[ \frac{\partial E_x}{\partial z} - \frac{\partial E_z}{\partial x} \right] \bar{\mathbf{a}}_y + \left[ \frac{\partial E_x}{\partial y} - \frac{\partial E_y}{\partial x} \right] \bar{\mathbf{a}}_z \\ &= -\frac{\partial}{\partial t} [B_x \bar{\mathbf{a}}_x + B_y \bar{\mathbf{a}}_y + B_z \bar{\mathbf{a}}_z] \end{aligned}$$



As  $\vec{E}$  is in x-direction,  $E_y = E_z = 0$ ,

$$\therefore \frac{\partial E_x}{\partial z} \vec{a}_y + \frac{\partial E_x}{\partial y} \vec{a}_z = -\frac{\partial}{\partial t} [B_x \vec{a}_x + B_y \vec{a}_y + B_z \vec{a}_z]$$

Also component  $E_x$  is not varying with  $y$ , as it is **uniform** in x-y plane, so  $\frac{\partial E_x}{\partial y} = 0$ ,

$$\therefore \frac{\partial E_x}{\partial z} \vec{a}_y = -\frac{\partial}{\partial t} [B_x \vec{a}_x + B_y \vec{a}_y + B_z \vec{a}_z]$$

Equating L.H.S. and R.H.S. of above equation directionwise, we can write,

$$\frac{\partial E_x}{\partial z} = -\frac{\partial B_y}{\partial t}$$

$$\therefore \frac{\partial E_x}{\partial z} = -\mu \frac{\partial H_y}{\partial t} \quad \dots\dots\dots \vec{B} = \mu \vec{H}$$

$$\therefore \frac{\partial H_y}{\partial t} = -\frac{1}{\mu} \frac{\partial E_x}{\partial z} \quad \dots (2)$$

Differentiating equation (1) with respect to  $t$ ,

$$\frac{\partial}{\partial t} \left[ \frac{\partial H_y}{\partial z} \right] = -\epsilon \frac{\partial^2 E_x}{\partial t^2} \quad \dots (3)$$

Now differentiating equation (2) with respect to  $z$ ,

$$\frac{\partial}{\partial z} \left[ \frac{\partial H_y}{\partial t} \right] = -\frac{1}{\mu} \frac{\partial^2 E_x}{\partial z^2} \quad \dots (4)$$

Now observe L.H.S. of equations (3) and (4). As we can change order of differentiation, L.H.S. of equations (3) and (4) is same. So equating R.H.S. of both the equations,

$$\therefore \epsilon \frac{\partial^2 E_x}{\partial t^2} = \frac{1}{\mu} \frac{\partial^2 E_x}{\partial z^2}$$

$$\therefore \frac{\partial^2 E_x}{\partial t^2} = \frac{1}{\mu \epsilon} \frac{\partial^2 E_x}{\partial z^2} \quad \dots (5)$$

According to the results in physics,

$$v = \frac{1}{\sqrt{\mu \epsilon}}$$

where  $v$  is the velocity of propagation also called **wave velocity**. For the free space it is denoted by  $c$  and its value is  $3 \times 10^8$  m/s.

Hence we can rewrite equation (5) as,

$$\boxed{\frac{\partial^2 E_x}{\partial t^2} = v^2 \frac{\partial^2 E_x}{\partial z^2}} \quad \dots (6)$$

Above equation is the **wave equation** and it is differential equation of second order. Solving this equation mathematically, the solution is given by

$$\boxed{E_x = E_m^+ \cos(\omega t - \beta z) + E_m^- \cos(\omega t + \beta z) \text{ V / m}} \quad \dots (7)$$

Above equation (7) is a sinusoidal function consisting two components of an electric field ; one in forward direction and other in backward direction. The **wave** consists one component of the field travelling in positive z direction having amplitude  $E_m^+$  ; while other component having amplitude  $E_m^-$  travelling in negative z direction.

We can rewrite equation (7) as follows,

$$E_x = E_m^+ \cos\omega\left(t - \frac{\beta}{\omega} z\right) + E_m^- \cos\omega\left(t + \frac{\beta}{\omega} z\right) \text{ V / m} \quad \dots (8)$$

Two partial differentiations of equation (8) with respect to z and t yields a similar equation given by

$$\frac{\partial^2 E_x}{\partial z^2} = \frac{\beta^2}{\omega^2} \left( \frac{\partial^2 E_x}{\partial t^2} \right) \quad \dots (9)$$

It is clear that equations (6) and (9) are similar equations. So comparing these two equations we can get another expression for velocity as,

$$v = \frac{\omega}{\beta} \text{ m/s} \quad \dots (10)$$

We can obtain similar type of equations for magnetic field  $\vec{H}$  by considering equation (2) and putting value of  $E_x$  from equation (8),

$$\begin{aligned} \frac{\partial H_y}{\partial t} &= -\frac{1}{\mu} \frac{\partial}{\partial z} \left[ E_m^+ \cos\omega\left(t - \frac{\beta}{\omega} z\right) + E_m^- \cos\omega\left(t + \frac{\beta}{\omega} z\right) \right] \\ \therefore \frac{\partial H_y}{\partial t} &= -\frac{1}{\mu} \left[ \beta E_m^+ \sin\omega\left(t - \frac{\beta}{\omega} z\right) - \beta E_m^- \sin\omega\left(t + \frac{\beta}{\omega} z\right) \right] \end{aligned}$$

Integrating both sides with respect to time, we get,

$$H_y = \frac{\beta}{\omega\mu} E_m^+ \cos\omega\left(t - \frac{\beta}{\omega} z\right) - \frac{\beta}{\omega\mu} E_m^- \cos\omega\left(t + \frac{\beta}{\omega} z\right)$$

$$\therefore \boxed{H_y = H_m^+ \cos(\omega t - \beta z) - H_m^- \cos(\omega t + \beta z) \text{ A / m}} \quad \dots (11)$$

This equation is similar to equation (7) representing two components of a magnetic field one in forward direction while other in backward direction.

From equations (7) and (11) it is clear that when we assume x component for  $\vec{E}$ , it results in y component for  $\vec{H}$ . Both  $\vec{E}$  and  $\vec{H}$  are in time phase and both are perpendicular to each other. Both these fields lie in a plane which is perpendicular to the direction of wave propagation. Thus  $\vec{E}$  and  $\vec{H}$  together form **transverse electromagnetic (TEM) wave**; with one forward travelling wave in the positive z-direction with velocity  $\frac{\omega}{\beta}$  and another backward travelling wave in negative z-direction with the same velocity. Thus  $\vec{E}$  and  $\vec{H}$  are only the functions of direction of travel and time.

In general, when any wave propagates in the medium, it gets attenuated. The amplitude of the signal reduces. This is represented by an **attenuation constant**  $\alpha$ . It is measured in neper per meter (Np/m). But practically it is expressed in decibel (dB). The conversion between a basic unit neper (Np) and decibel (dB) is given by

$$1 \text{ Np} = 8.686 \text{ dB}$$

It is also observed that when a wave propagates, phase change also takes place. Such a phase change is expressed by a **phase constant**  $\beta$ . It is measured in radian per meter (rad/m).

So attenuation constant ( $\alpha$ ) and phase constant ( $\beta$ ) together constitutes a propagation constant of medium for **uniform plane wave**. It is represented by  $\gamma$ . It is expressed per unit length as

$$\gamma = \alpha + j\beta \quad \dots (12)$$

The ratio of amplitudes of  $\vec{E}$  to  $\vec{H}$  of the waves in either direction is called **intrinsic impedance** of the material in which wave is travelling. It is denoted by  $\eta$  and given by,

$$\eta = \frac{E_m^+}{H_m^+} = -\frac{E_m^-}{H_m^-} = \frac{\omega\mu}{\beta} = v \cdot \mu \Omega \quad \dots (13)$$

But as we know,  $v = \frac{\omega}{\beta} = \frac{1}{\sqrt{\mu\epsilon}}$ ,

$$\therefore \eta = \frac{\mu}{\sqrt{\mu\epsilon}} = \sqrt{\frac{\mu}{\epsilon}} \Omega \quad \dots (14)$$

For free space, intrinsic impedance is denoted by  $\eta_0$ ,

$$\eta_0 = \sqrt{\frac{\mu_0}{\epsilon_0}} \approx 120 \pi \Omega = 377 \Omega \quad \dots (15)$$

and

$$v = c = \frac{1}{\sqrt{\mu_0 \epsilon_0}} \approx 3 \times 10^8 \text{ m/s} \quad \dots (16)$$

In general, **wave** repeats itself after  $2\pi$  radians. In otherwords, if  $\lambda$  is the length of one cycle of sinusoidal signal, then signal changes phase by  $360^\circ$  or  $2\pi$  radians. So we can write relation between  $\lambda$  and  $\beta$  as,

$$\lambda = \frac{2\pi}{\beta} \text{ m} \quad \dots (17)$$

Multiplying both sides of equation (17) by frequency  $f$ ,

$$\therefore (f)(\lambda) = \frac{2\pi f}{\beta} = \frac{\omega}{\beta} = v$$

Thus velocity of propagation or **wave** velocity is given by,

$$v = f \lambda \text{ m/s} \quad \dots (18)$$

### 9.3 Wave Equations in Phasor Form

An electromagnetic **wave** in a medium can be completely defined if intrinsic impedance ( $\eta$ ) and propagation constant ( $\gamma$ ) of a medium is known. Thus it is necessary to derive the expressions for  $\eta$  and  $\gamma$  in terms of the properties of a medium such as permeability ( $\mu$ ), permittivity ( $\epsilon$ ), conductivity ( $\sigma$ ) etc.

Consider Maxwell's equation derived **from** Faraday's law,

$$\nabla \times \bar{\mathbf{E}} = -\frac{\partial \bar{\mathbf{B}}}{\partial t} = -\mu \frac{\partial \bar{\mathbf{H}}}{\partial t} \quad \dots (1)$$

Taking curl on both the sides of the equation,

$$\therefore \nabla \times \nabla \times \bar{\mathbf{E}} = -\mu \left[ \nabla \times \frac{\partial \bar{\mathbf{H}}}{\partial t} \right]$$

$$\therefore \nabla \times \nabla \times \bar{\mathbf{E}} = -\mu \left[ \frac{\partial}{\partial t} (\nabla \times \bar{\mathbf{H}}) \right] \quad \dots (2)$$

Using vector identity to the left of equation (2),

$$\therefore \nabla(\nabla \cdot \bar{\mathbf{E}}) - \nabla^2 \bar{\mathbf{E}} = -\mu \left[ \frac{\partial}{\partial t} (\nabla \times \bar{\mathbf{H}}) \right] \quad \dots (3)$$

But according to another Maxwell's equation,

$$\nabla \times \bar{\mathbf{H}} = \bar{\mathbf{J}} + \frac{\partial \bar{\mathbf{D}}}{\partial t}$$

Putting value of  $\nabla \times \bar{\mathbf{H}}$  in equation (3),

$$\therefore \nabla(\nabla \cdot \bar{\mathbf{E}}) - \nabla^2 \bar{\mathbf{E}} = -\mu \left[ \frac{\partial}{\partial t} \left( \bar{\mathbf{J}} + \frac{\partial \bar{\mathbf{D}}}{\partial t} \right) \right] \quad \dots (4)$$

Since most of the regions are source or charge free,

$$\therefore \nabla \cdot \bar{\mathbf{E}} = 0$$

$$\therefore \nabla(\nabla \cdot \bar{\mathbf{E}}) = 0$$

Putting value of  $\nabla(\nabla \cdot \bar{\mathbf{E}})$  in equation (4), assuming charge free medium,

$$-\nabla^2 \bar{\mathbf{E}} = -\mu \left[ \frac{\partial}{\partial t} \left( \bar{\mathbf{J}} + \frac{\partial \bar{\mathbf{D}}}{\partial t} \right) \right]$$

Making both sides positive,

$$\nabla^2 \bar{\mathbf{E}} = \mu \left[ \frac{\partial}{\partial t} \left( \bar{\mathbf{J}} + \frac{\partial \bar{\mathbf{D}}}{\partial t} \right) \right] \quad \dots (5)$$

Consider a general electromagnetic wave with both the fields,  $\bar{\mathbf{E}}$  and  $\bar{\mathbf{H}}$  varying with respect to time. When any field varies with respect to time, its partial derivative taken with respect to time can be replaced by  $j\omega$ . Rewriting equation (5) in phasor form,

$$\therefore \nabla^2 \bar{\mathbf{E}} = \mu [j\omega (\bar{\mathbf{J}} + j\omega \bar{\mathbf{D}})]$$

$$\therefore \nabla^2 \bar{\mathbf{E}} = j\omega \mu [(\sigma \bar{\mathbf{E}}) + j\omega (\epsilon \bar{\mathbf{E}})]$$

$$\therefore \nabla^2 \bar{\mathbf{E}} = [j\omega \sigma \mu \bar{\mathbf{E}} + (j\omega)^2 \epsilon \mu \bar{\mathbf{E}}]$$

$$\therefore \nabla^2 \bar{\mathbf{E}} = [j\omega \mu (\sigma + j\omega \epsilon)] \bar{\mathbf{E}} \quad \dots (6)$$

In similar way, we can write another phasor equation as,

$$\nabla^2 \bar{\mathbf{H}} = [j\omega\mu(\sigma + j\omega\epsilon)]\bar{\mathbf{H}} \quad \dots (7)$$

The terms inside the bracket in equations (6) and (7) are exactly similar and represent the properties of the medium in which **wave** is propagating. The total bracket is the square of a propagation constant  $\gamma$ , hence we can rewrite equations (6) and (7) as,

$$\begin{aligned} \nabla^2 \bar{\mathbf{E}} &= \gamma^2 \bar{\mathbf{E}} \quad \text{and} \\ \nabla^2 \bar{\mathbf{H}} &= \gamma^2 \bar{\mathbf{H}} \end{aligned}$$

So the propagation constant  $\gamma$  can be expressed in terms of properties of the medium as,

$$\gamma = \alpha + j\beta = \sqrt{j\omega\mu(\sigma + j\omega\epsilon)} \quad \dots (8)$$

The real and imaginary parts of  $\gamma$  are attenuation constant ( $\alpha$ ) and phase constant ( $\beta$ ) and both can be expressed in terms of the properties of the medium,

$$\therefore \alpha = \omega \sqrt{\frac{\mu\epsilon}{2} \left( \sqrt{1 + \left(\frac{\sigma}{\omega\epsilon}\right)^2} - 1 \right)} \quad \dots (9)$$

$$\text{and } \beta = \omega \sqrt{\frac{\mu\epsilon}{2} \left( \sqrt{1 + \left(\frac{\sigma}{\omega\epsilon}\right)^2} + 1 \right)} \quad \dots (10)$$

The intrinsic impedance of a medium can be expressed in terms of the properties of a medium and is given by,

$$\eta = \sqrt{\frac{j\omega\mu}{\sigma + j\omega\epsilon}} \quad \dots (11)$$

It can also be expressed in polar form as  $|\eta| \angle \theta$  where

$$\begin{aligned} |\eta| &= \frac{\sqrt{\mu/\epsilon}}{\sqrt{1 + \left(\frac{\sigma}{\omega\epsilon}\right)^2}} \quad \text{and} \\ \tan 2\theta &= \frac{\sigma}{\omega\epsilon} \quad 0^\circ < \theta < 45^\circ \end{aligned}$$

Let us summarize the equations which are helpful in describing the electromagnetic waves (**uniform plane waves**). Table 9.1 lists equations describing the propagation of EM waves in a medium.

### 9.4 Uniform Plane Wave in Perfect Dielectric

If a medium, through which the **uniform plane wave** is propagating, is perfect dielectric (which is also called lossless dielectric), then the conductivity is zero i.e.  $\sigma = 0$ . Let the permittivity permeability of the medium be  $\epsilon = \epsilon_0 \epsilon_r$  and  $\mu = \mu_0 \mu_r$  respectively.

The propagation constant  $\gamma$  is given by,

$$\gamma = \sqrt{j\omega\mu(0 + j\omega\epsilon)} = \pm j\omega\sqrt{\mu\epsilon}$$

$$\therefore \boxed{\gamma = \alpha + j\beta = \pm j\omega\sqrt{\mu\epsilon}} \quad \dots (1)$$

From equation (1) it is clear that, propagation constant is purely imaginary. It indicates in a perfect dielectric medium, attenuation constant  $\alpha$  is zero. Let us select value of  $\beta$  which gives propagation of **wave** in positive z-direction.

$$\therefore \alpha = 0, \quad \beta = \omega\sqrt{\mu\epsilon} \quad \dots (2)$$

Similarly an intrinsic impedance for a perfect dielectric medium is given by,

$$\boxed{\eta = \sqrt{\frac{j\omega\mu}{0 + j\omega\epsilon}} = \sqrt{\frac{\mu}{\epsilon}} \Omega} \quad \dots (3)$$

Thus intrinsic impedance  $\eta$  is real resistive. That means phase angle of intrinsic impedance is zero. But the phase angle of intrinsic impedance is zero means phase difference between  $\bar{E}$  and  $\bar{H}$  is zero. In other words, for a perfect dielectric, both the fields  $\bar{E}$  and  $\bar{H}$ , are in phase.

As in perfect dielectric,  $\sigma = 0$ , attenuation constant ( $\alpha$ ) is also zero. As **wave** propagates, only the phase ( $\beta$ ) changes. Thus no attenuation i.e.  $\alpha = 0$  means no loss.

**Key Point:** So perfect dielectric medium is also called **lossless dielectric**.

The velocity of propagation in the perfect dielectric is given by,

$$v = \frac{1}{\sqrt{\mu\epsilon}} = \frac{\omega}{\beta} \quad \dots (4)$$

If  $\lambda$  is the wavelength of one cycle of the propagating **wave** then velocity is given by

$$v = \lambda f \text{ m/s} \quad \dots (5)$$

### 9.5 Uniform Plane Wave in Lossy Dielectric

Practically all the dielectric materials exhibit some conductivity. So we can not directly neglect  $\sigma$  assuming it zero. Obviously as compared to the results obtained for perfect dielectric medium, the results for lossy dielectric will be different.

The propagation constant  $\gamma$  in lossy dielectric is given by

$$\gamma = \pm \sqrt{(\sigma + j\omega\epsilon)j\omega\mu} \quad \dots (1)$$

Rearranging the terms

$$\gamma = \sqrt{j\omega\epsilon \left(1 + \frac{\sigma}{j\omega\epsilon}\right)j\omega\mu}$$

$$\therefore \gamma = \alpha + j\beta = j\omega\sqrt{\mu\epsilon} \sqrt{1 - j\frac{\sigma}{\omega\epsilon}} \quad \dots (2)$$

From equation (2), it is clear that the propagation constant for lossy dielectric medium is different than that for lossless dielectric medium, due to the presence of radical factor. When  $\sigma$  becomes zero as in case with perfect dielectric, the radical factor becomes unity and we can obtain the propagation constant  $\gamma$  for perfect dielectric. It is also clear from equation (2) that the attenuation constant  $\alpha$  is not zero. By substituting the values of  $\omega, \sigma, \mu$  and  $\epsilon$ , the attenuation constant ( $\alpha$ ) and phase constant  $\beta$  may be calculated. The presence of  $\alpha$  indicates certain loss of signal in the medium, hence such medium is called **lossy dielectric**.

When a **wave** propagates in a lossy dielectric, amplitude of the signal decays exponentially due to the factor  $e^{-\alpha z}$ . For forward as well as backward waves, the amplitude decays exponentially.

As  $\sigma$  is not zero, the intrinsic impedance becomes a complex quantity. It is given by,

$$\eta = \sqrt{\frac{j\omega\mu}{\sigma + j\omega\epsilon}} = |\eta| \angle \theta_n \Omega \quad \dots (3)$$

Being a complex quantity,  $\eta$  is represented in polar form as shown in above equation. This angle  $\theta_n$  indicates phase difference between the electric and magnetic fields. Thus in **lossy dielectric, the electric and magnetic fields are not in time phase**.

The intrinsic impedance can be expressed as

$$\eta = \sqrt{\frac{j\omega\mu}{\sigma + j\omega\epsilon}} = \sqrt{\frac{j\omega\mu}{j\omega\epsilon \left(1 + \frac{\sigma}{j\omega\epsilon}\right)}}$$



$$\therefore \eta = \sqrt{\frac{\mu}{\epsilon}} \frac{1}{\sqrt{1 - j \frac{\sigma}{\omega \epsilon}}} \Omega \quad \dots (4)$$

The angle  $\theta_n$  is given by

$$\theta_n = \frac{1}{2} \left[ \frac{\pi}{2} - \tan^{-1} \left( \frac{\omega \epsilon}{\sigma} \right) \right] \text{ rad} \quad \dots (5)$$

This angle depends on the properties of the lossy dielectric medium as well as the frequency of a signal. For low frequency signal,  $\omega$  becomes very small. Then

$$\theta_n \approx \frac{\pi}{4} \text{ rad}$$

For very high frequency signals,

$$\theta_n \approx 0$$

Thus the range of  $\theta_n$  for complete frequency range, from 0 to very high frequency is  $0 < \theta_n < \frac{\pi}{4}$ .

### 9.5.1 Uniform Plane Wave in Practical Dielectric

As we have already studied, for perfect dielectric conductivity is zero ( $\sigma = 0$ ). But for practical dielectric, conductivity is not zero ; but it is very small. The condition for practical dielectric is that the loss in the signal is very small i.e.  $\sigma \ll j\omega\epsilon$ .

The propagation constant is given by

$$\gamma = \sqrt{j\omega\mu(\sigma + j\omega\epsilon)}$$

$$\therefore \gamma = \sqrt{(j\omega\mu)(j\omega\epsilon) \left( 1 + \frac{\sigma}{j\omega\epsilon} \right)}$$

$$\therefore \gamma = j\omega\sqrt{\mu\epsilon} \sqrt{1 + \frac{\sigma}{j\omega\epsilon}}$$

Consider radical term. Mathematically using binomial theorem,

$$(1+x)^n = 1 + nx + \frac{n(n-1)}{2!} x^2 + \frac{n(n-1)(n-2)}{3!} x^3 + \dots$$

where  $|x| < 1$ .

In our case  $|x| < 1$  and  $n = \frac{1}{2}$ , then neglecting higher order terms, we can write,

$$\left(1 + \frac{\sigma}{j\omega\epsilon}\right)^{\frac{1}{2}} = 1 + \frac{1}{2} \left(\frac{\sigma}{j\omega\epsilon}\right)$$

Substituting above value for the radical term,

$$\gamma = j\omega\sqrt{\mu\epsilon} \left[1 + \frac{\sigma}{j2\omega\epsilon}\right]$$

$$\therefore \gamma = \alpha + j\beta = \frac{\sigma}{2} \sqrt{\frac{\mu}{\epsilon}} + j\omega\sqrt{\mu\epsilon} \quad \dots (1)$$

Comparing the real terms, the attenuation constant is given by

$$\alpha = \frac{\sigma}{2} \sqrt{\frac{\mu}{\epsilon}} \text{ Np / m} \quad \dots (2)$$

Similarly comparing the imaginary terms, the phase constant is given by

$$\beta = \omega\sqrt{\mu\epsilon} \text{ rad/m} \quad \dots (3)$$

In general, the intrinsic impedance  $\eta$  is given by,

$$\eta = \sqrt{\frac{j\omega\mu}{\sigma + j\omega\epsilon}} = \sqrt{\frac{j\omega\mu}{j\omega\epsilon \left(1 + \frac{\sigma}{j\omega\epsilon}\right)}}$$

$$\therefore \eta = \sqrt{\frac{\mu}{\epsilon}} \sqrt{\frac{1}{1 + \frac{\sigma}{j\omega\epsilon}}}$$

$$\therefore \eta = \sqrt{\frac{\mu}{\epsilon}} \left[1 + \frac{\sigma}{j\omega\epsilon}\right]^{-\frac{1}{2}}$$

Using binomial theorem,

$$(1+x)^{-n} = 1 - nx + \frac{n(n-1)}{2!} x^2 - \frac{n(n-1)(n-2)}{3!} x^3 \dots$$

As  $x = \frac{\sigma}{j\omega\epsilon}$  is very small as compared to 1, so neglecting higher order terms,

$$(1+x)^{-n} = 1 - nx$$

Using above result, the intrinsic impedance can be written as,

$$\eta = \sqrt{\frac{\mu}{\epsilon}} \left[ 1 - \frac{1}{2} \left( \frac{\sigma}{j\omega\epsilon} \right) \right]$$

$$\therefore \boxed{\eta = \sqrt{\frac{\mu}{\epsilon}} \left( 1 + j \frac{\sigma}{\omega\epsilon} \right) \Omega} \quad \dots (4)$$

For practical dielectric material, the conductivity is very small. This indicates that the loss in the signal is very small. Let us obtain the condition which indicates whether the loss is small or not. Consider Maxwell's equation,

$$\nabla \times \bar{H} = \bar{J}_C + \frac{\partial \bar{D}}{\partial t} = \partial \bar{E} + \frac{\partial (\epsilon \bar{E})}{\partial t}$$

We know that when the fields are time varying the partial derivative with respect to time can be replaced by  $j\omega$ .

$$\therefore \nabla \times \bar{H} = \sigma \bar{E} + j\omega\epsilon \bar{E} = (\sigma + j\omega\epsilon) \bar{E}$$

$$\text{or} \quad \nabla \times \bar{H} = \bar{J}_C + \bar{J}_D$$

Thus the ratio of the conduction current density to the displacement current density is given by

$$\frac{\bar{J}_C}{\bar{J}_D} = \frac{\sigma}{j\omega\epsilon}$$

These two current density vectors point in same direction in space as shown in the Fig. 9.1. From the expression of ratio of two current densities, it is clear that displacement current density leads conduction current density by  $90^\circ$ .

The angle  $\theta$  by which the displacement current density leads the total current density is given by

$$\theta = \tan^{-1} \frac{\sigma}{\omega\epsilon}$$

$$\text{or} \quad \boxed{\tan \theta = \frac{\sigma}{\omega\epsilon}}$$

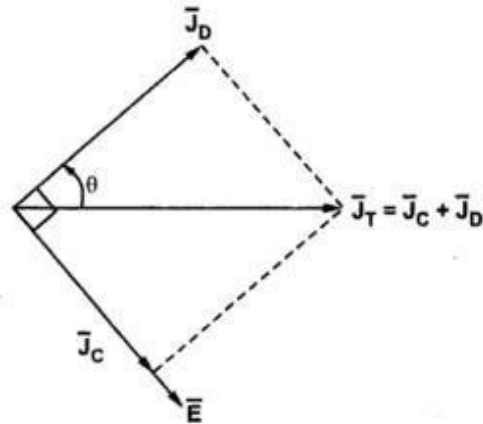


Fig. 9.1 Phasor representation of  $\bar{J}_C$ ,  $\bar{J}_D$  and  $\bar{E}$

When  $\sigma \gg \omega\epsilon$ , the loss tangent is very high, thus a medium is said to be good conductor. When  $\sigma \ll \omega\epsilon$ , the loss tangent is also small, thus a medium is said to be good dielectric. Hence any medium behaves as a good conductor at low frequencies while exhibits the properties of lossy dielectric at very high frequencies.

### 9.6 Uniform Plane Wave in Good Conductor

A practical or good conductor is the material which has very high conductivity. In general, the conductivity is of the order of  $10^7$  U/m in the good conductors like copper, aluminium etc.

For good conductors,

$$\frac{\sigma}{\omega\epsilon} \gg 1$$

The propagation constant  $\gamma$  is given by,

$$\gamma = \sqrt{j\omega\mu(\sigma + j\omega\epsilon)} \quad \dots (1)$$

As  $\sigma \gg \omega\epsilon$ , we can neglect imaginary part ( $j\omega\epsilon$ ),

$$\therefore \gamma = \sqrt{j\omega\mu\sigma}$$

$$\therefore \gamma = \sqrt{\omega\mu\sigma} \sqrt{j}$$

But  $j = 1 \angle 90^\circ$

$$\therefore \gamma = \sqrt{\omega\mu\sigma} \sqrt{1 \angle 90^\circ}$$

$$\therefore \gamma = \sqrt{\omega\mu\sigma} \angle 45^\circ$$

$$\therefore \gamma = \sqrt{\omega\mu\sigma} [\cos 45^\circ + j \sin 45^\circ]$$

$$\therefore \gamma = \sqrt{\omega\mu\sigma} \left[ \frac{1}{\sqrt{2}} + j \frac{1}{\sqrt{2}} \right]$$

$$\therefore \gamma = \sqrt{(2\pi f)\mu\sigma} \left[ \frac{1}{\sqrt{2}} (1 + j) \right]$$

$$\therefore \gamma = \alpha + j\beta = \sqrt{\pi f\mu\sigma} + j \sqrt{\pi f\mu\sigma} \quad \dots (2)$$

Thus for good conductor,

$$\alpha = \sqrt{\pi f\mu\sigma} \text{ Np/m and}$$

$$\beta = \sqrt{\pi f\mu\sigma} \text{ rad/m}$$

For good conductor,  $\alpha$  and  $\beta$  are equal and both are directly proportional to the square root of frequency ( $f$ ) and conductivity ( $\sigma$ ).

The intrinsic impedance of a good conductor is given by

$$\eta = \sqrt{\frac{j\omega\mu}{\sigma + j\omega\epsilon}} \quad \dots (3)$$

But for good conductor,  $\sigma \gg j\omega\epsilon$ ,

$$\therefore \eta = \sqrt{\frac{j\omega\mu}{\sigma}} = \sqrt{\frac{\omega\mu}{\sigma}} \sqrt{j}$$

But  $\sqrt{j} = \sqrt{1 \angle 90^\circ} = 1 \angle 45^\circ = \cos 45^\circ + j \sin 45^\circ$

$$\therefore \sqrt{j} = \left( \frac{1}{\sqrt{2}} + j \frac{1}{\sqrt{2}} \right)$$

Substituting value of  $\sqrt{j}$ ,

$$\eta = \sqrt{\frac{\omega\mu}{\sigma}} \left[ \frac{1}{\sqrt{2}} + j \frac{1}{\sqrt{2}} \right]$$

$$\therefore \eta = \sqrt{\frac{\omega\mu}{2\sigma}} (1 + j 1)$$

$$\therefore \eta = \sqrt{\frac{2\pi f\mu}{2\sigma}} (1 + j 1)$$

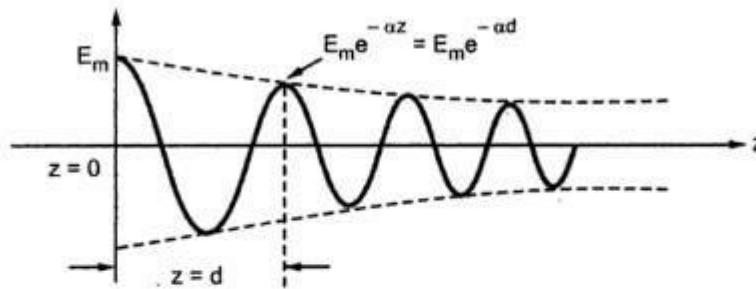
$$\therefore \eta = \sqrt{\frac{\pi f\mu}{\sigma}} (1 + j 1) \quad \dots (4)$$

The angle of intrinsic impedance is  $45^\circ$ . As we have already studied that for perfect dielectric i.e. zero conductivity, the intrinsic impedance angle is zero and for the good conductor angle is  $45^\circ$ . Moreover the intrinsic impedance has only a positive angle. This clearly indicates that the field  $\vec{H}$  may lag the field  $\vec{E}$  by at the most  $45^\circ$ .

Consider only the component of the electric field  $E_x$  travelling in positive  $z$ -direction. When it travels in good conductor, the conductivity is very high and attenuation constant  $\alpha$  is also high. Thus we can write such a component in phasor form as

$$E_x = E_m^+ e^{-\alpha z} e^{-j\beta z} \quad \dots (5)$$

When such a **wave** propagates in good conductor, there is a large attenuation of the amplitude as shown in the Fig. 9.2.

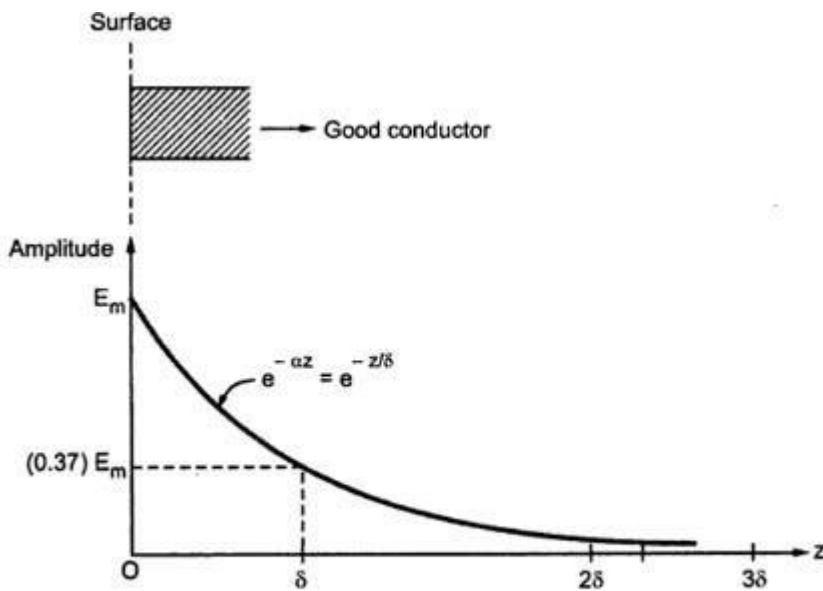


**Fig. 9.2 Effect of attenuation constant ( $\alpha$ ) on amplitude of  $E_x$**

At  $z = 0$ , amplitude of the component  $E_x$  is  $E_m$  ; while at  $z = d$ , amplitude is  $E_m e^{-\alpha d}$ . In distance  $z = d$ , the amplitude gets reduced by the factor  $e^{-\alpha d}$ . If we select  $d = \frac{1}{\alpha}$ , then the factor becomes  $e^{-1} = 0.368$ . So over a distance  $d = \frac{1}{\alpha}$  the amplitude of the **wave** decreases to approximately 37% of its original value. The distance through which the amplitude of the travelling **wave** decreases to 37% of the original amplitude is called **skin depth** or **depth of penetration**. It is denoted by  $\delta$ .

$$\therefore \text{Skin depth} = \delta = \frac{1}{\alpha} = \frac{1}{\beta} = \frac{1}{\sqrt{\pi f \mu \sigma}} \text{ m} \quad \dots (6)$$

**From** the expression of the skin depth, it is clear that  $\delta$  is inversely proportional to the square root of frequency. So for the frequencies in the microwave range, the skin depth or depth of penetration is very small for good conductors. And all the fields and currents may be considered as confined to a very thin layer near the surface of the conductor. This thin layer is nothing but the skin of the conductor, hence this effect is called **skin effect**. The exponential decay in the amplitude of  $\vec{E}$  or  $\vec{H}$  field component entering in a good conductor is as shown in the Fig. 9.3.



**Fig. 9.3 Exponential decay in the amplitude of field component of  $\vec{E}$  with the distance along  $+z$  direction**

From above plot, it is clear that in  $1\delta$  distance, amplitude reduces to 37% of its original value. For a good conductor, amplitude reduces to almost zero within  $2\delta$  or  $3\delta$  distance. Thus **uniform plane wave** can not travel large distance through good conductor. This concept is used in a shielding of a conductor. In a co-axial cable, the inner conductor carries the signal while the outer is shield which is made up of a material having properties of good conductor. So even if there is an external interference, its amplitude reduces to zero within a very short distance due to the outer conductor. Hence the signal carried by inner conductor is not interfered by an external interference.

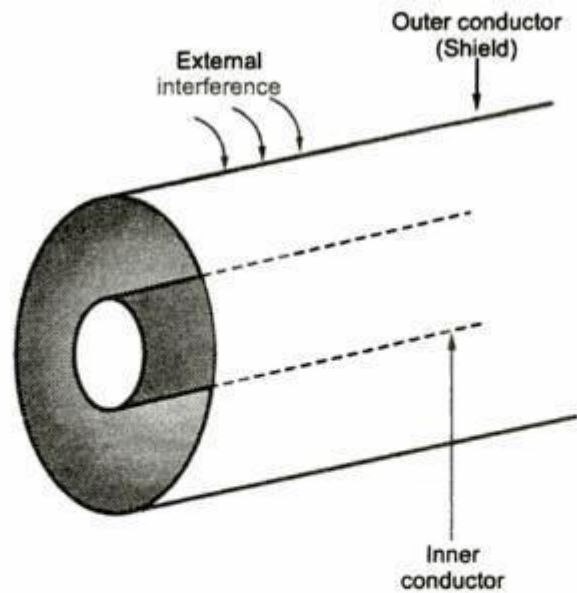


Fig. 9.4 Shielding of a co-axial cable

The intrinsic impedance of a good conductor in terms of skin depth  $\delta$  is given by,

$$\eta = \left( \frac{1}{\sigma\delta} + j \frac{1}{\sigma\delta} \right) = \frac{\sqrt{2}}{\sigma\delta} \angle 45^\circ \Omega \quad \dots (7)$$

The velocity of propagation is given by,

$$v = \frac{\omega}{\beta} = \frac{\omega}{\sqrt{\pi f \mu \sigma}} = \frac{\sqrt{2} (\sqrt{\omega})^2}{\sqrt{2} \sqrt{\pi f \mu \sigma}} = \frac{\sqrt{2} (\sqrt{\omega})^2}{\sqrt{\omega \mu \sigma}}$$

$$\therefore v = \sqrt{\frac{2\omega}{\mu \sigma}} = \omega \delta \text{ m/s} \quad \dots (8)$$

Similarly the wavelength  $\lambda$  is given by,

$$\lambda = \frac{2\pi}{\beta} = 2\pi\delta \text{ m} \quad \dots (9)$$

Equations (8) and (9) give the velocity of propagation and wavelength expressed in terms of skin depth  $\delta$  (as  $\beta = \frac{1}{\delta}$ ).

### 8.9 Poynting Vector and Poynting Theorem

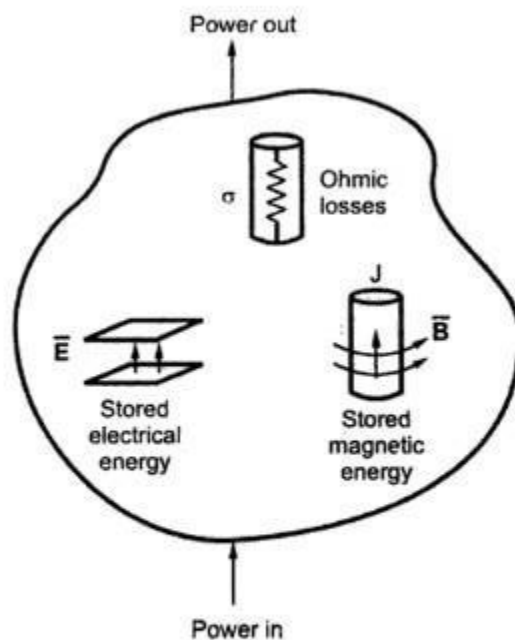
By the means of electromagnetic (EM) waves, an energy can be transported from transmitter to receiver. The energy stored in an electric field and magnetic field is transmitted at a certain rate of energy flow which can be calculated with the help of **Poynting theorem**. As we know  $\vec{E}$  and  $\vec{H}$  are basic fields.  $\vec{E}$  is electric field expressed in V/m; while  $\vec{H}$  is magnetic field measured in A/m. So if we take product of two



fields, dimensionally we get a unit  $V.A/m^2$  or  $watt/m^2$ . So this product of  $\vec{E}$  and  $\vec{H}$  gives a new quantity which is expressed as watt per unit area. Thus this quantity is called **power density**.

As  $\vec{E}$  and  $\vec{H}$  both are vectors, to get power density we may carry out either dot product or cross product. The result of a dot product is always a scalar quantity. But as power flows in certain direction, it is a vector quantity. To illustrate this, consider that the field is transmitted in the form of an electromagnetic waves from an antenna. Both the fields are sinusoidal in nature. **The power radiated from antenna has a particular direction.** Hence to calculate a power density, we must carry out a **cross product** of  $\vec{E}$  and  $\vec{H}$ . The power density is given by

$$\vec{P} = \vec{E} \times \vec{H} \quad \dots(1)$$



**Fig. 8.4 Power balance representation in electromagnetic fields**

where  $\vec{P}$  is called **Poynting Vector**, named after an English Physicist John N. **Poynting**.  $\vec{P}$  is the instantaneous power density vector associated with the electromagnetic (EM) field at a given point. The direction of  $\vec{P}$  indicates instantaneous power flow at the point. To get a net power flowing out of any surface,  $\vec{P}$  is integrated over same closed surface.

The **Poynting theorem** is based on law of conservation of energy in electromagnetism. **Poynting theorem** can be stated as follows :

The net power flowing out of a given volume  $v$  is equal to the time rate of decrease in the energy stored within volume  $v$  minus the ohmic power dissipated. This can be well illustrated by the Fig. 8.4.

Suppose  $\vec{E} = E_x \vec{a}_x$   
 and  $\vec{H} = H_y \vec{a}_y$ , then  

$$\vec{P} = \vec{E} \times \vec{H}$$

$$= (E_x \vec{a}_x) \times (H_y \vec{a}_y) = E_x H_y \vec{a}_z = P_z \vec{a}_z$$

The above equation indicates that  $\bar{E}$ ,  $\bar{H}$  and  $\bar{P}$  are mutually perpendicular to each other.

Consider that the electric field propagates in free space given by

$$\bar{E} = [E_m \cos(\omega t - \beta z)] \bar{a}_x$$

In the medium, the ratio of magnitudes of  $\bar{E}$  and  $\bar{H}$  depends on its intrinsic impedance  $\eta$ . For free space,

$$\eta = \eta_0 = \frac{E_m}{H_m} = 120\pi = 377\Omega$$

Moreover, in the free space, electromagnetic wave travels at a speed of light.

Thus we can write,

$$\bar{H} = [E_m \cos(\omega t - \beta z)] \bar{a}_y$$

$$\therefore \bar{H} = \left[ \frac{E_m}{\eta_0} \cos(\omega t - \beta z) \right] \bar{a}_y$$

According to **Poynting theorem**

$$\begin{aligned} \bar{P} &= \bar{E} \times \bar{H} \\ &= [(E_m \cos(\omega t - \beta z)) \bar{a}_x] \times \left[ \frac{E_m}{\eta_0} \cos(\omega t - \beta z) \bar{a}_y \right] \end{aligned}$$

$$\therefore \bar{P} = \frac{E_m^2}{\eta_0} \cos^2(\omega t - \beta z) \bar{a}_z \text{ W / m}^2$$

This is nothing but the power density measured in watt/m<sup>2</sup>. Thus the power passing particular area is given by,

$$\text{Power} = \text{Power density} \times \text{Area}$$

### 8.9.1 Average Power Density ( $P_{avg}$ )

To find average power density, let us integrate power density in z-direction over one cycle and divide by the period T of one cycle.

$$\begin{aligned} \therefore P_{avg} &= \frac{1}{T} \int_0^T \frac{E_m^2}{\eta} \cos^2(\omega t - \beta z) dt \\ &= \frac{E_m^2}{T\eta} \int_0^T \frac{1 + \cos 2(\omega t - \beta z)}{2} dt \end{aligned}$$

$$\begin{aligned}
 &= \frac{E_m^2}{T\eta} \left[ \frac{t}{2} + \frac{\sin 2(\omega t - \beta z)}{2(2\omega)} \right]_0^T \\
 &= \frac{E_m^2}{T\eta} \left[ \frac{t}{2} + \frac{\sin 2(\omega t - \beta z)}{4\omega} \right]_0^T \\
 &= \frac{E_m^2}{T\eta} \left[ \frac{t}{2} + \frac{\sin (2\omega t - 2\beta z)}{4\omega} \right]_0^T \\
 &= \frac{E_m^2}{T\eta} \left[ \frac{T}{2} + \frac{\sin (2\omega T - 2\beta z)}{4\omega} - \frac{\sin (-2\beta z)}{4\omega} \right]
 \end{aligned}$$

But  $\omega T = 2\pi$

$$\begin{aligned}
 \therefore P_{avg} &= \frac{E_m^2}{T\eta} \left[ \frac{T}{2} + \frac{\sin (4\pi - 2\beta z)}{4\omega} + \frac{\sin 2\beta z}{4\omega} \right] \\
 &= \frac{E_m^2}{T\eta} \left[ \frac{T}{2} - \frac{\sin 2\beta z}{4\omega} + \frac{\sin 2\beta z}{4\omega} \right] = \frac{E_m^2}{2\eta}
 \end{aligned}$$

Hence the average power is given by

$$P_{avg} = \frac{1}{2} \frac{E_m^2}{\eta} \text{ W / m}^2$$

## 8.10 Integral and Point Forms of Poynting Theorem

Consider Maxwell's equations as given below :

$$\nabla \times \vec{E} = -\frac{\partial \vec{B}}{\partial t} = -\mu \frac{\partial \vec{H}}{\partial t} \quad \dots (1)$$

$$\nabla \times \vec{H} = \vec{J} + \frac{\partial \vec{D}}{\partial t} = \sigma \vec{E} + \epsilon \frac{\partial \vec{E}}{\partial t} \quad \dots (2)$$

Dotting both the sides of equation (3) with  $\vec{E}$ , we get,

$$\vec{E} \cdot (\nabla \times \vec{H}) = \vec{E} \cdot (\sigma \vec{E}) + \vec{E} \cdot \left( \epsilon \frac{\partial \vec{E}}{\partial t} \right) \quad \dots (3)$$

Let us make use of a vector identity as given below,

$$\nabla \cdot (\vec{A} \times \vec{B}) = \vec{B} \cdot (\nabla \times \vec{A}) - \vec{A} \cdot (\nabla \times \vec{B})$$

Applying above vector identity to equation (4) with  $\bar{A} = \bar{E}$  and  $\bar{B} = \bar{H}$ ,

$$\bar{H} \cdot (\nabla \times \bar{E}) - \nabla \cdot (\bar{E} \times \bar{H}) = \bar{E} \cdot (\sigma \bar{E}) + \bar{E} \cdot \left( \epsilon \frac{\partial \bar{E}}{\partial t} \right)$$

$$\therefore \bar{H} \cdot (\nabla \times \bar{E}) - \nabla \cdot (\bar{E} \times \bar{H}) = \sigma E^2 + \bar{E} \cdot \left( \epsilon \frac{\partial \bar{E}}{\partial t} \right) \quad \dots (4)$$

Consider first term on left of equation (5). Putting value of  $\nabla \times \bar{E}$  from equation (1) we can write,

$$\bar{H} \cdot (\nabla \times \bar{E}) = \bar{H} \cdot \left( -\mu \frac{\partial \bar{H}}{\partial t} \right) = -\mu \bar{H} \cdot \frac{\partial \bar{H}}{\partial t} \quad \dots (i)$$

Now consider term,

$$\frac{\partial}{\partial t} (\bar{H} \cdot \bar{H}) = \bar{H} \cdot \frac{\partial \bar{H}}{\partial t} + \bar{H} \cdot \frac{\partial \bar{H}}{\partial t}$$

$$\therefore \frac{\partial}{\partial t} H^2 = 2 \bar{H} \cdot \frac{\partial \bar{H}}{\partial t}$$

$$\therefore \frac{1}{2} \frac{\partial}{\partial t} (H^2) = \bar{H} \cdot \frac{\partial \bar{H}}{\partial t} \quad \dots (ii)$$

Similarly we can write,

$$\frac{1}{2} \frac{\partial}{\partial t} (E^2) = \bar{E} \cdot \frac{\partial \bar{E}}{\partial t} \quad \dots (iii)$$

Using results obtained in equations (i), (ii) and (iii) in equation (4),

$$-\frac{\mu}{2} \frac{\partial}{\partial t} (H^2) - \nabla \cdot (\bar{E} \times \bar{H}) = \sigma E^2 + \frac{\epsilon}{2} \frac{\partial}{\partial t} (E^2)$$

$$\therefore -\nabla \cdot (\bar{E} \times \bar{H}) = \sigma E^2 + \frac{1}{2} \frac{\partial}{\partial t} [\mu H^2 + \epsilon E^2]$$

But  $\bar{E} \times \bar{H}$  is nothing but **Poynting** vector;  $\bar{P}$ , rewriting equation,

$$\therefore \boxed{-\nabla \cdot \bar{P} = \sigma E^2 + \frac{1}{2} \frac{\partial}{\partial t} [\mu H^2 + \epsilon E^2]} \quad \dots (5)$$

Equation (5) represents **Poynting theorem** in point form. If we integrate this power over a volume, we get energy distribution as,

$$-\int_v \nabla \cdot \bar{P} dv = \int_v \sigma E^2 dv + \frac{\partial}{\partial t} \int_v \frac{1}{2} [\mu H^2 + \epsilon E^2] dv$$

Applying divergence **theorem** to left of above equation, we get,

$$-\oint_S \bar{\mathbf{P}} \cdot d\bar{\mathbf{S}} = \int_v \sigma E^2 dv + \frac{\partial}{\partial t} \int_v \frac{1}{2} [\mu H^2 + \epsilon E^2] dv \quad \dots(6)$$

Equation (6) represents **Poynting theorem in integral form**. The negative sign on the left of equation (6) indicates that the power is flowing into the surface. The first term on the right gives the total ohmic power loss within the volume, while the second term represents time rate of increase of total energy stored in the electric and magnetic fields. By the law of conservation of energy, the sum of the two terms on right must be equal to the total power flowing into the volume. Thus the **minus sign indicates the power flowing into the volume**. So the total power flowing out of the volume is given by  $\oint_S \bar{\mathbf{P}} \cdot d\bar{\mathbf{S}}$ . This can be represented with the help of equation as

given below,

$$\oint_S \bar{\mathbf{P}} \cdot d\bar{\mathbf{S}} = -\int_v \sigma E^2 dv - \frac{\partial}{\partial t} \int_v \frac{1}{2} [\mu H^2 + \epsilon E^2] dv \quad \dots (7)$$

When we define **Poynting** vector, both the fields  $\bar{\mathbf{E}}$  and  $\bar{\mathbf{H}}$  are assumed to be in the real form. If  $\bar{\mathbf{E}}$  and  $\bar{\mathbf{H}}$  are expressed in phasor form, then the average power is given by,

$$\bar{P}_{avg} = \frac{1}{2} \text{Re}[\bar{\mathbf{E}} \times \bar{\mathbf{H}}^*] = \frac{1}{2} \text{Re}[\bar{\mathbf{E}}^* \times \bar{\mathbf{H}}] \quad \dots(8)$$

where  $\bar{\mathbf{H}}^*$  is the complex conjugate of  $\bar{\mathbf{H}}$  and  $\bar{\mathbf{E}}^*$  is the complex conjugate of  $\bar{\mathbf{E}}$ .